



Service information

Reference no.: SDA_78805

Symptom

Mains switch does not operate

Cure

INFO:

From market returns it became clear that the mains switch gets damaged using too much force on the on/off button!

Cure:

Appliances are from now on equipped with a protective ring (see attached image). If this ring is missing it must still be placed as modification.
Sparepart code 4222 459

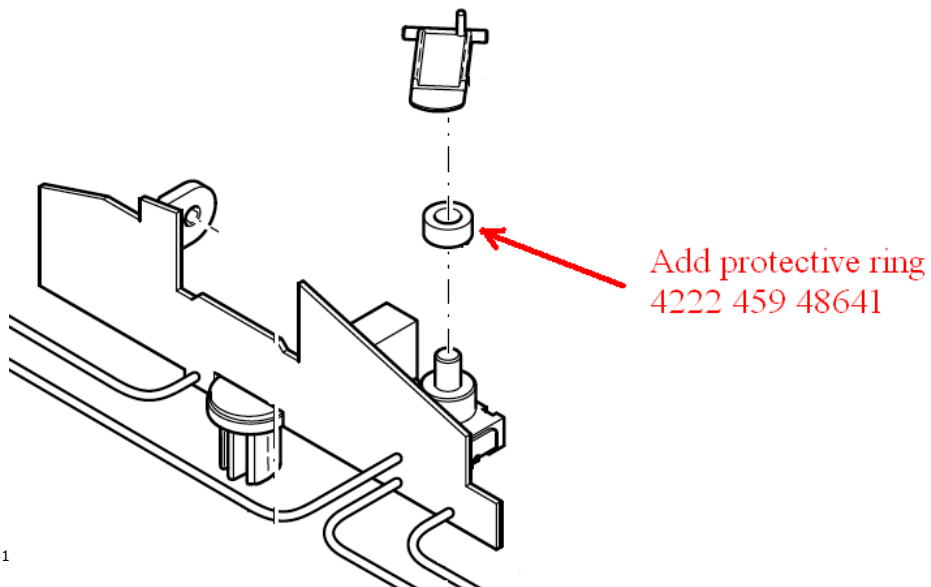

48641