

# PRIMEA LINE



# TECHNICAL SERVICE MANUAL

All parts of this document are property of **Saeco International Group**. All rights reserved.  
This document and relative information herein are provided without liability deriving from any errors or omissions. Furthermore, no part may be reproduced, used or collected with the exception of that authorised in writing or in accordance with a contractual clause.

**PRIMEA TECHNICAL SERVICE MANUAL (Rev.01 Aug 06)**

- 1. Introduction (rev.00)**
  - 1.1 Documentation required
  - 1.2 Tools and equipment required
  - 1.3 Safety warnings
- 2. Technical data (rev.00)**
  - 2.1 Product technical data
  - 2.2 Internal / external machine components
- 3. Summarised instructions (rev.01)**
  - 3.1 Client and programming menu (rev.00)
  - 3.2** Maintenance and cleaning (rev.01)
- 4. Diagrams (rev.00)**
  - 4.1 Wiring diagram (rev.00)
  - 4.2 Component load table (rev.00)
  - 4.3 Water circuit diagram (rev.00)
- 5. Troubleshooting (rev.01)**
  - 5.1 Primea Touch and Touch Plus test functions (rev.01)
  - 5.2 Primea Touch e Touch Plus diagnosis function (rev.01)
  - 5.3 Primea Ring test functions (rev.01)
  - 5.4 Primea Ring diagnosis function (rev.01)
  - 5.5 Error messages for Service personnel (rev.01)
  - 6.5 Problem, Cause, Remedies (rev.01)
- 6. Operating logic (rev.01)**
  - 6.1** Multi-way valve (rev.01)
  - 6.2 Auto cappuccino facility (rev.00)
  - 6.3 Motorized tank (rev.00)
  - 6.4 Prima water (rev.00)
  - 6.5 SBS valve (rev.00)
- 7. Component assembly / disassembly (rev.01)**
  - 7.1 Top cover (rev.00)
  - 7.2 Right side cover (rev.00)
  - 7.3 Left side cover (rev.00)
  - 7.4 Coffee dispenser (rev.00)
  - 7.5 Electronics (rev.00)
  - 7.6 Gearmotor (rev.00)
  - 7.7 Pump (rev.00)
  - 7.8 Boiler and multi-way valve assembly (rev.00)
  - 7.9 Boiler (rev.00)
  - 7.10** Multi-way valve (rev.01)
  - 7.11 Oetiker clamp assembly and disassembly (rev.00)
  - 7.12 Coffee grinder (rev.00)
  - 7.13 Grinder adjustment/disassembly and assembly
  - 7.14 Strength adjustment (rev.00)
  - 7.15** Autocappuccino (rev.01)
  - 7.16 Motorized drip tray (rev.00)
- 8. Maintenance schedule (rev.01)**
  - 8.1** Routine maintenance Check list (rev.01)
- 9. Exploded drawing (rev.00)**

# ***SECTION 1***

# ***INTRODUCTION***

**REV.00**

### **1.1 Documentation required**

The following technical documentation is required for repairs:

Instruction booklet for specific model  
Technical documentation for specific model (diagrams, exploded drawings)

### **1.2 Tools and equipment required**

As well as the standard equipment, the following tools are required.

- 1 Special screwdriver with Torx T15 tip and Pozi Drive screwdriver for casing and work on the coffee grinder.
- 1 Digital thermometer with full scale of 200°C  
Must be suitable for measuring in liquids and on surfaces.
- 1 set of pliers for Oetiker clamps
- 1 pincer

### **1.3 Safety warnings**

Before starting operations on the machine, consult the relative instruction booklet. Observe all current standards related to repairs of domestic appliances.

Always disconnect the power plug from the mains before carrying out repairs. Simply turning off the main switch is not sufficient to prevent electrical discharge.

This domestic appliance is rated with insulation class I.  
On completion of repairs the insulation and dielectric rigidity tests must be performed.

# ***SECTION 2***

# ***TECHNICAL DATA***

**REV.00**

## 2.1 Product and component technical data

Power supply and output:	230V AC, 50 Hz, 1500 W
Temperature control:	2 (NTC) variable resistor sensor - transmits the value to the electronic board
Safety system:	Thermostat at 170°C with manual reset on both heaters + 192° fuse
Coffee heat exchanger output: Stainless steel	1300 W - to dispense coffee and hot water
Steam heat exchanger output: Stainless steel	1090 W - to dispense steam
Motorized tank:	24v stepper motor
Water level sensor:	Capacitive sensor
Gearmotor:	DC motor (24 V) in two directions of rotation
Cup warmer plate:	Enabled via display "MENU Type PTC
Pump:	Ulk a reciprocating piston type with thermal cutout at 100°C 48W, 230V, 60 Hz, Type EP5 GW approx. 13-15 bar
Pressure relief valve:	Opening at approx. 17-19 bar
Water filter:	In tank
Coffee grinder:	DC motor with ceramic plate grinders
Coffee dose control:	Hall sensor - Pulse control. Optional coffee strength adjustment from approx. 7 - 10.5 g.
Multi-function valve:	Beverage selection control
Cappuccino valve:	Enables automatic frothing
Amps:	During heating phase- approx. 5.6 A
Energy consumption:	In Stand -By approx. 2.9 Wh In machine ready status, no beverages dispensed 53Wh
Dimensions: l x h x d in mm:	350/390/430
Weight:	14 kg
Water tank capacity:	1,75 0.32 l.
Coffee container capacity:	350 g. coffee in beans
Milk container capacity:	0.32 l.
Heat exchanger capacity:	Approx. 10 cc
Water circuit filling time:	Approx. 10 sec on first filling cycle
Heating time:	Approx. 45 sec.
Dispensed beverage temperature:	Approx. 73°C - 83°C
Grinding time:	Approx. 8-10 sec.

## 2.2 Internal / external machine components

### External:



**Internal:**



--- Gearmotor  
unit compartment

Water  
heater unit

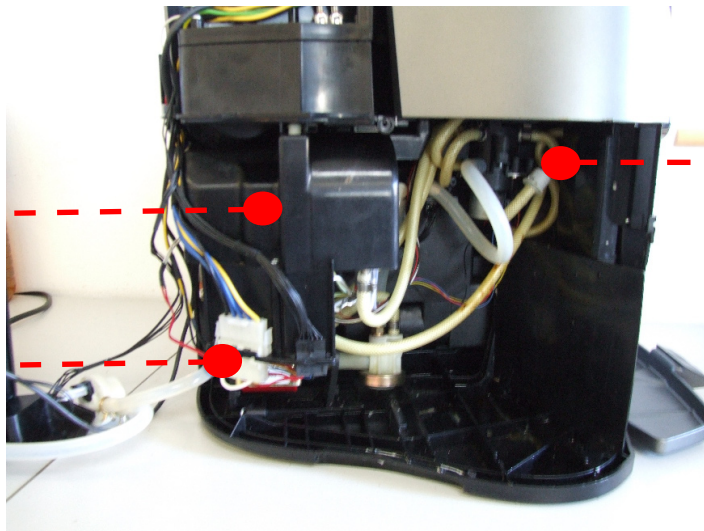

--- Multi-way valve

Pump unit

Cappuccinatore  
unit

Power board

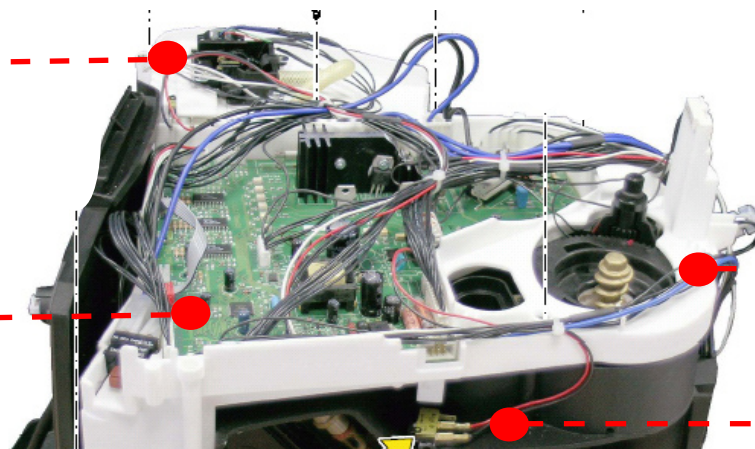

--- Coffee grinder

--- Door  
microswitch



***SECTION 3***  
***BRIEF***  
***INSTRUCTIONS***

**REV.01**

### 3.1 Client and programming menu

**Client menu:** to access, press "Programming menu"

The programming menu appears as illustrated below:

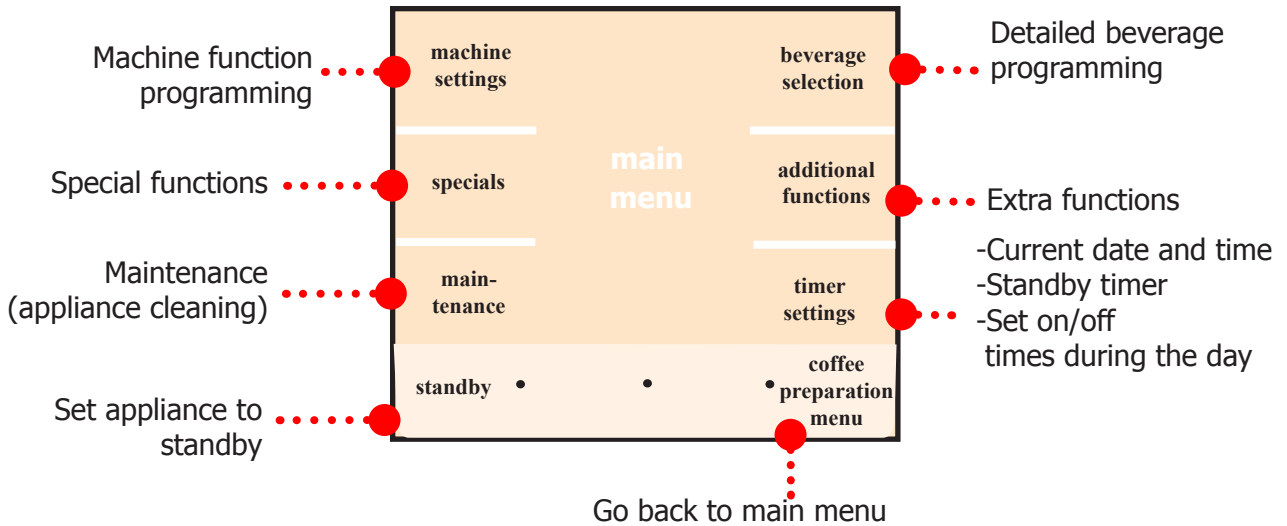

#### Sub-menu

**Machine settings:** adjust main machine parameters

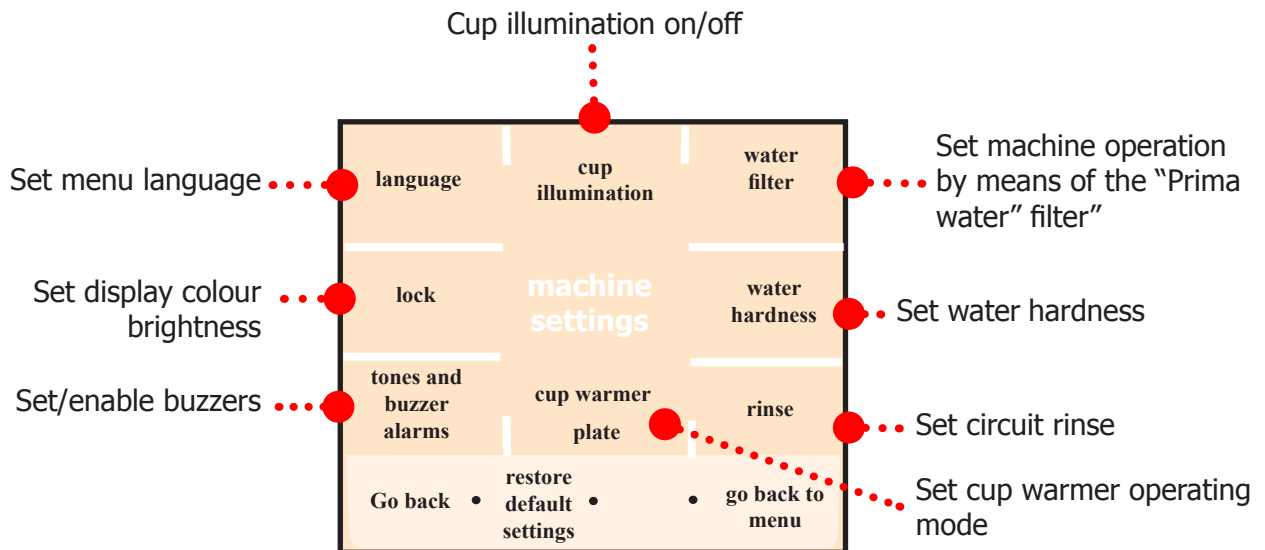

**Special functions: reset factory settings**

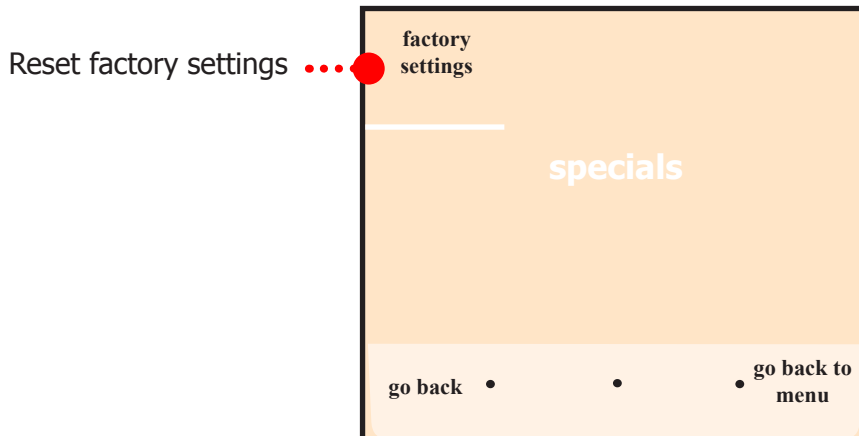

**Maintenance:** maintenance and appliance cleaning

From this menu, you can:

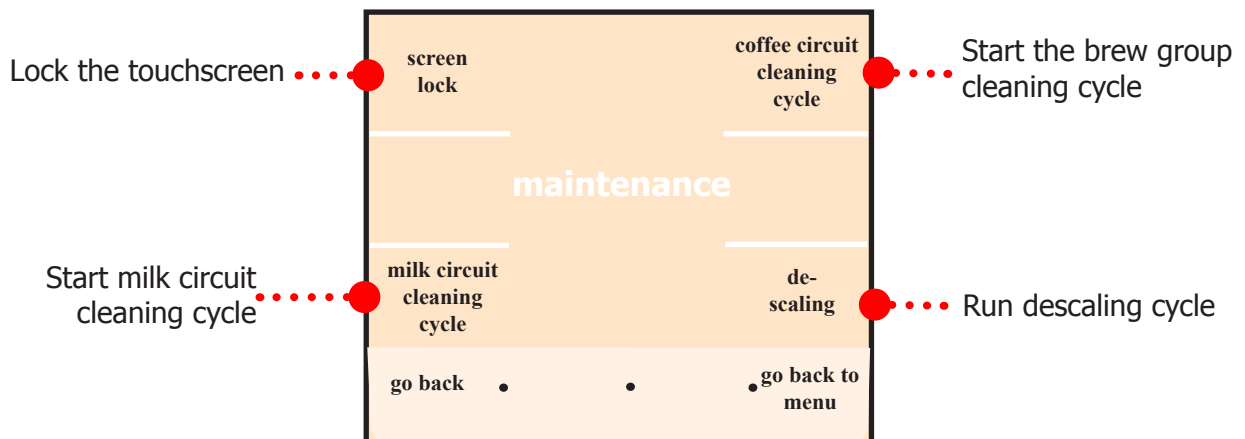

**Beverage settings:** programming single beverages

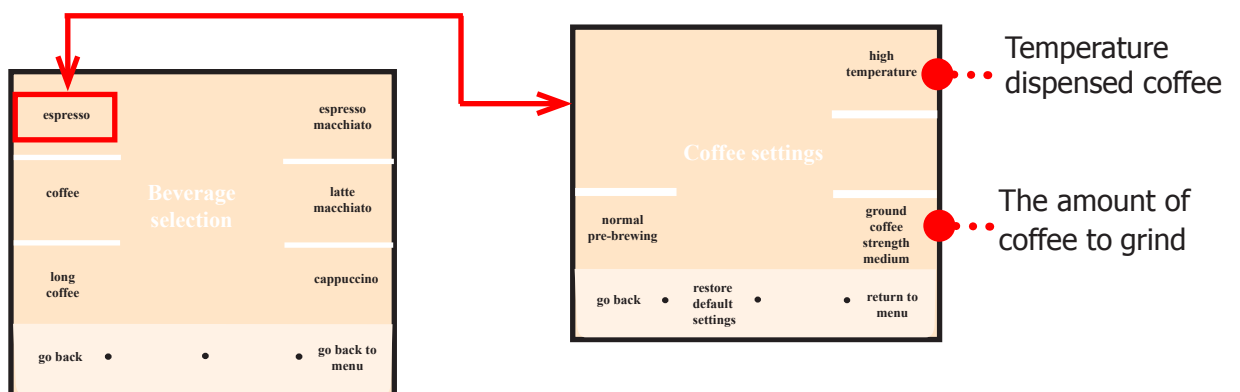

### Additional functions:

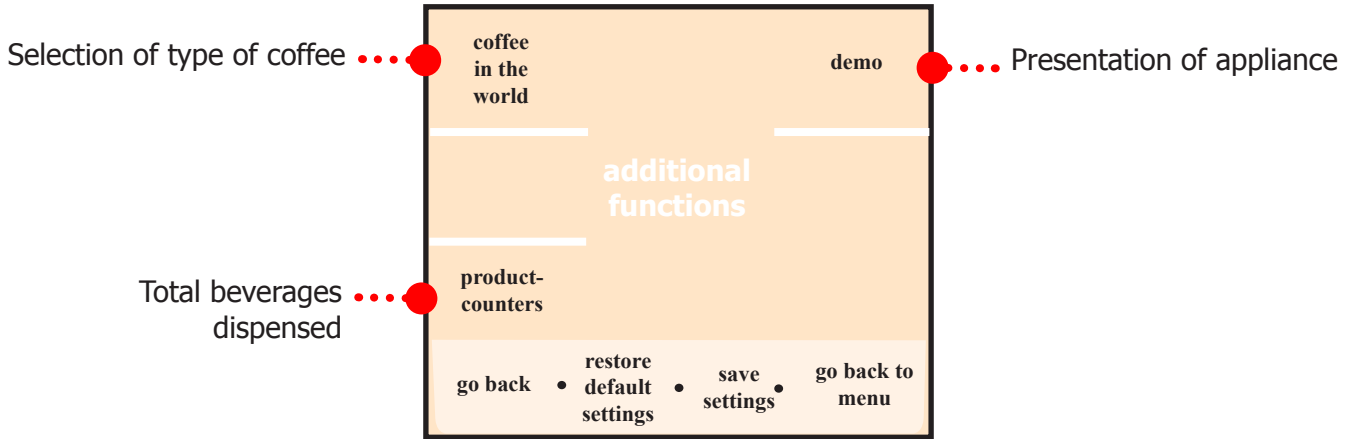

### Timer settings:

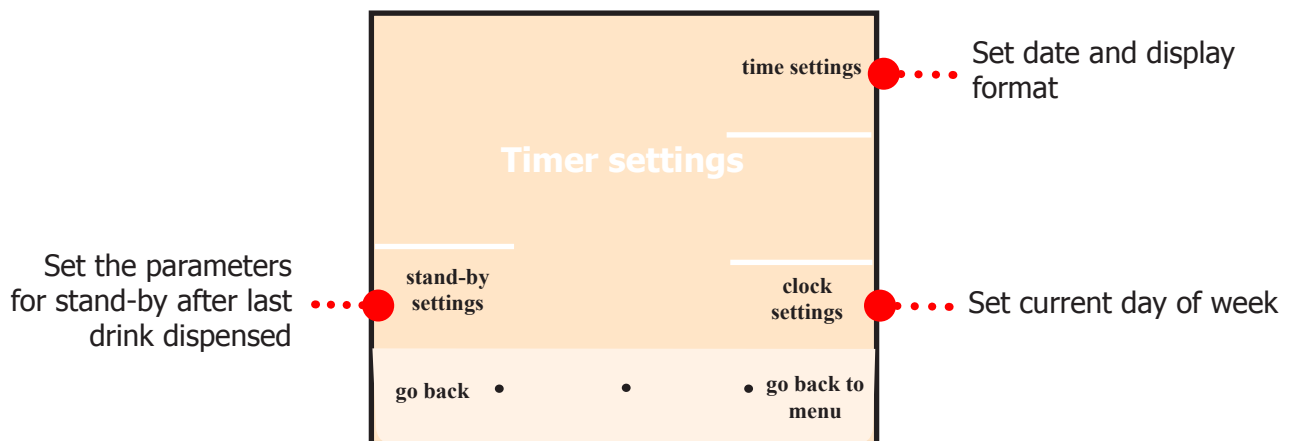

### 3.2 Maintenance and cleaning

STEPS		
A	Empty coffee grounds drawer	As instructed
B	Empty drip tray	As necessary
C	Clean water tank	Once a week
D	Clean the coffee bean container	As necessary
E	Clean casing	As necessary
F	Clean and grease the brew group	Once a month or every 500 coffees dispensed
G	Clean coffee unit filters	Once a month
H	Descaling	As instructed
I	Clean milk circuit	After each time milk dispensed
J	Clean drip tray	Once a week
K	Clean coffee circuit	Once a week

Descaling		
Hardness	Water hardness	descaling frequency *
1	Soft water (up to 7 <sup>o</sup> dH)	Around 3 months/120 litres
2	Medium water (7 <sup>o</sup> -14 <sup>o</sup> dH)	Around 2 months/90 litres
3	Hard water (15 <sup>o</sup> -21 <sup>o</sup> dH)	Around 6 weeks/60 litres
4	Very hard water (over 21 <sup>o</sup> dH)	Around 4 weeks/30 litres

\* Without Prima water filter

## Maintenance messages

Model	FUNCTION	Screen messages	Possible variations	Mode	Duration	Possibility of stopping/ changing
Primea Cappuccino Touch Plus	Milk	The appliance requests that the milk circuit is <b>pulse rinsed</b> right away, beverages can still be selected.		Press key or select from menu	Approx. 8-10 sec	No
		<b>If department is not rinsed within 20 minutes</b> , beverages can no longer be selected.	This refers to milk-based beverages only.	Press key or select from menu	Approx. 8-10 sec	No
		After <b>14 days</b> , the appliance requests that it is cleaned <b>with a cleaning tablet</b> .		Press key or select from menu	Approx. 10 minutes	During diagnosis
		If this is not done within <b>21 days</b> all beverages will be blocked.		Press key or select from menu	Approx. 10 minutes	During diagnosis
Primea Cappuccino Touch	Descaling	From when the descaling message appears, the appliance counts down internally from 200 coffees. After <b>100 the countdown appears on the display</b> then for <b>the last 30 coffees the message flashes</b> (200 coffees of any type and size in ml are counted).	The countdown for the whole 200 coffees is shown on the display.	Press key or select from menu	Approx. 45 minutes	During diagnosis
	milk	The appliance requests that the milk circuit is <b>pulse rinsed</b> right away, beverages can still be selected.		Press key or select from menu	Approx. 8-10 sec	No
		<b>If department is not rinsed within 20 minutes</b> , beverages can no longer be selected.	This refers to milk-based beverages only.	Press key or select from menu	Approx. 8-10 sec	No
		After <b>14 days</b> , the appliance requests that it is cleaned <b>with a cleaning tablet</b> .		Press key or select from menu	Approx. 25 minutes	During diagnosis
Primea Cappuccino Ring	Descaling	If this is not done within <b>21 days</b> all beverages will be blocked.		Press key or select from menu	Approx. 25 Min	During diagnosis
	Milk	From when the descaling message appears, the appliance counts down internally from 200 coffees. After <b>100 the countdown appears on the display</b> then for <b>the last 30 coffees the message flashes</b> (200 coffees of any type and size in ml are counted).	The countdown for the whole 200 coffees is shown on the display.	Press key or select from menu	Approx. 45 minutes	During diagnosis
		The appliance requests that the milk circuit is <b>pulse rinsed</b> right away, drinks can still be selected.		Press key or select from menu	Approx. 8-10 sec	No
		<b>If department is not rinsed within 20 minutes</b> , all <b>milk-based</b> beverages can no longer be selected.		Press key or select from menu	Approx. 8-10 sec	No
All models	Rinse coffee circuit	After <b>7 days</b> , the appliance requests that it is cleaned <b>with a cleaning tablet</b> .		Press key or select from menu	Approx. 25 minutes	During diagnosis, you can vary notification and block times, and during testing you can reset Liv. B mode
	Clean coffee circuit	If this is not done within <b>14 days</b> all drinks will be blocked.		Press key or select from menu	Approx. 25 minutes	During diagnosis, you can vary notification and block times, and during testing you can reset Liv. B mode
	Empty coffee grounds	From when the descaling message appears, the appliance counts down on the display from 200 coffees. Then for the last 30, the message flashes (200 coffees of any type and size in ml are counted).	From when the descaling message appears, the appliance counts down on the display from 200 coffees. Then for the last 30, the message flashes (200 coffees of any type and size in ml are counted).	The appliance counts down remaining coffees every 60 seconds for approx. 5 seconds.	Approx. 45 minutes	During diagnosis, you can vary notification and block times, and during testing you can reset Liv. B mode
	Aqua Prima	When ready, the coffee circuit is rinsed		The unit rises and releases 50ml water	Approx. 8-10 sec	This function can be disabled from the menu
	Runs only when selected.			The unit rises and releases approx. 600ml water in short spurts.	Approx. 25 minutes	During diagnosis
	After 24 coffees, the appliance requests that coffee grounds are removed.			Resets when coffee grounds drawer is extracted for 5 seconds with the appliance switched on.	Approx. 8-10 sec	During diagnosis
	60 litres or <b>90 days</b> from the first use of the appliance or after it has been unused for <b>20 days</b>			When enabled from the menu, approx. 500ml water is released.	Approx. 8-10 sec	No

# ***SECTION 4***

# ***DIAGRAMS***

**REV.00**

### 4.1 Wiring diagram Primea Touch Plus

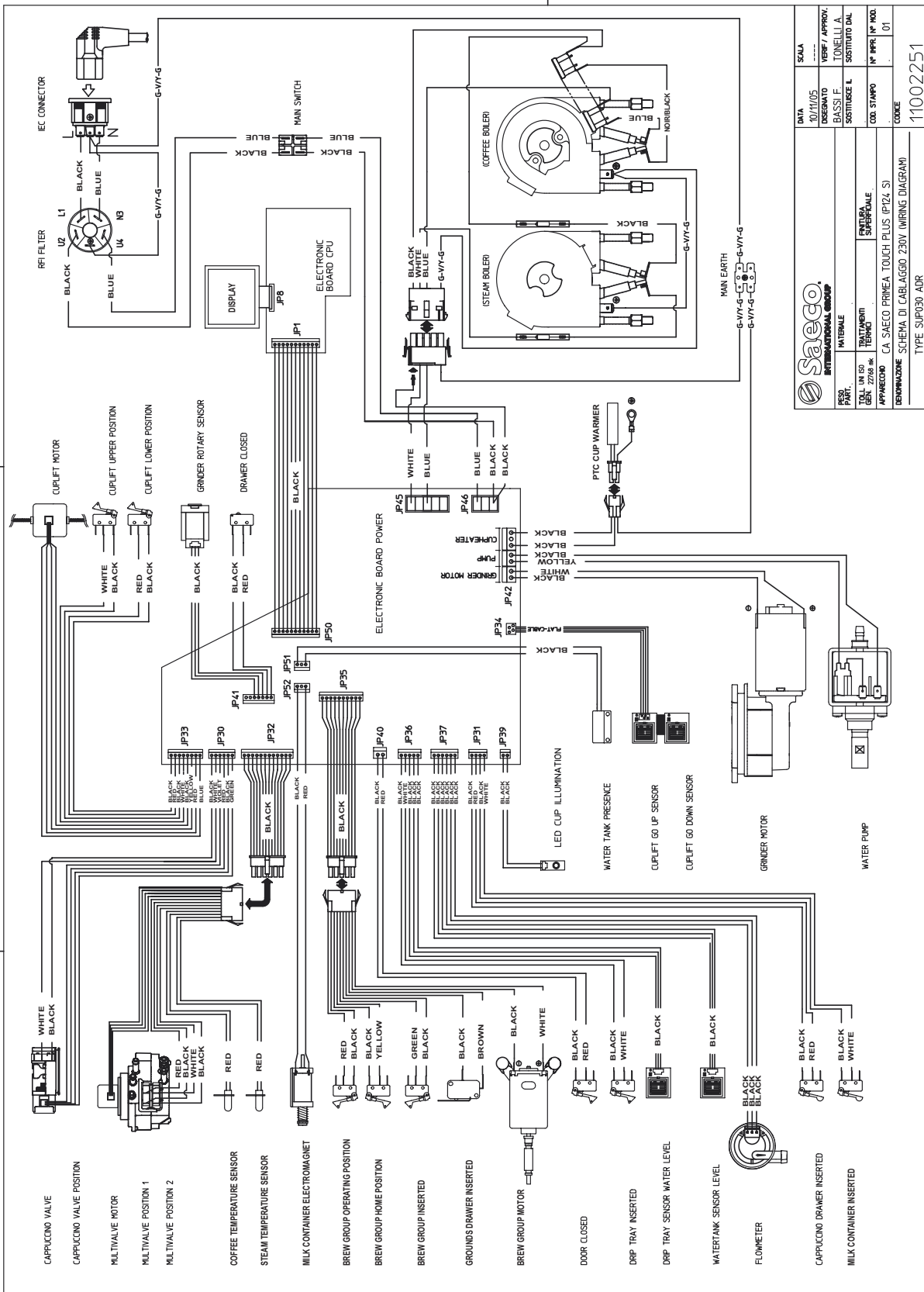

<b>Saeco</b> INTERNATIONAL GROUP		DATA	SCALA
DESIGNATO	10/11/05	VERIF. / APPROV.	---
SOSTITUITO DAL	BASSI F. TONELLI A.	TRATTAMENTO	---
APPARECCHIO	CA SAECO PRIMA TOUCH PLUS (PIZZA S)	TECNICI	---
RENOVAZIONE	SCHEMA DI CABLAGGIO 230V (WIRING DIAGRAM)	INTEGRAZIONE	---
GEN. 22/09/04		APPARECCHIO	---
APPARECCHIO	CA SAECO PRIMA TOUCH PLUS (PIZZA S)	COD. STAMPO	N° IMPR. / N° MOD. 01
RENOVAZIONE	SCHEMA DI CABLAGGIO 230V (WIRING DIAGRAM)	CODICE	11002251
TYPE SUP300 ADR			

LA PROPRIETA' DI QUESTO DOCUMENTO E' RISERVATA A TERMI DI LEGGE. E' VIETATO UNO RIPRODURLO E RENDERSI NOTO A TERZI.



Primea Touch

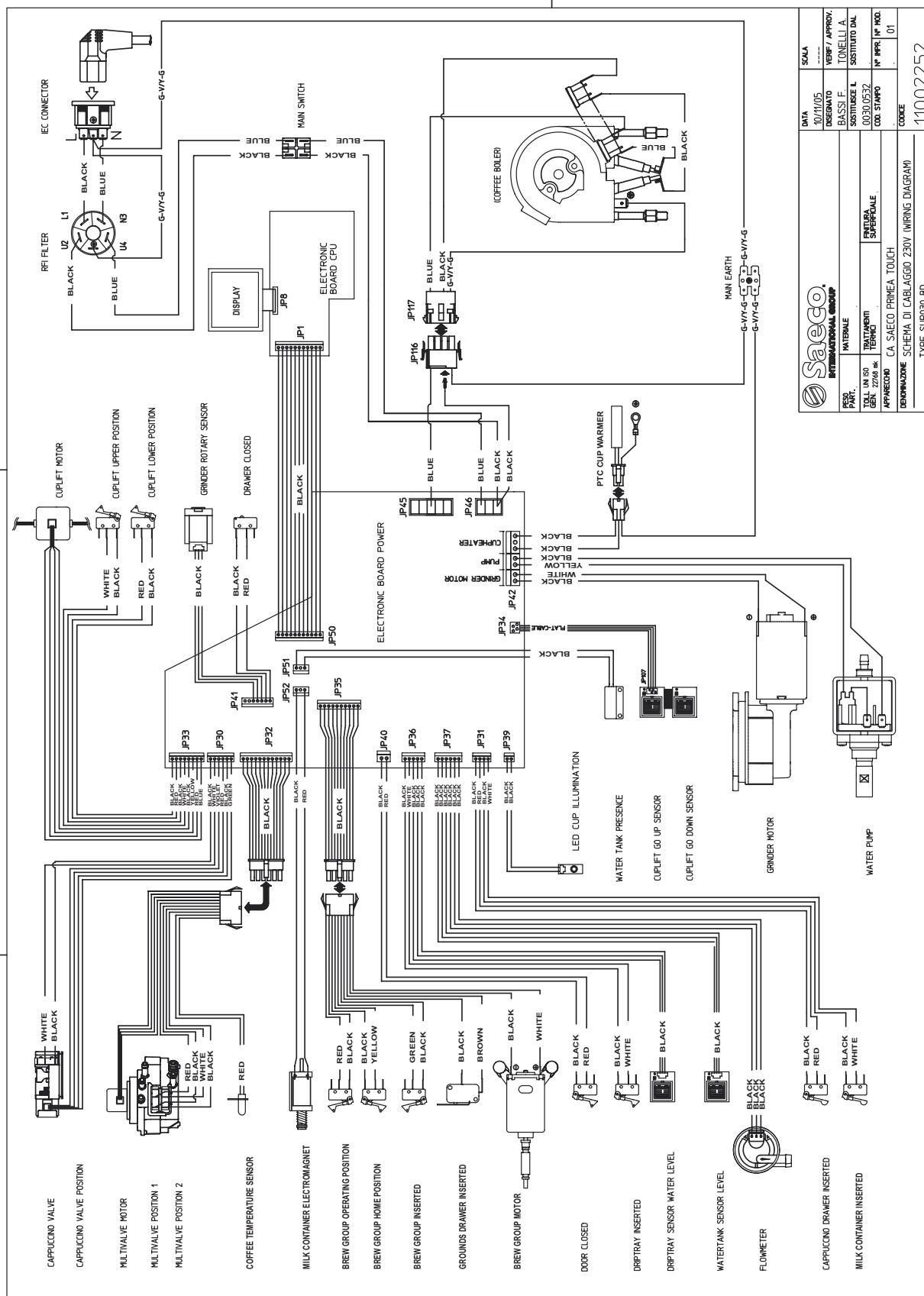

<b>Saeco</b> INTERNATIONAL GROUP		DATA	SCALA
DESIGNATO	10/71/05	VERIF. / APPROV.	---
DESIGNATO	BASSI F.	TONELLI A.	
SOSTITUIRE IL		SOSTITUITO DAL	
NUM. IDENT.	0030.0532	NUM. IDENT.	01
APPARECCHIO	CA SAECO PRIMEA TOUCH	NUM. IDENT.	01
DENOMINAZIONE		SCHEMA DI CABLAGGIO 230V (WIRING DIAGRAM)	11002252
TYPE		SUPP030 BD	

LA PROPRIETA' DI QUESTO DISEGNO E' RISERVATA A TERZI IN TUTTI I PAESI.

# Primea Ring

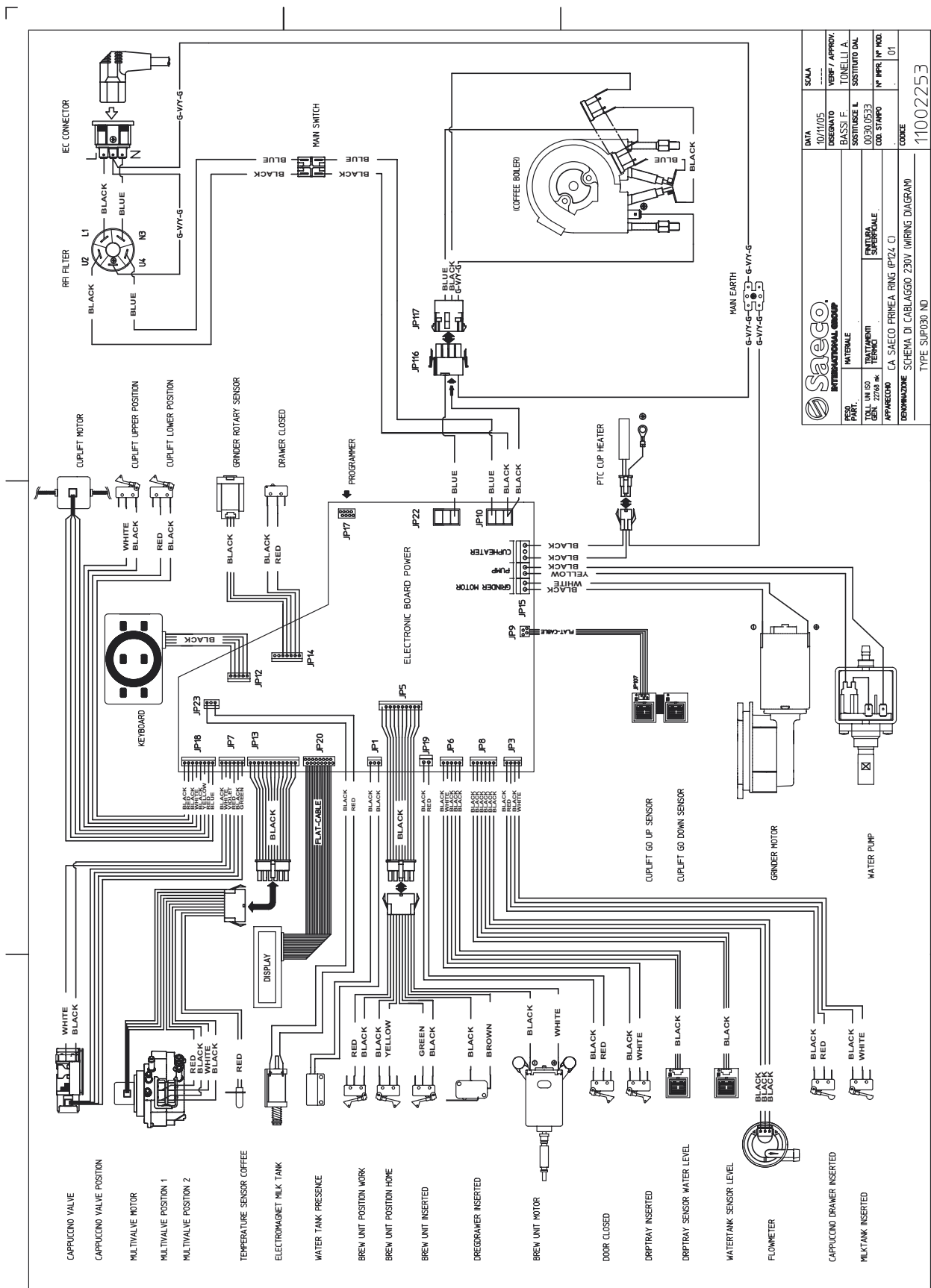

 INTERNATIONAL GROUP	SCALE	DATA
	VERIF. / APPROV.	10/11/05
	DESIGNATO	BASSI F. TONELLI A.
	SOSTITUISCE L.	0030.0533
	SOSTITUITO DAL	N° INPR. N° MOD.
PROD. PART.	MATERIALE	01
TOT. IN USI	TREATAMENTI	
GEN. 2708	TECNICI	
APPARECCHIO	CA. SAEKO PRIMEA RING (PT24. O)	
LEGNAPPARAZIONE	SCHEMA DI CABLAGGIO 230V (WIRING DIAGRAM)	
	TYPE SUPG030 IND	
		11002253

LA PROPRIETA' DI QUESTO DISEGNO E' RISERVATA A TERZI. VE'NIATO USATO RIPRODOTTO E RENDERO INTO A TERZI.

## 4.2 Component load table

Component	Connector	Pin number	Resistance/Voltage
Mains voltage/mains switch	JP 46	1/3	230 V AC
Autocappuccino motor	JP 30		304 Ohm 24 V AC
Cappuccino maker cam microswitch	JP 30	5/6	3,25 V DC
Milk container presence microswitch	JP 31	3/4	3,25 V DC
Cappuccino maker presence microswitch	JP 31	1/2	3,25 V DC
Drip tray motor	JP 33	1/2	90 Ohm 24V AC
	JP 33	3/4	91 Ohm 24V AC
Upper tank microswitch	JP 33	7/8	3,25 V DC
Lower tank microswitch	JP 33	5/6	3,25 V DC
Ulka pump	JP 42	3/4	730 Ohm 230V AC
Multi-valve motor	JP 32	5/6	90 Ohm 24V AC
	JP 32	7/8	90 Ohm 24V AC
Upper multi-valve microswitches	JP 32	9/10	3,25 V DC
Lower multi-valve microswitches	JP 32	11/12	3,25 V DC
Cup warmer	JP 42	5/7	approx. 560 Ohm 230 V AC
Steam heater sensor	1/2		61 Kilo Ohm x 19C°
Coffee heater sensor	3/4		61 Kilo Ohm x 19C°
Unit door microswitch	JP 40		24 V DC
Unit presence microswitch	JP 35	5/6	3,25 V DC
Gearmotor microswitches (up unit)	JP 35	3/4	3,25 V DC
Gearmotor microswitches (down unit)	JP 35	1/2	3,25 V DC
Coffee grounds drawer microswitch	JP 35	7/8	24 V DC
Drip tray microswitch	JP 36	4/5	3,25 V DC
Drip tray full capacitive sensor	JP 36	1/2	0 V DC
Empty drip tray capacitive sensor	JP 36	1/3	3,25 V DC
Gearmotor	JP 35	9/10	22 Ohm
Full tank capacitive sensor	JP 37	4/5	4,8 V DC
Empty tank capacitive sensor	JP 37	4/5	1,6 V DC
Tank operative capacitive sensor	JP 37	5/6	4,8 V DC
Coffee container cover microswitch	JP 41	6/7	3,25 V DC
Coffee heater 1300W	JP 45	3	39 Ohm 230 V AC
Cup illumination ON led	JP 39		2,0 V DC
Motor-driven tank capacitive key activated	JP 34		4 V DC
Motor-driven tank capacitive key not activated	JP 34		0 V
Coffee grinder	JP 42	1/2	64 Ohm approx. 250 V DC
Coffee grinder absorption - coffee container empty			Approx. 200 mA
Coffee grinder absorption - coffee container full			Approx. 400-450 mA

Fuse F1 T8A - 230V AC  
 Fuse F2 T8A - 230V AC  
 Fuse F1 T1A

To protect the coffee grinder, coffee heater, cup warmer and pump.  
 To protect the steam heater.  
 To protect the card on the external mains power supply.

4.3 Water circuit diagram  
Primea Touch Plus

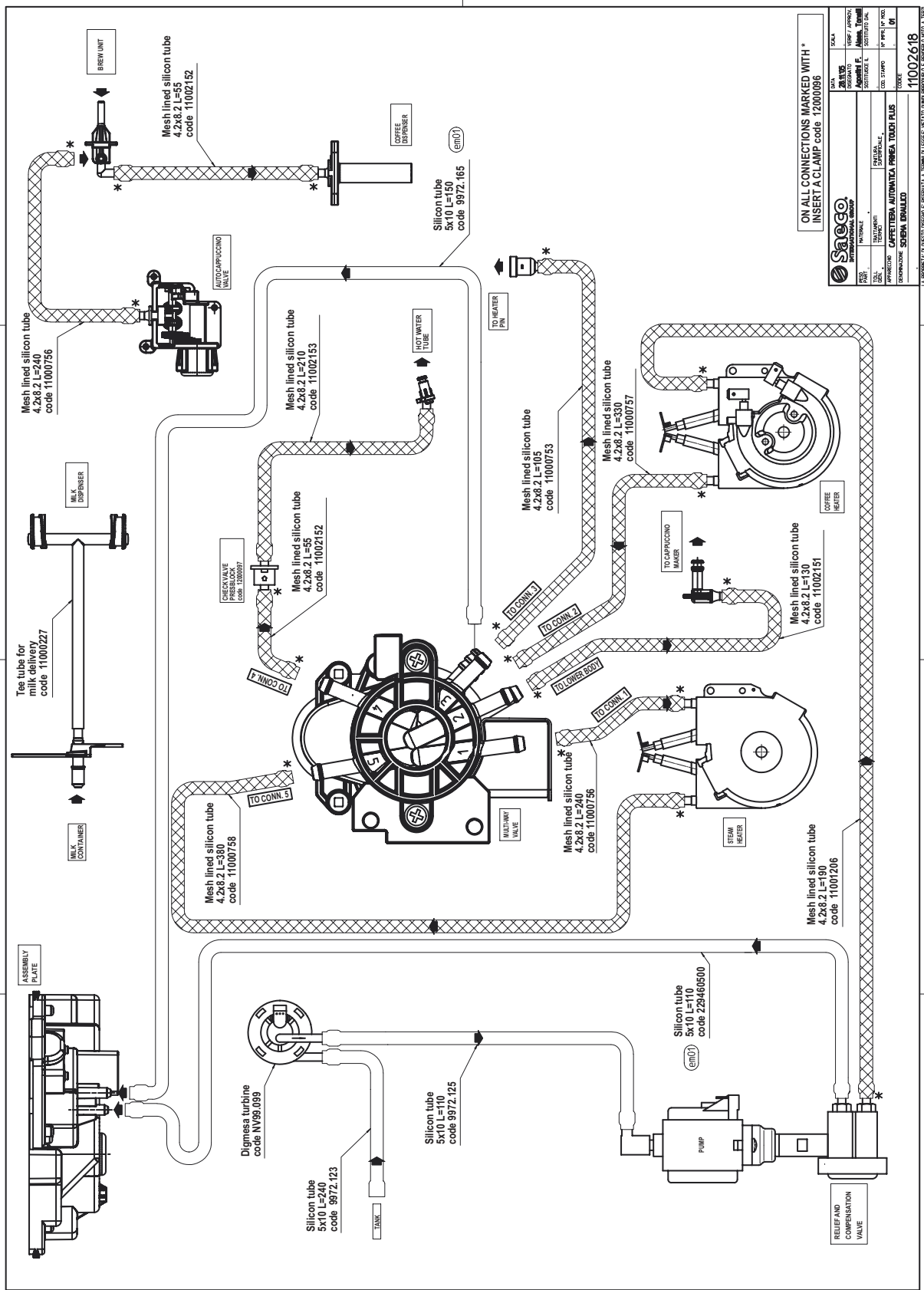

Primea Touch / Ring

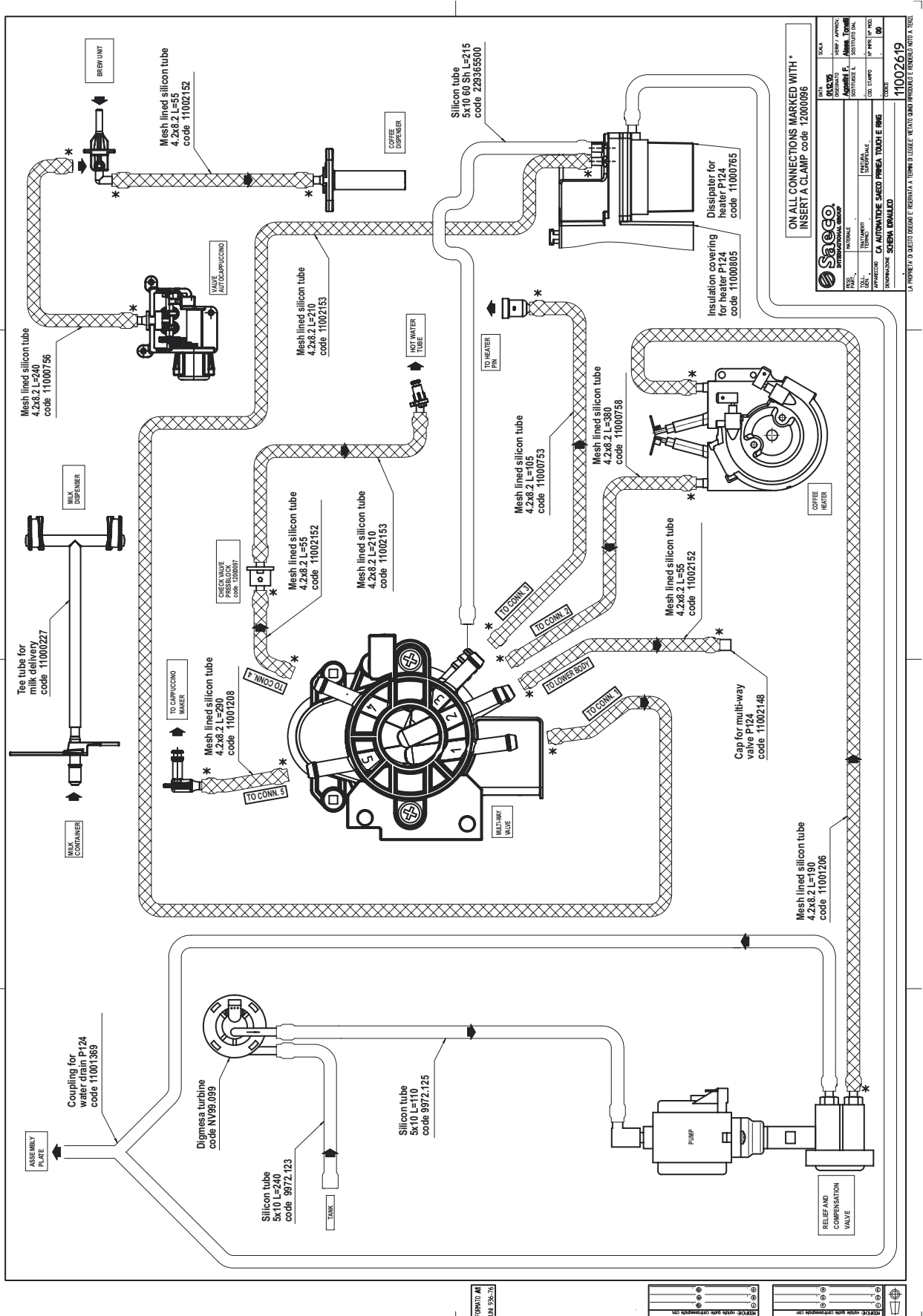

# ***SECTION 5***

# ***TROUBLESHOOTING***

**REV.01**

### 5.1 e Primea Touch Plus and Touch test functions

The functions of the second water heater do not apply to the Touch model.

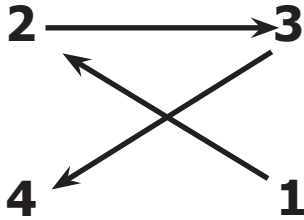

During the first 3 seconds after start-up of the appliance (or on exit from standby mode) the user can access test mode by pressing the keys in the sequence shown alongside.  
 In test mode, the machine functions can be checked, and are divided into four macro-groups.

CPU print software version:  
V\_00.00.00

power print software version:  
V\_00.00.00

CPU print boot loader version:  
V\_00.00.00

**ESC**

---

brew group	multi valve	cup lift	software
grinder	• capp.valve	•illumination•	version
heater	pump	cup warmer	ESC

The display shows:

- CPU card software version
- Power card software version
- Description of functions
- Esc key to exit Test Mode
- Version of boot loader on CPU

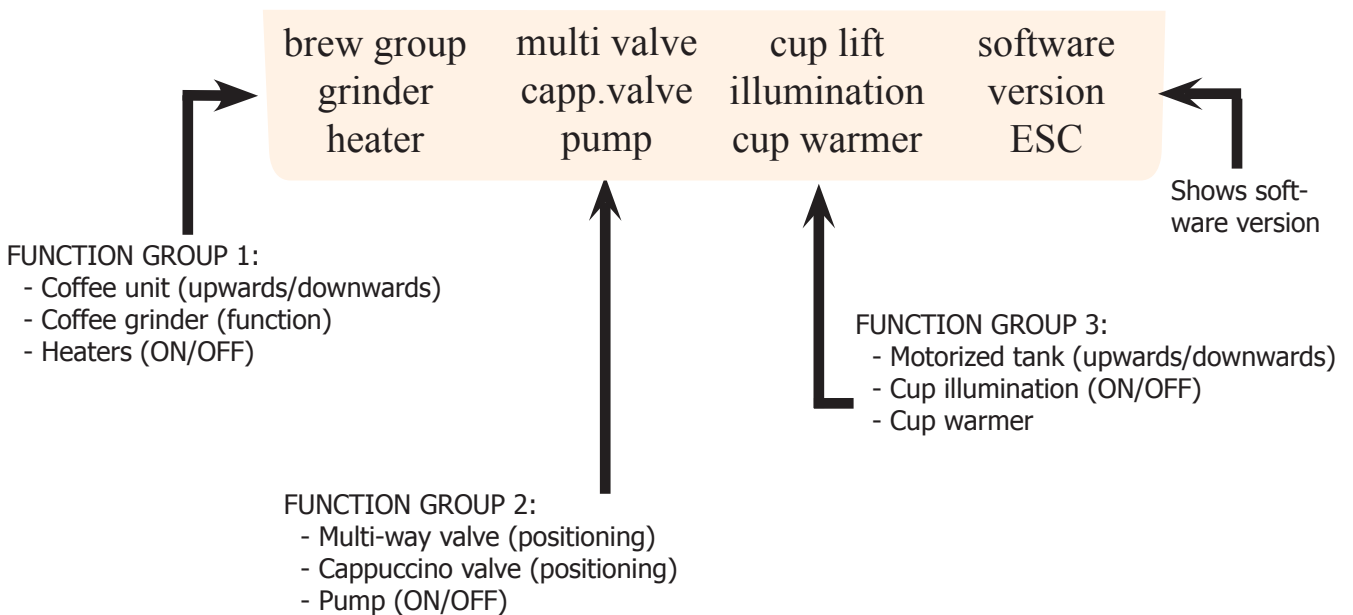

### 5.1.1 Function group 1 - coffee unit, coffee grinder, heater power supply

brew group home	Brew group	Errors	brew group work
		Grounds drawer:OK Door:OK WaTank:OK	
grinder go	inserted	WaLevel:OK DripWater:OK	water heater (1300W)
	Grinder Imp:000	MilkTank:OK CappDraw:OK Tray miss:OK	
Impulses Med. Aroma 100	Top open	Sensor	steam heater (1100W)
		St:100:OK Wa:100:OK	
brew group	multi valve	cup lift	software
grinder	• capp.valve	• illumination	version
heater	pump	cup warmer	ESC

Brew group home: Brew group is home position (garmotor micro)  
 Brew group work: Brew group in dispensing position (garmotor micro)  
**Brew group:** inserted - unit inserted (Group Micro)  
 missing - unit missing (Unit Micro)  
 Grinder go: Coffee grinder running  
**Grinder:** Imp:000 - coffee grinder pulses  
 Top open - coffee container lid open  
 Top closed - coffee container closed  
 Steam heater: 1100W - powers steam heater  
 Water heater: 1300W - powers water heater  
**Sensor:\*** Max 150  
 Impulses Coffee grinder pulse control (min - max.200) in Steps of 05  
 Med.Aroma Sets quantity of ground coffee

### Function group 2 - multi-way valve, cappuccinatore valve, pump

multi valve left	Multival:OK	Errors	multi valve right
	Pos3:Init Ms: Top Ms: Bot	Dregdraw:OK Door:OK WaTank:OK	
capp.valve next position	Cupp.Valve	WaLevel:OK DripWater:OK	pump
	reached Pos1:Init MS: open	MilkTank:OK MilkDraw:OK CappDraw:OK Tray miss:OK	
solenoid	Flowmeter	Sensor	
	Imp.:000 Hz:000	St:100:OK Wa:100:OK	
brew group	multi valve	cup lift	software
grinder	• capp.valve	• illumination	version
heater	pump	cup warmer	ESC

Multi valve left: Turnmulti-way valve left  
 Multi valve right: Turnmulti-way valve right  
**Multival:OK** Multi-way valve OK or faulty (ER)  
**Pos1:Steam** Steam setting (hot milk and froth)  
**Pos2:St.Pre.** Steam pressure before milk or froth dispensed  
**Pos3:Init** Reset position - initialisation  
**Pos4:Coffee** Coffee dispense setting  
**Pos5:Hotwa.** Hot water dispense setting  
 Cupp.valve next: Cappuccino valve command position  
**Pos1:Init** Reset position - initialisation  
**Pos2:Foam** Milk frothing setting  
**Pos3:Milk** Hot milk dispense setting  
 Pump: Pump  
**Turbo:OK** Pump OK or faulty (ER)  
**Imp.:000** Turbine pulses (40 - 60 OK)  
**Hz:** 000  
 Solenoid: Activation of electromagnet that locks the milk door

### Function group 3 - drip tray, cup illumination, cup warmer

cuplift up	Cuplift	Errors	cup heater
	bottom Key up:Off Key down:Off	Dregdraw:OK Door:OK WaTank:OK WaLevel:OK	
cuplift down		DripWater:OK MilkTank:OK MilkDraw:OK Tray miss:OK	
		Sensor	
illumination		St:100:OK Wa:100:OK	
	brew group	multi valve	cup lift
grinder	• capp.valve	• illumination	software
heater	pump	cup warmer	version
			ESC

Cuplift up: Tank up movement  
 Cuplift down: Tank downwards movement  
 Cuplift: Tank downwards (lower micro)  
**Is bottom:** Tank up (upper micro)  
**Is Top** ON/OFF-Up key pressed  
**Key up: OFF** ON/OFF-Down key pressed  
**Key down: OFF** Cup illumination (press and hold)  
 Illumination: Cup warmer plate (press and hold)  
 Cup warmer

**Key:** In black: Keys  
 In blue: Check status  
 \* See overleaf (sensors)



### 5.1.2 Microswitch and sensor check

#### Errors

(Errors)

Dreg drawer: (Dregdraw:)	Coffee grounds drawer Micro OK Drawer present ER Drawer missing
Service: (Door:)	Door microswitch OK door closed ER door open
Water tank: (WaTank:)	Tank Micro OK tank engaged ER tank empty or in reserve (see diagnostics)
Water level: (WaLevel)	Water level capacitive sensor OK Water present ER Water low
Drip tray: (DripWater:)	Drip tray capacitive sensor OK drip tray empty ER drip tray full
Milk container: (MilkTank)	Milk container door micro OK milk container door closed ER milk container door open
Cappuccinatore: (CappDraw:)	Milk container + cappuccinatore micro OK Milk container and cappuccinatore inserted ER milk container
Drip tray: (no drip tray) (Tray miss:)	Drip tray micro OK trip present ER no tray

#### Sensors

St: steam	Steam heater temperature sensor (Touch Plus only) Number: current temperature OK Sensor connection ok ER sensor shorted or disconnected
Wa: water	Water heater temperature sensor Number: current temperature OK Sensor connection ok ER sensor shorted or disconnected

#### Errors

Dregdraw:OK  
Door:OK  
WaTank:OK  
WaLevel:OK  
DripWater:OK  
MilkTank:OK  
CappDraw:OK  
Tray miss:OK

#### Sensor

St:100:OK  
Wa:100:OK

## 5.2 Touch Plus and Touch diagnosis function

The functions of the second water heater do not apply to the Touch model.

Procedure for access to diagnostics mode.

Turn the appliance off and then on again or exit standby mode to enter the diagnostics menu, according to the sequence shown in the figure.

For access to the diagnostics menu there is a timeout limit of 3 sec. between one selection and the next .(1,2,3,4)

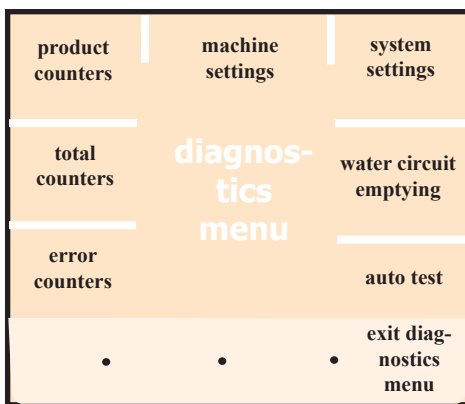
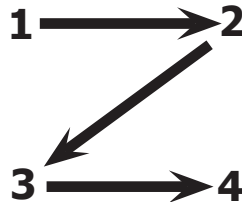

A window is displayed showing the following options:

- Product counters
- Total counters
- Error counters
- Product settings
- System settings
- Steamout (circuit emptying)
- Auto test
- Exit diagnostics menu

Description of options available

### 5.2.1 Beverage counters

Total hot milk beverages

- Total beverages
- Beverage dispense time (sec.)

not modifiable  
not modifiable

Total latte macchiato beverages

- Total beverages
- Water used (ml.)

not modifiable  
not modifiable

Total cappuccino beverages

- Total beverages
- Water used (ml.)

not modifiable  
not modifiable

Total espresso macchiato beverages

- Total beverages
- Water used (ml.)

not modifiable  
not modifiable

Total hot water beverages

- Total beverages
- Water used (ml.)

not modifiable  
not modifiable

Total long coffee beverages

- Total beverages
- Water used (ml.)

not modifiable  
not modifiable

Total coffee beverages

- Total beverages
- Water used (ml.)

not modifiable  
not modifiable

Total espresso beverages

- Total beverages
- Water used (ml.)

not modifiable  
not modifiable

Total pre-ground coffee beverages	
• Total beverages	not modifiable
• Water used (ml.)	not modifiable
Total all beverages	
• Total beverages	not modifiable

### 5.2.2 Total counters

Water used since production (ml.)	not modifiable
Water used since last descaling message (ml.)	not modifiable
Water used since last descaling (ml.)	not modifiable
• water used counter - last (ml.)	
• water used counter - penultimate (ml.)	
• water used counter - third to last (ml.)	not modifiable
Total descaler used	not modifiable
Water used (ml.)	
Water used since last reset of filter (ml.)	not modifiable
Water used with water filter enabled since production (ml)	not modifiable
Number of descalings (cycles)	not modifiable
Number of brew group cleaning cycles	not modifiable
Number of milk circuit rinse cycles	not modifiable
Number of cappuccino maker cleaning cycles	not modifiable
Water filters used since production (cycles)	not modifiable
Number of brew group removals (cycles)	not modifiable
Products up to descaling (cycles)	not modifiable
Machine active time (sec.)	not modifiable
Temporary descaling counter	not modifiable
Water circuit emptying counter (cycles)	not modifiable

### 5.2.3 Error counters (access submenu)

The machine records the following errors (see also para. 5.3)

- 01) Coffee grinder 1 blocked
- 02) Coffee grinder 2 blocked
- 03) Brew group blocked; up command
- 04) Brew group blocked; down command
- 05) Pump flow rate error
- 06) Multivalve blocked
- 07) Capp. valve. blocked
- 08) Powercomm error (communication error with power card)
- 09) Water heater sensor disconnected
- 10) water heater sensor short circuit
- 11) Steam heater sensor disconnected
- 12) Steam heater sensor short circuit
- 13) Water heater disconnected
- 14) Steam heater disconnected

All these errors display the following submenu

- |                             |                         |
|-----------------------------|-------------------------|
| • Production errors         | not modifiable          |
| • Errors since last service | resettable - modifiable |
| • Current                   | resettable - modifiable |

ringbuffer errors: the last 20 errors are saved.

- Error 1/20,2/20,3/20,4/20,5/20,6/20,7/20,8/20,9/20,10/20,11/20,12/20,13/20,14/20,15/20,16/20,17/20,18/20,19/20,20.

## 5.2.4 Ringbuffer repair code

### Buffer history repair

This area records interventions of the Service Centres (up to a maximum of 10).

The Service Centre enters **the fault codes via PC** as transmitted by Saeco I.G. (e.g: CLD01)

1.group errors  
 1.code errors  
 1.day errors  
 1.month errors  
 1.year errors

2.....

10.group errors  
 10.code errors  
 10.day errors  
 10.month errors  
 10.year errors

### Machine status (all modifiable)

- **1** Prime circuit (yes/no)
- **2** Water filter (enable/disable command)
- **4** Unit full (yes/no)
- **8** Display add coffee coffee grinder 1 (yes/no)
- **16** Display add coffee coffee grinder 2 (yes/no)
- **32** Time format (am/pm)
- **64** Standby (yes/no)
- **128** Rinse (enable/disable)
- **256** Cup illumination (enable/disable)
- **512** Coffee grinder 1 coffee missing (warning management) sec.
- **1024** Coffee grinder 2 coffee missing (warning management) sec.
- **2048** Milk circuit rinse required (yes/no)
- **4096** Demo mode (disable/enable) command
- **16384** Display icons (yes/no)
- **32768** Warning tone ready (enable/disable)
- **65536** Milk quality warning (enable/disable)
- **131072** Key press tone (enable/disable)

## 5.2.5 Beverage settings

BEVERAGE SETTING parameters	Unit of measurement	Settings range	Default value
<b>HOT MILK</b>			
Beverage data modified by user		yes/no	no
Milk time	seconds	0 ... 40	25
Froth time	seconds	0 ... 40	0
<b>LATTE MACCHIATO</b>			
Beverage data modified by user		yes /no	no
Temperature		low, high, medium	medium
Aroma		medium, light, pre-ground, strong	medium
Use of 2 coffee grinders (* for version with two coffee grinders)	percentage	0 = left cg only 100 = right cg only	100
Pre-brewing		disabled, strong, normal	normal
Water	turb. pulses.	50 ... 450	135
Milk time	seconds	0 ... 40	0
Froth time	seconds	0 ... 40	27
<b>CAPPUCCINO</b>			
Beverage data modified by user		yes /no	no
Temperature		low, high, medium	medium
Aroma		medium, light, pre-ground, strong	medium
Use of 2 coffee grinders (* for version with two coffee grinders)	percentage	0 = left cg only 100 = right cg only	100
Pre-brewing		disabled, strong, normal	normal
Water	turb. pulses.	50 ... 450	135
Milk time	seconds	0 ... 40	0
Froth time	seconds	0 ... 40	22
<b>ESPRESSO MACCHIATO</b>			
Beverage data modified by user		yes /no	no
Temperature		low, high, medium	medium
Aroma		medium, light, pre-ground, strong	medium
Use of 2 coffee grinders (* for version with two coffee grinders)	percentage	0 = left cg only 100 = right cg only	100
Pre-brewing		disabled, strong, normal	normal
Water	turb. pulses.	50 ... 450	135
Milk time	seconds	0 ... 40	0
Froth time	seconds	0 ... 40	9
<b>HOT WATER</b>			
Beverage data modified by user		yes /no	no
Water	turb. pulses.	50 ... 450	210
<b>LONG COFFEE</b>			
Beverage data modified by user		yes /no	no
Temperature		low, high, medium	medium
Aroma		medium, light, pre-ground, strong	medium
Use of 2 coffee grinders (* for version with two coffee grinders)	percentage	0 = left cg only 100 = right cg only	100
Pre-brewing		disabled, strong, normal	normal
Water	turb. pulses.	50 ... 450	440
<b>COFFEE</b>			
Beverage data modified by user		yes /no	no
Temperature		low, high, medium	medium

Aroma		medium, light, pre-ground, strong	medium
Use of 2 coffee grinders (* for version with two coffee grinders)	percentage	0 = left cg only 100 = right cg only	100
Pre-brewing		disabled, strong, normal	normal
Water	turb. pulses.	50 ... 450	280
<b>ESPRESSO</b>			
Beverage data modified by user		yes /no	no
Temperature		low, high, medium	tall
Aroma		medium, light, pre-ground, strong	medium
Use of 2 coffee grinders (* for version with two coffee grinders)	percentage	0 = left cg only 100 = right cg only	100
Pre-brewing		disabled, strong, normal	normal
Water	turb. pulses.	50 ... 450	165
<b>EXTRA MILK</b>			
Time	seconds	0 ... 40	5

### 5.2.6 System settings

SYSTEM SETTING parameters	Unit of measurement	Settings range	Default value
<b>SETTING</b>			
Water heater temperature enabled	°C	70 ... 150	130
Water heater temperature disabled	°C	70 ... 150	115
Steam heater temperature enabled	°C	70 ... 150	145
Steam heater temperature disabled	°C	70 ... 150	130
Normal cup temperature	°C	70 ... 150	78
Last use of brew group	min/sec	0 - 59 ; 0 - 59	0
Last use of brew group	d/h	1-7 ; 0-23	0
<b>PRODUCT PARAMETERS</b>			
Hot water	flow rate (l/h)	5 ... 31	18
Hot milk (steam pressure time)	seconds	0 ... 40	6
Hot milk (pulse length)	line-period	1 ... 3	3 (=60ms / 50Hz)
Hot milk (pulse period)	20ms - steps	5 ... 250	30 (=600ms)
Milk froth (steam pressure time)	seconds	0 ... 40	6
Milk froth (pulse length)	line-period	1 ... 3	2 (=40ms / 50Hz)
Milk froth (pulse period)	20ms - steps	2 ... 90	30 (=600ms)
<b>MILK CIRCUIT RINSE</b>			
Distribution time	seconds	0 ... 40	10
Steam pressure time	seconds	0 ... 40	6
Pulselength	line-period	1 ... 3	1 (= 20ms / 50Hz)
Pulse period	20ms - steps	5 ... 250	15 (=300ms)
<b>MILK CIRCUIT CLEANING</b>			
Milk circuit (first use in day)	day	1-31	0
Milk circuit (first use in month)	month	1-12	0
Milk circuit (first use in year)	year	2005-2099	2099
Milk circuit cleaning (status)		complete	0
Milk circuit cleaning (distribution time)		0 ... 40	30
Milk circuit cleaning (steam pressure time)		0 ... 40	6
Milk circuit cleaning (pulse length)	line-period	1 ... 3	1 (= 20ms / 50Hz)
Milk circuit cleaning (pulse period)	20ms - steps	5 ... 250	15 (=300ms)
Milk circuit cleaning (detergent wait time)	minutes	0 ... 60	5
<b>DESCALING STATUS</b>			
Status	complete, dec. rinse start, dec.finished, normal quantity, start. quantity		
<b>Brew group CLEANING</b>			
Status	complete, finished dispensing, quantity 4-3-2-1 dispensed		
<b>Machine status *</b>			
Machine status *		complete	---
Language		0 ... 11	0
Water hardness		1 ... 4	3
Display brightness		50 ... 100	80
Cup warmer		disabled, always on, off in standby	disabled
Grinder adjustment	Coffee grinder pulses	60 ... 200	100
Off time	hours and minutes	0-3 ; 0-59	3
Real time clock (calendar used)**	days, hours, seconds	complete	0
Production date	dd/mm/yy	not modifiable	not modifiable
Service date	dd/mm/yy	complete	0

Milk quality warning	minutes	0 ... 60	20
Milk rinse alarm time	minutes	5...240	20
Power board status		complete	0
Water filter	dd/mm/yy	complete	2006
Water filter - last appliance start-up	dd/mm/yy	complete	2006
Stop coffee grounds	nr. grounds	0 ... 25	24
Coffee grounds counter	nr. grounds	0 ... 25	24
Water reserve limit	turbine pulses	0 ... 2000	750
Water reserve counter	turbine pulses	0 ... 2000	0
Software version	boards cpu bootloader power		
Serial number		complete	

\* Enter machine status

\*\* The day hours and minutes of machine start-up and shutdown can be programmed in three time bands

### 5.2.7 Steam outlet/ emptying water circuit

This option must be run when the coffee maker is delivered by courier in periods subject to winter temperatures. This function prevents damage to the appliance caused by very low temperatures.

The cycle empties the water circuit by means of the following sequence of operations performed automatically.

- Selection of functions in diagnostics menu
  1. The multivalve must be in coffee position
  2. Both heaters reach the temperature of 130°C
  3. The unit sets to the work position (UP) for 3 sec.
  4. The unit returns to the home position (DOWN)
  5. The multivalve sets to the hot water position for 1 sec.
  6. The multivalve sets to the steam position for 1 sec.



### 5.2.8 Auto test

On selection of this function, an automatic test is run on the machine functions, with results reported on the display. Before starting the test, all drawers and the tank must be inserted, all doors closed and the relative recipients must be filled with water and coffee.

Test type	Description	Message if function OK	Error message
2.7.1 External ram test	Check CPU ram	successful !	failed !
2.7.2 Flash test	Check CPU flash memory	successful !	failed !
2.7.3 Eeprom test	Check non volatile memory with machine settings	successful !	failed !
2.7.4 RTC test	Check real time clock	successful !	failed !
2.7.5 Cup lift test upwards	The motorized tank moves up and engages the upper microswitch	successful !	failed !
2.7.6 Cup lift test downwards	The motorized tank moves down and engages the lower microswitch	successful !	failed !
2.7.7 Capp valve test	Check correct operation of the cappuccinatore and relative microswitch	successful !	failed !
2.7.9 Multivalve test	Check correct operation of multivalve and relative microswitches	successful !	failed !
2.7.10 Pump test	Check pump and turbine operation. WARNING: hot water delivered	successful !	failed !
2.7.11 Grinder test	Check coffee grinder and coffee presence, as well as hall sensor which counts pulses	successful !	failed !
2.7.12 Brew group test upwards	Check ascent of unit and activation of the upper limit microswitch	successful !	failed !
2.7.13 Brew group test downwards	Check descent of unit and activation of the lower limit microswitch.	successful !	failed !
2.7.14 Water heater test	Check and inspection of power to coffee/water heater, if the sensor detects increase in temperature.	successful !	failed !
2.7.15 Steam heater test (Touch Plus only)	Check and inspection of power to steam heater, if the sensor detects increase in temperature.	successful !	failed !

At the end of the automatic cycle, you can "repeat the automatic test "or "exit the test "as required".

#### Exit from diagnostics

On selection of this option, the system exits the diagnostics menu and returns to the normal machine functions.

### 5.3 Ring test function

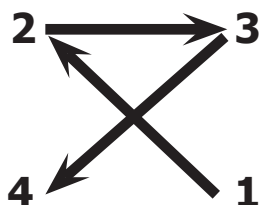

During the first 3 seconds after start-up of the appliance (or on exit from standby mode) you can access test mode by pressing the keys in the sequence shown alongside. Turn the control click-wheel (P) (I-Pod) for access to each different level.

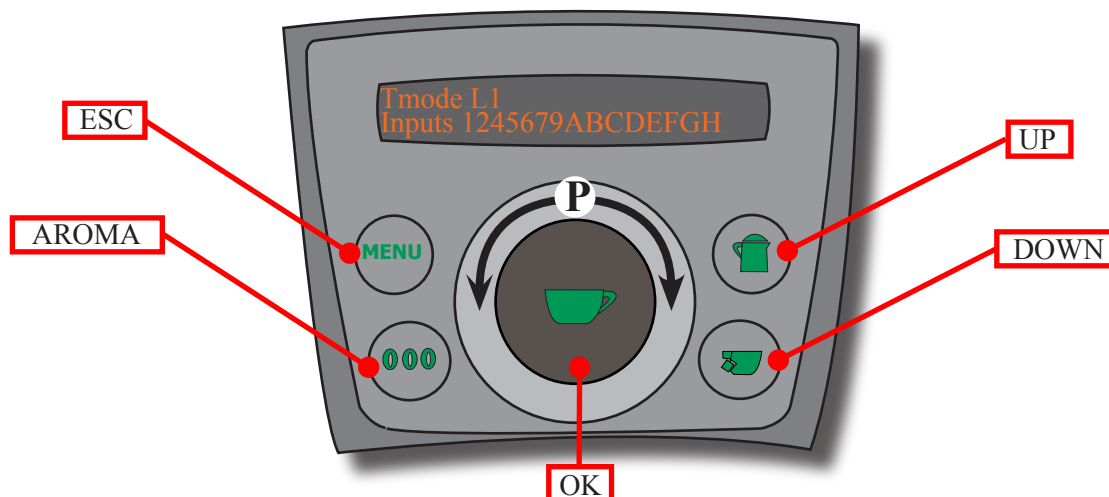

#### Keyboard

##### Key test

MENU	The display indicates no. 1
AROMA	The display indicates no. 2
OK	The display indicates no. 3
UP	The display indicates no. 5 5
DOWN	The display indicates no. 6
UPWARD	The display indicates no. 9 (Motorized tank capacitive key up)
DOWNWARD	The display indicates no. A (Motorized tank capacitive key down)

#### No. 1

##### Microswitch and INPUT - OUTPUT sensor control

- BREWUNIT (unit located) The display indicates no. 1.
- WATERLEVEL (water level detection) The display indicates no. 4.
- BU\_BOOR (close service door) The display indicates no. 5.
- DREGDRAWER (dreg drawer located) The display indicates no. 6.
- DRIPTRAY\_PRES (drip tray located) The display indicates no. 7.
- DRIPTRAY\_LEVEL (drip tray level detection) The display indicates no. 8.
- CUPLIFT\_TOP (Upper Motorized tray limit switch activated). The display indicates C.
- CUPLIFT\_BOTTOM (Lower Motorized tray limit switch activated) The display indicates D.

- CAPP\_DOOR\_CLOSED (milk container door closed) The display indicates E
- CAPP\_DOOR\_CLOSED+CAPP\_PRES (milk container and cappuccinatore door closed)  
The display indicates F
- COFFEE\_BEANS\_DOOR\_CLOSED (coffee container lid closed). The display indicates G
- TANK\_PRES (water tank located). The display indicates H

### **Level 2**

#### **Check gearmotor moving unit**

- PRESS UP (unit up). The display indicates 5 when the upper gearmotor sensor is activated.
- PRESS DOWN (unit down). The display indicates 6 when the lower gearmotor sensor is activated  
Torque absorption is indicated during movement (max 350 mA).

### **Level 3**

#### **Test coffee grinder and pump**

- PRESS ESC KEY (the pump starts). The display indicates turbine pulses.
- PRESS OK KEY (excites milk container solenoid valve)  
The display indicates SOLENOID ACTIVATED and no.3.
- PRESS AROMA KEY (coffee grinder starts)
- PRESS UP OR DOWN KEY (to vary aroma)

### **Level 4**

#### **Test water heater and cup warmer**

- PRESS THE UP KEY (water tank is filled). The display indicates change in temperature.
- PRESS THE ESC KEY (cup warmer is activated). You can feel the cup warmer heating up.

### **Level 5**

#### **Test multivalve.**

- PRESS THE UP KEY (position changed in clockwise direction)
- PRESS THE DOWN KEY (the position changes in anticlockwise direction)
- PRESS ESC KEY (returns to water position)

### **Level 6**

#### **Test cappuccinatore**

- PRESS THE UP KEY (moves to position 0)
- PRESS THE DOWN KEY (moves to position 1)

**Level 7**

**Motorized tray test**

- PRESS UP KEY (lower touch pad) KEY 9
- PRESS DOWN KEY (upper touch pad) KEY A
  - The display indicates D = lower limit position micro
  - The display indicates C = upper limit position micro
  - The display indicates A = upper touch pad
  - The display indicates 9 = lower touch pad

**Level 8**

**Display contrast test**

- PRESS UP KEY (increase contrast)
- PRESS DOWN KEY (reduce contrast)

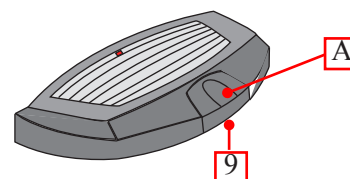

**Level 9**

**Display backlighting test**

- PRESS UP KEY (increase intensity)
- PRESS DOWN KEY (reduce intensity)

**Level B**

**This procedure restores the default parameters of the appliance with the exception of:**

- Coffees made since production counter.
- Errors since production counter.
- Descaling solution used.
- Water since last descaling, from last to second last, from second to third last, from third last to fourth last.
- Number of descalings performed.
- Number of clean cycles run on unit.
- Number of times unit has been removed.
- Seconds counter for total time machine switched on.

**Level C**

**Language test**

- PRESS UP OR DOWN KEY (select the sequence of messages in each language)
- PRESS OK KEY (select language)

**LEVEL D**

**Test steamout**

- PRESS OK KEY (prepares appliance for packaging)
  - Empties water circuit and raises motorized tray.

**LEVEL E**

- EXIT

## 5.4 Ring diagnosis function

Procedure for access to diagnostics mode.

Turn the appliance off and then on again or exit standby mode to enter the diagnostics menu, according to the sequence shown in the figure.

For access to the diagnostics menu, there is a timeout limit of 3 sec. between one selection and the next.(1,2,3,4)

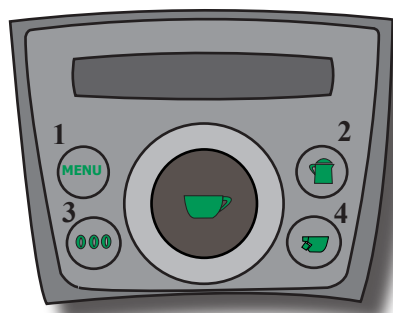
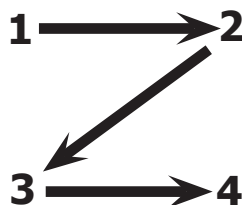

A window is displayed showing the following options:

- Product counters
- Total counters
- Error counters
- Product settings
- System settings
- Exit diagnostics menu

Description of options available

### 5.4.1 Beverage counters

Total espresso coffees

1.1.1 Total beverages

not modifiable

1.1.2 Water used (ml.)

not modifiable

1.2 Total coffee beverages

1.2.1 Total beverages

not modifiable

1.2.2 Water used (ml.)

not modifiable

1.30 Total long coffee beverages

1.3.1 Total beverages

not modifiable

1.3.2 Water used (ml.)

not modifiable

1.4 Total latte macchiato beverages

1.4.1 Total beverages

not modifiable

1.4.2 Water used (ml.)

not modifiable

1.5 Total cappuccino beverages

1.5.1 Total beverages

not modifiable

1.5.2 Water used (ml.)

not modifiable

1.6 Total espresso macchiato beverages

1.6.1 Total beverages

not modifiable

1.6.2 Water used (ml.)

not modifiable

1.7 Total hot milk beverages

1.7.1 Total beverages

not modifiable

1.7.2 Dispense time (sec.)

not modifiable

1.8 Total hot water beverages

1.8.1 Total beverages

not modifiable

1.8.2 Water used (ml.)

not modifiable

- 1.9 Total beverages (all) not modifiable
- 1.10 Total descaler used (ml) not modifiable

### 5.4.2 Total counters

- 2.1 Water used since production (ml.) not modifiable
- 2.2 Water used since last descaling (ml.) not modifiable
- 2.3 Water used since second last descaling (ml.) not modifiable
- 2.4 Water used since third from last descaling (ml.) not modifiable
- 2.5 Number of descalings (cycles) not modifiable
- 2.6 Number of brew group cleaning cycles not modifiable
- 2.7 Number of cappuccinatore cleaning cycles not modifiable
- 2.8 Number of brew group removals (cycles) not modifiable
- 2.9 Machine active time (sec.) not modifiable

### 5.3.4 Error counters (access submenu)

The appliance records the following errors

- 3.1) Coffee grinder 1 blocked
- 3.3) Brew group blocked; up command (Work)
- 3.4) Brew group blocked; down command (Home)
- 3.5) Water circuit blocked
- 3.6) Multivalve error
- 3.8) Cappuccino valve blocked
- 3.10) Water heater sensor disconnected
- 3.11) Water heater sensor shorted
- 3.14) Water heater temperature error
- 3.16) Both microswitches activated on brew group
- 3.17) Memory error
- 3.18) Clock error
- 3.19) No zero crossing
- 3.20) Cuplift error (motorized tray)

All these errors display the following submenu

- Production errors not modifiable
- Errors since last service resettable - modifiable

3.21) Error history: the last 20 errors are saved and coded from 3.21.1 to 3.21.20

### 5.4.4 Ring product settings

BEVERAGE SETTING parameters	Unit of measurement	Settings range	Default value
<b>4.1 ESPRESSO</b>			
4.1.1 Temperature		low, high, medium	medium
4.1.2 Aroma		medium, light, pre-ground, strong	forte
4.1.3 WATER	turb. pulses.	70 ... 450	STD 165 IT 110
<b>4.2 COFFEE</b>			
4.2.1 Temperature		low, high, medium	medium
4.2.2 Aroma		medium, light, pre-ground, strong	medium
4.2.3 WATER	turb. pulses.	70 ... 450	STD 280 IT 200
<b>4.3 LONG COFFEE</b>			
4.3.1 Temperature		low, high, medium	medium
4.3.2 Aroma		medium, light, pre-ground, strong	medium
4.3.3 WATER	turb. pulses.	70 ... 450	STD 440 IT 330
<b>4.4 ESPRESSO MACCHIATO</b>			
4.4.1 Temperature		low, high, medium	medium
4.4.2 Aroma		medium, light, pre-ground, strong	medium
4.4.3 WATER	turb. pulses.	70 ... 450	STD 165 IT 110
4.4.4 Milk time	seconds	2 ... 50	STD 11 IT 6
<b>4.5 LATTE MACCHIATO</b>			
4.5.1 Temperature		low, high, medium	medium
4.5.2 Aroma		medium, light, pre-ground, strong	medium
4.5.3 WATER	turb. pulses.	70 ... 450	STD 280 IT 200
4.5.4 Milk time	seconds	2 ... 50	20
<b>4.6 CAPPUCCINO</b>			
4.6.1 Temperature		low, high, medium	medium
4.6.2 Aroma		medium, light, pre-ground, strong	medium
4.6.3 WATER	turb. pulses.	70 ... 450	STD 280 IT 200
4.6.4 Milk time	seconds	2 ... 50	18
<b>4.7 HOT MILK</b>			
4.7.1 Milk time	seconds	2 ... 50	24
<b>4.8 HOT WATER</b>			
4.8.1 Water	turb. pulses.	70 ... 450	330

### 5.4.5 Ring system settings

SYSTEM SETTING parameters	Unit of measurement	Settings range	Default value
<b>SETTING</b>			
Water heater temperature enabled	°C	70 ... 150	130
Water heater temperature disabled	°C	70 ... 150	115
Steam heater temperature enabled	°C	70 ... 150	150
Steam heater temperature disabled	°C	70 ... 150	130
Normal cup temperature	°C	70 ... 150	78
<b>PRODUCT PARAMETERS</b>			
Hot water	flow rate (l/h)	5 ... 31	18
Hot milk (pulse length)	line-period	1 ... 3	6 (=120ms/50Hz)
Hot milk (pulse period)	20ms - steps	5 ... 250	60 (=1200ms)
<b>MILK CIRCUIT RINSE</b>			
Distribution time	seconds	0 ... 40	10
Pulse length	line-period	1 ... 3	1 (= 20ms / 50Hz)
Pulse period	20ms - steps	5 ... 250	15 (=300ms)
<b>MILK CIRCUIT CLEANING</b>			
Milk circuit cleaning (distribution time)		0 ... 40	10
<b>MILK CIRCUIT CLEANING MESSAGES</b>			
Cleaning time	seconds		30
Days till message	giorni		14
Days till block	days		21
<b>STOP COFFEE GROUNDS</b>			
Stop coffee grounds	no. grounds	0 ... 25	24
Coffee dregs counter	no. grounds	0 ... 25	24
Water reserve limit	turbine pulses	0 ... 2000	750
Serial number			
Stand - by (energy saving)	hours / minutes	0-3 / 0-59	3



### 5.5.3 Error messages for Service personnel

Code	Applicable models: Primea-Odea-Talea	Brief description	Description
01	All	Coffee grinder 1 blocked.	The coffee grinder is blocked (grinders blocked or sensor not reading properly).
02	Primea	Coffee grinder 2 blocked.	The coffee grinder is blocked (grinders blocked or sensor not reading properly).
03	All	Brew group blocked in work position.	Microswitch not released in up position after 3", torque error trying to move down, descent time out exceeded.
04	All	Brew group blocked in home position.	Microswitch not released in down position after 3", torque error trying to move up, ascent time out exceeded.
05	All	Water circuit blocked.	No water in turbine.
06	Primea	Multivalve error.	Multivalve blocked.
08	Primea	Cappuccino valve blocked.	The cappuccinatore has failed to reset because it can't excite microswitch.
09	Primea	Communication error between CPU and POWER.	Communication interrupted for more than 2 seconds.
10-11	All	Various sensor errors.	Water heater sensors shorted or in open circuit.
12-13	Primea	Various sensor errors.	Steam heater sensors shorted or in open circuit.
14-15	All	Various temperature errors.	Heater temperatures out of limit.
16	All	Both microswitches activated on brew group.	The work microswitch and home switch have both been activated..
17	All	Memory error.	Impossible to read or write to e2prom.
18	All	Clock error.	Memory defect or impossible to set.
19	All	No zero crossing.	No zero crossing on card, could be caused by power card.
20	All	Cuplift error.	The two stroke end position microswitches are activated at the same time.

On models in the new Primea, Talea and Odea ranges, errors recorded can be viewed on the display (during diagnosis) or on a PC (with programmer). The following are saved:

- A) The last 20 errors to be recorded.
- B) Total number of errors (not all models)
  - since production (total)
  - since last service (partial)
  - current

## 6.5 Problems, causes, remedies

HELP MESSAGES DISPLAYED	HOW TO RESET MESSAGE
Turn the appliance off and on to solve the problem	Switch off and after 30 sec. turn on the appliance to restore normal operating conditions.
Call the Service Center	Problem requiring assistance of Service Center.
Insert drip tray	Insert drip tray.
Close coffee container cover	Close the coffee container to enable delivery of any beverage.
Insert ground coffee	This message guides you when this type of coffee has been selected during custom programming of products.
Insert brew group	Insert brew group in seat.
Insert coffee grounds drawer	Insert coffee grounds drawer.
Empty coffee grounds drawer	Remove coffee grounds drawer and empty. NOTE: The dreg drawer must only be emptied when the appliance is switched on. The drawer must be removed for at least 5 seconds. If the drawer is emptied when the appliance is switched off the message is not reset.
Close side door	Close service door.
Fill water tank	Fill tank.
Empty drip tray below brew group	Empty drip tray.
Insert milk container	Insert tank in milk container.
Prime circuit	Start automatic loading of water circuit. The appliance will automatically try to load the circuit 5 times; if this fails, contact the service centre.
The descaling cycle has not been run correctly	Repeat the operation as described in the relative chapter in the instruction booklet.
Replace prima water filter	This message is only displayed if the filter control is enabled (see instruction booklet). The filter must be replaced if: 1) 60 litres of water have been delivered. 2) 90 days have passed since installation. 3) 20 days have passed since last use of coffee maker.
The cleaning cycle has not been run correctly	Repeat the operation as described in the relative chapter in the instruction booklet.
Insert cappuccinatore	Insert cappuccinatore in milk container.
Rinse milk container	Clean tank after use.
Descale the appliance	Run descaling cycle.
Standby	Press "start".

# ***SECTION 6***

# ***OPERATING***

# ***LOGIC***

**REV.01**

### 6.1 Multi-way valve

#### Touch Plus multi-way valve opening operating diagram

Two factors combine to give the five phases of the multiway valve:  
 1) Activation (or not) of two microswitches on the multivalve  
 2) Direction of rotation of the multivalve<sup>Heater 1</sup>

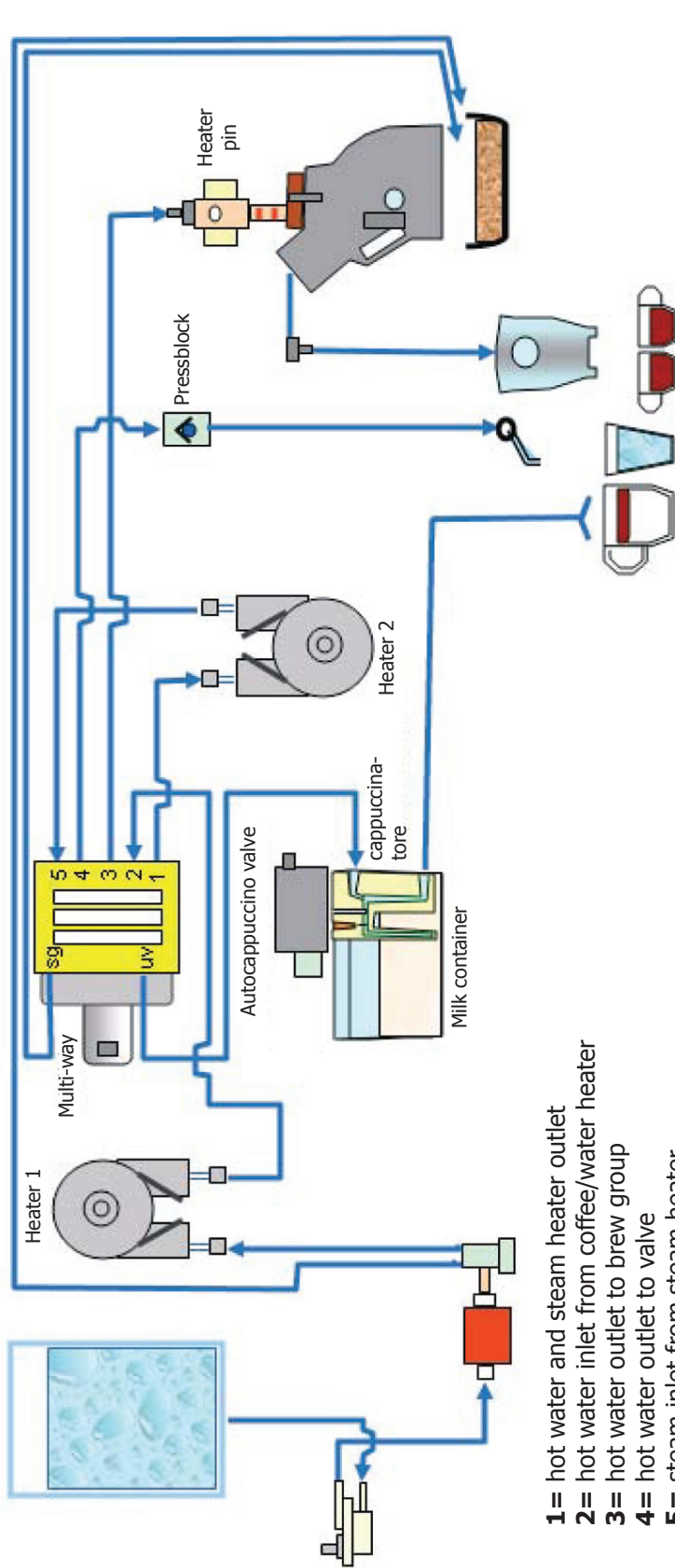

- 1 = hot water and steam heater outlet
- 2 = hot water inlet from coffee/water heater
- 3 = hot water outlet to brew group
- 4 = hot water outlet to valve
- 5 = steam inlet from steam heater
- uv = steam outlet to cappuccinatore
- sg = unit water drain

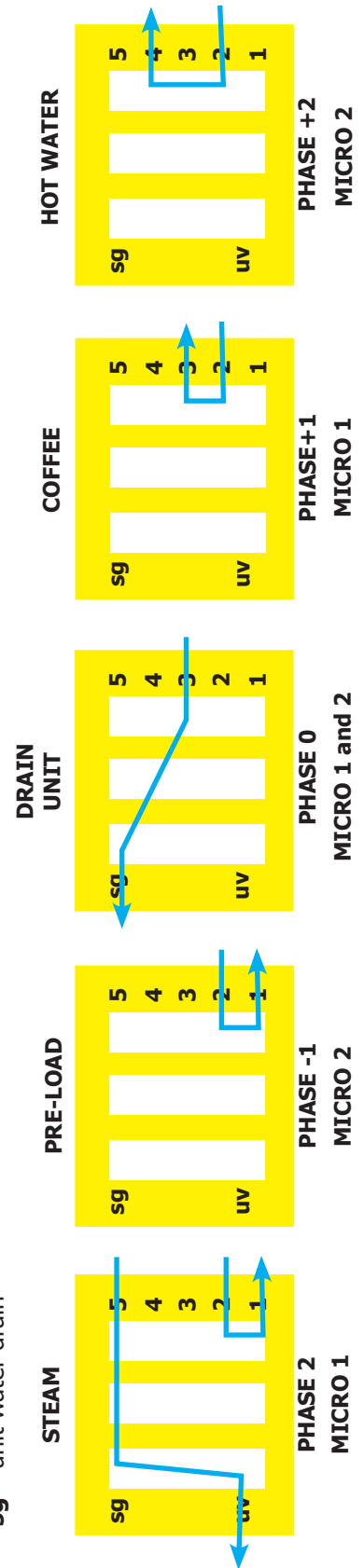

### Ring and Touch multi-way valve opening operating diagram

Two factors combine to give the five phases of the multiway valve:  
 1) Activation (or not) of two microswitches on the multivalve  
 2) Direction of rotation of the multivalve

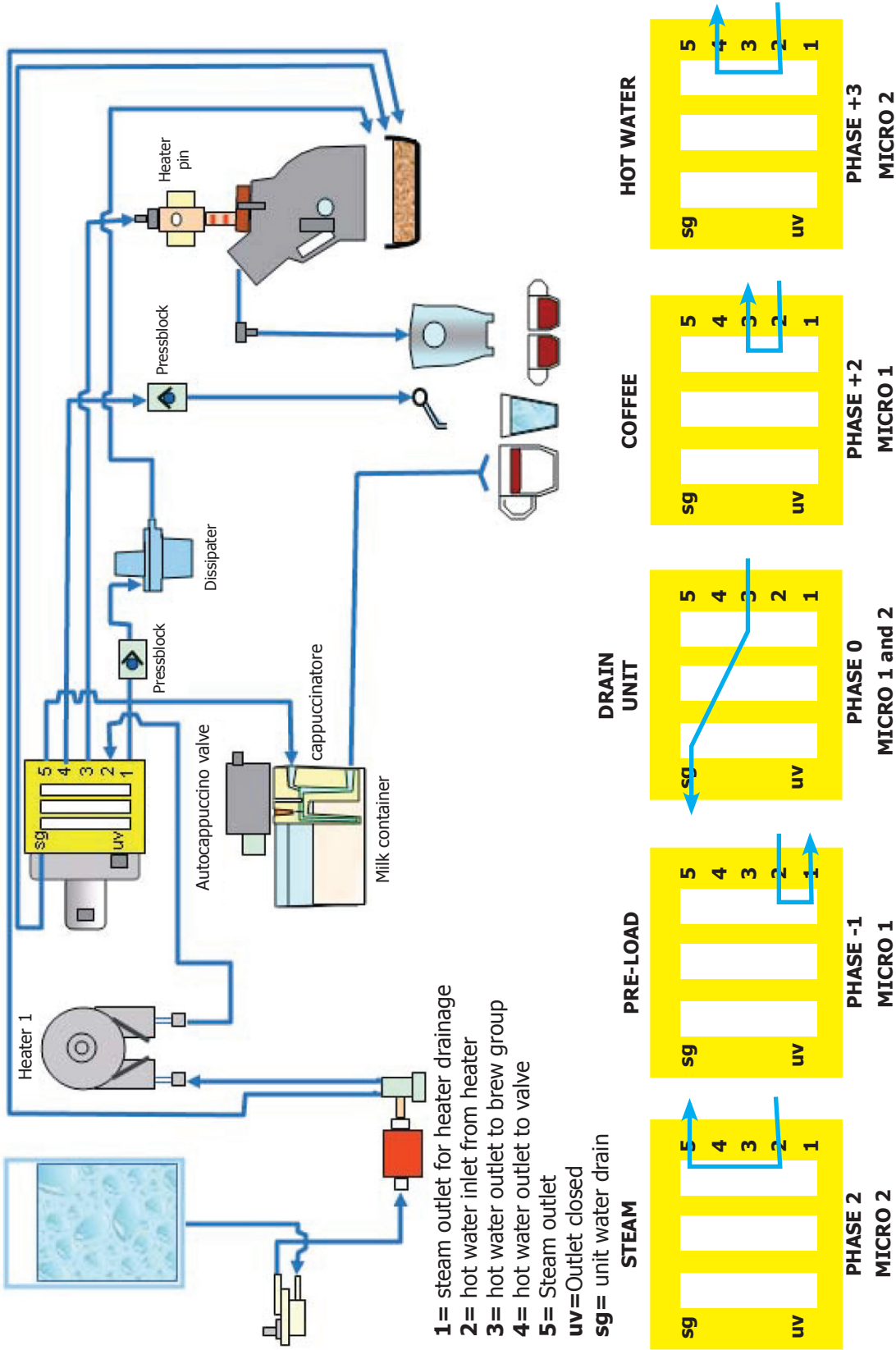

#### HEATER DRAIN

After steam production (e.g: cappuccino) the heater drain enables discharge of the steam into the drip tray with cooling via the dissipater.  
 The heater is re-loaded to enable coffee or water to be dispensed

## 6.2 Auto cappuccino

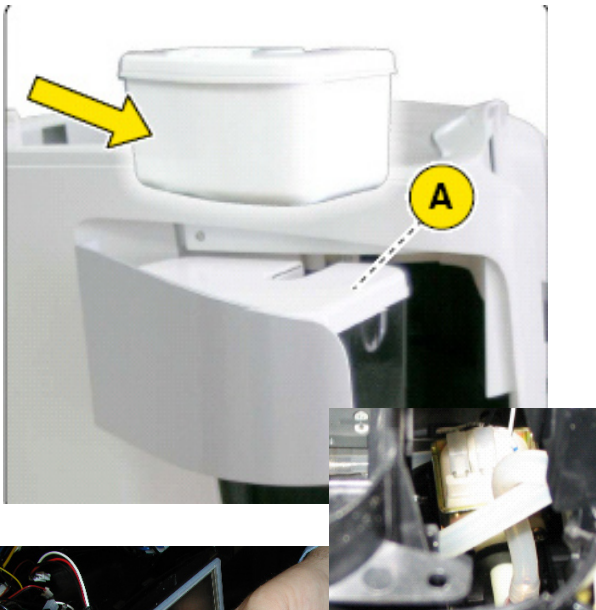

The auto cappuccino system enables the automatic preparation of cappuccino, latte macchiato, caffè macchiato and hot milk.

The milk container (A), with a capacity of approx. 0.4 l. is removable to enable storage of the contents in the fridge when not used.

At the time of cappuccino preparation, the milk is collected directly from the milk container (A), frothed by the action of the steam and delivered to the relative dispenser.

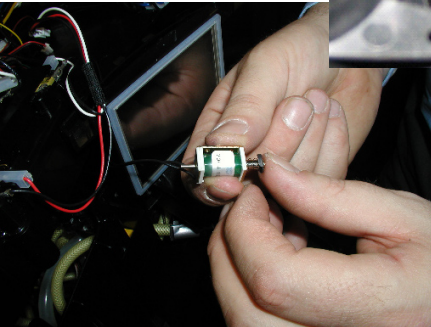

To guarantee positioning of the milk hatch, an electromagnet locks the door on selection of a product with milk.

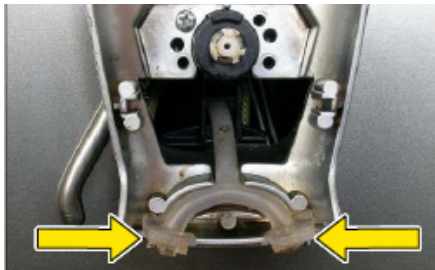

The holes that deliver the milk enable simultaneous preparation of two cappuccinos.

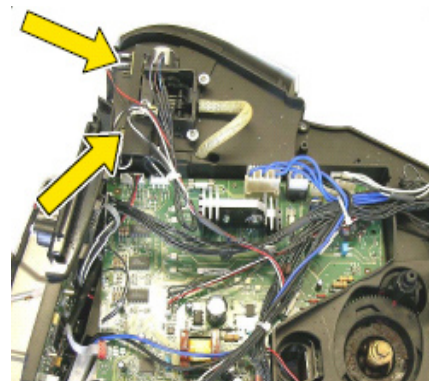

Two microswitches, when activated, indicate:

1. Closure of the milk container
2. Presence of milk container.

After a milk-based beverage is dispensed, a circuit rinse is proposed.  
(if it is not rinsed within 20 minutes, the appliance blocks all milk-based beverages).

If no milk-based beverages have been delivered over the past 14 days, the appliance will request the milk circuit to be cleaned with a cleaning tablet.  
(if it is not done within 21 days, all milk-based beverages are blocked).

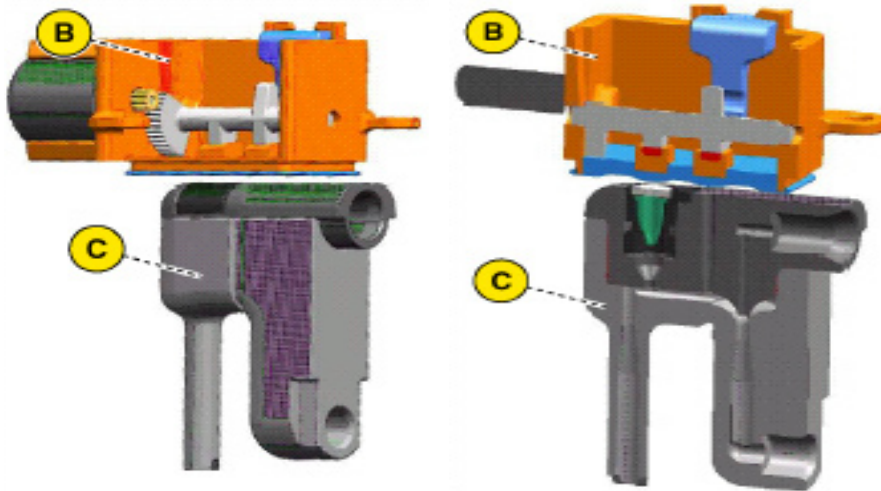

The system consists of a motorized valve (B), which controls air required to froth milk along with the “Vernay” valve and aeration/drainage of milk, and a cappuccinatore (C).

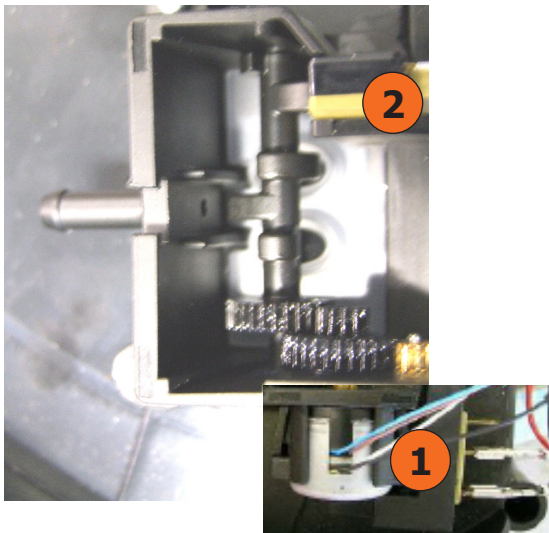

The motor (1) is a stepper version and the internal microswitch (2) which resets the position after dispensing.

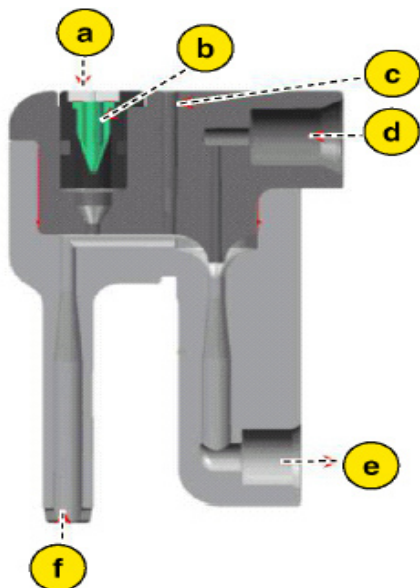

Cappuccinatore layout  
 a - Air inlet for frothing  
 b - Vernay valve  
 c - Milk aeration/drainage  
 d - Steam inlet  
 e - Milk outlet  
 f - Milk inlet

## Cappuccinatore positions and functions

The stepper motor has three positions:

- INIT (REPOSITIONING)
- FOAM (MILK FROTH)
- MILK D. (MILK DRAIN)

**POSITION 1  
INIT  
(REPOSITIONING)**

**POSITION 2  
FOAM  
(MILK FROTH)**

**POSITION 3  
MILK DRAINAGE  
(MILK DRAIN)**

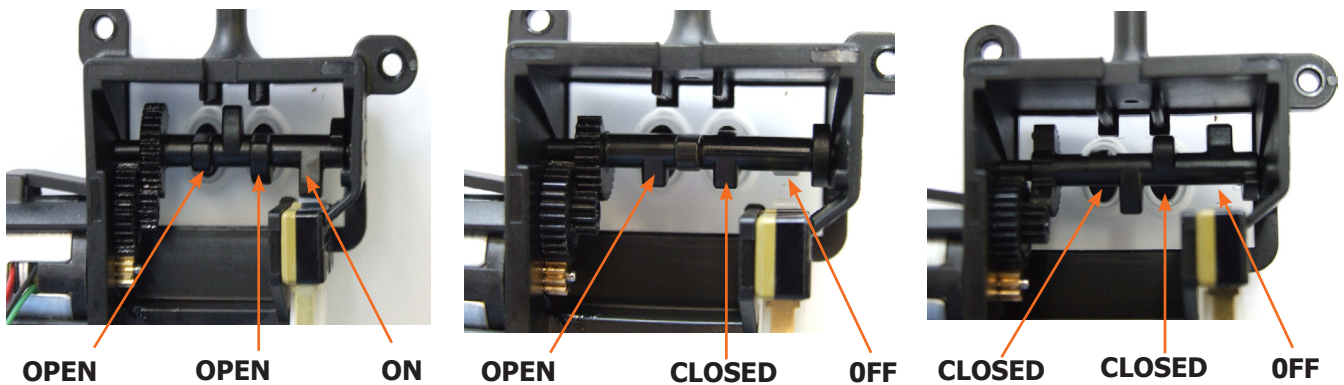

POSITIONS	Position 1 INIT	Position 2 FOAM	Position 3 MILK DRAINAGE
AIR INLET (VERNAY)	OPEN	OPEN	CLOSED
MILK DRAIN	OPEN	CLOSED	CLOSED
MICRO	ON	OFF	OFF

### Beverage preparation sequence

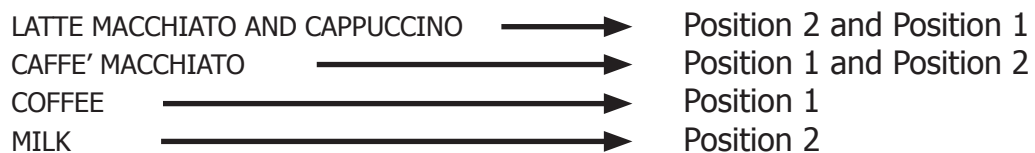

The circuit pressure is discharged after each beverage dispensed.



### 6.3 Motorized tank

The movement of the motorized tank is mechanical by means of a stepper motor (1) in 24V DC, controlled by two capacitive pushbuttons (2) located at the front of the tank. The two microswitches (3) are for the limit switch, and operation can be checked in test mode (see para. 5.1)

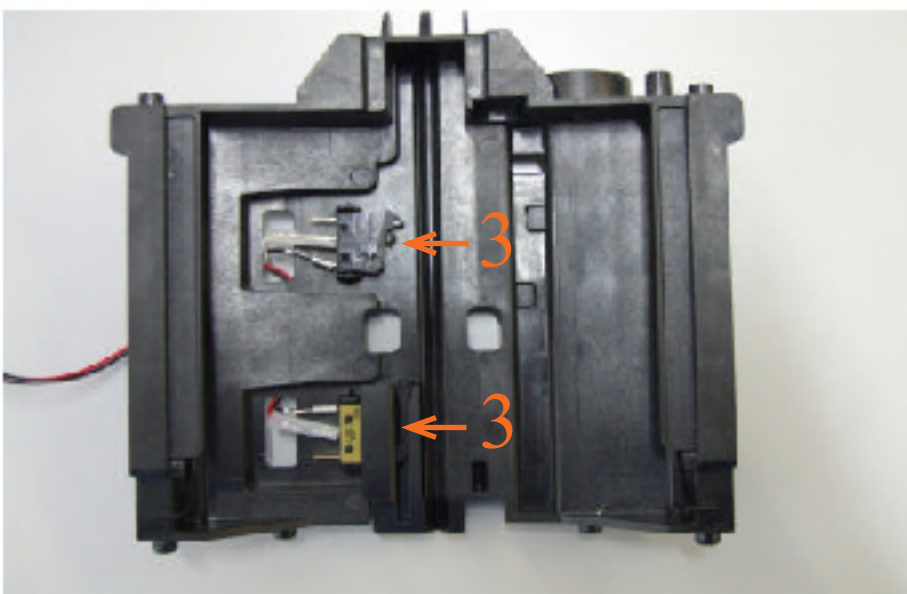
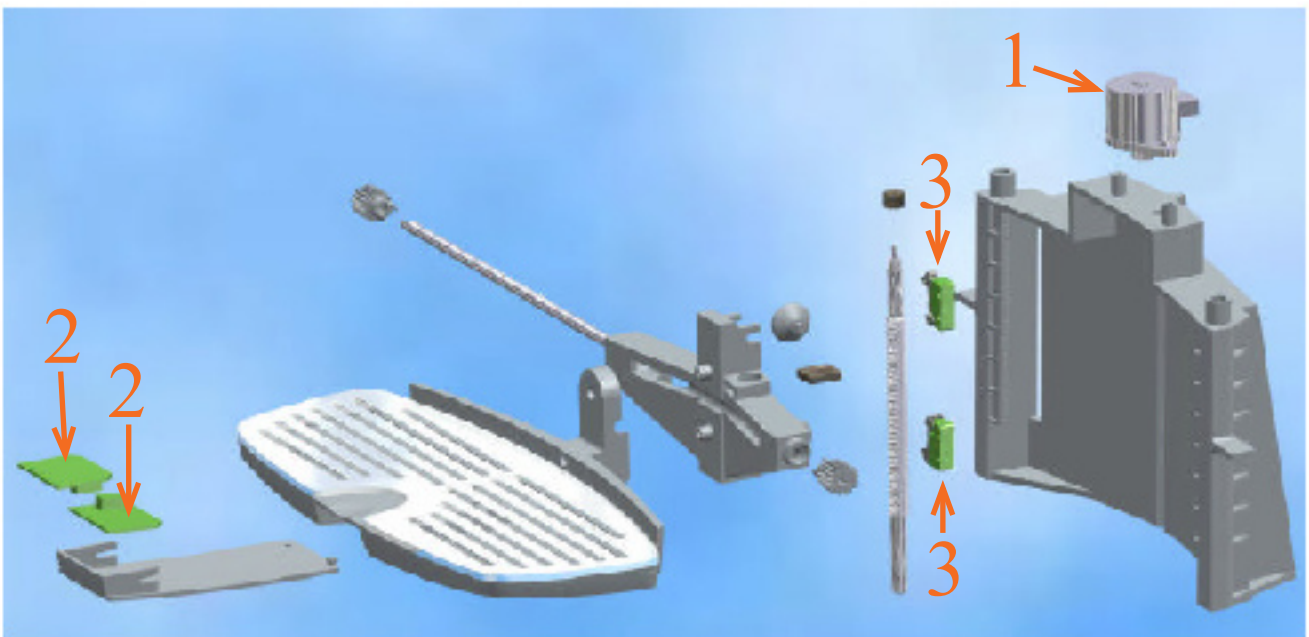

## 6.4 Aqua Prima

### Operating logic with "AQUA PRIMA" filter

When use of the "aqua prima" filter is selected on the user menu or via the control panel, the system water count logic is as follows:

If the "aqua prima" function is **enabled** the electronics perform a pulse count of the turbine, recording **one pulse every 2 revolutions**.

If the "aqua prima" function is **disabled**, the electronics perform a pulse count of the turbine, recording **one pulse every revolution**.

The figure below provides a graph, illustrating this function:

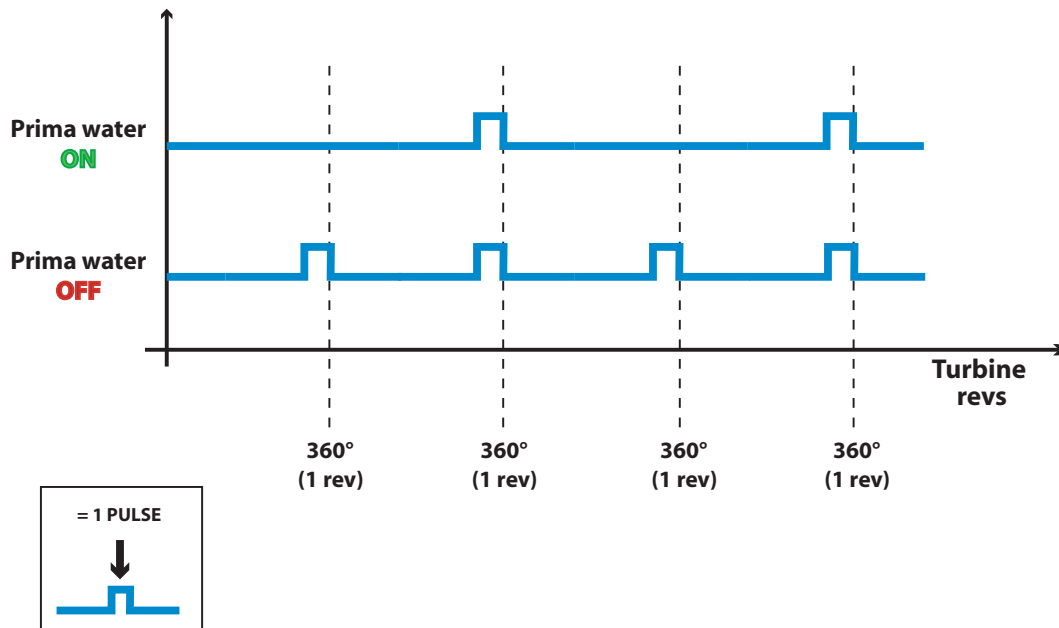

## 6.5 SBS Valve

### Beverage dispensing process

The SBS dispense valve SBS (see fig. 2) controllable via the knob, enables variation (increasing or decreasing according to the position of the knob) of the water flow rate for brewing. This adjusts the coffee brewing time (extraction time) and consequently the intensity of taste, keeping the cream quality constant.

### Function

With the SBS valve in the open position, coffee is accumulated in the membrane valve due to a low back-pressure of the SBS valve. Consequently the membrane valve needle remains in the maximum open position, due to resistance of the spring. Coffee exits quickly (see fig. 3).  
 With the SBS valve in the closed position, coffee is accumulated on the membrane of the valve with a consequent increase in pressure in the valve. The spring yields to the back-pressure and the needle then reduces the coffee passage (see fig. 4).

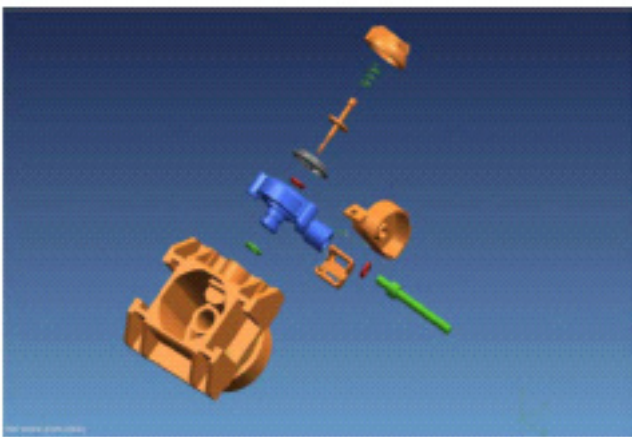

Fig.1

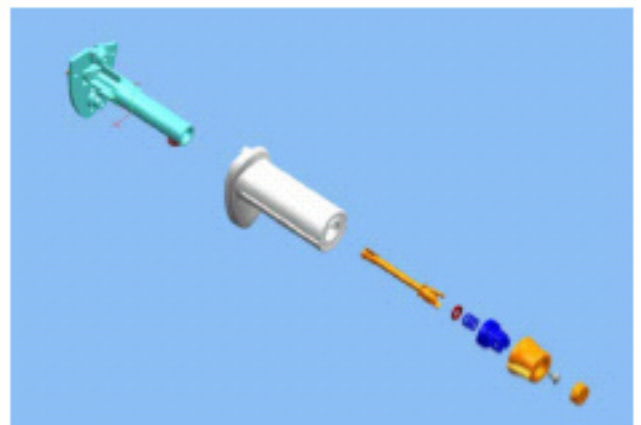

Fig.2

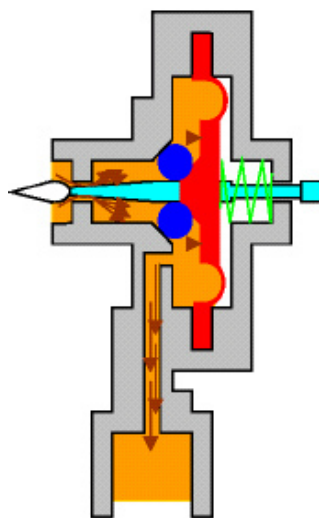

Fig.3

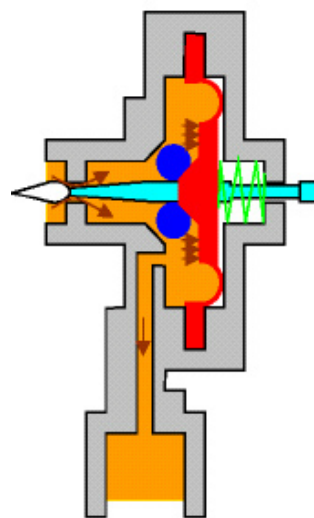
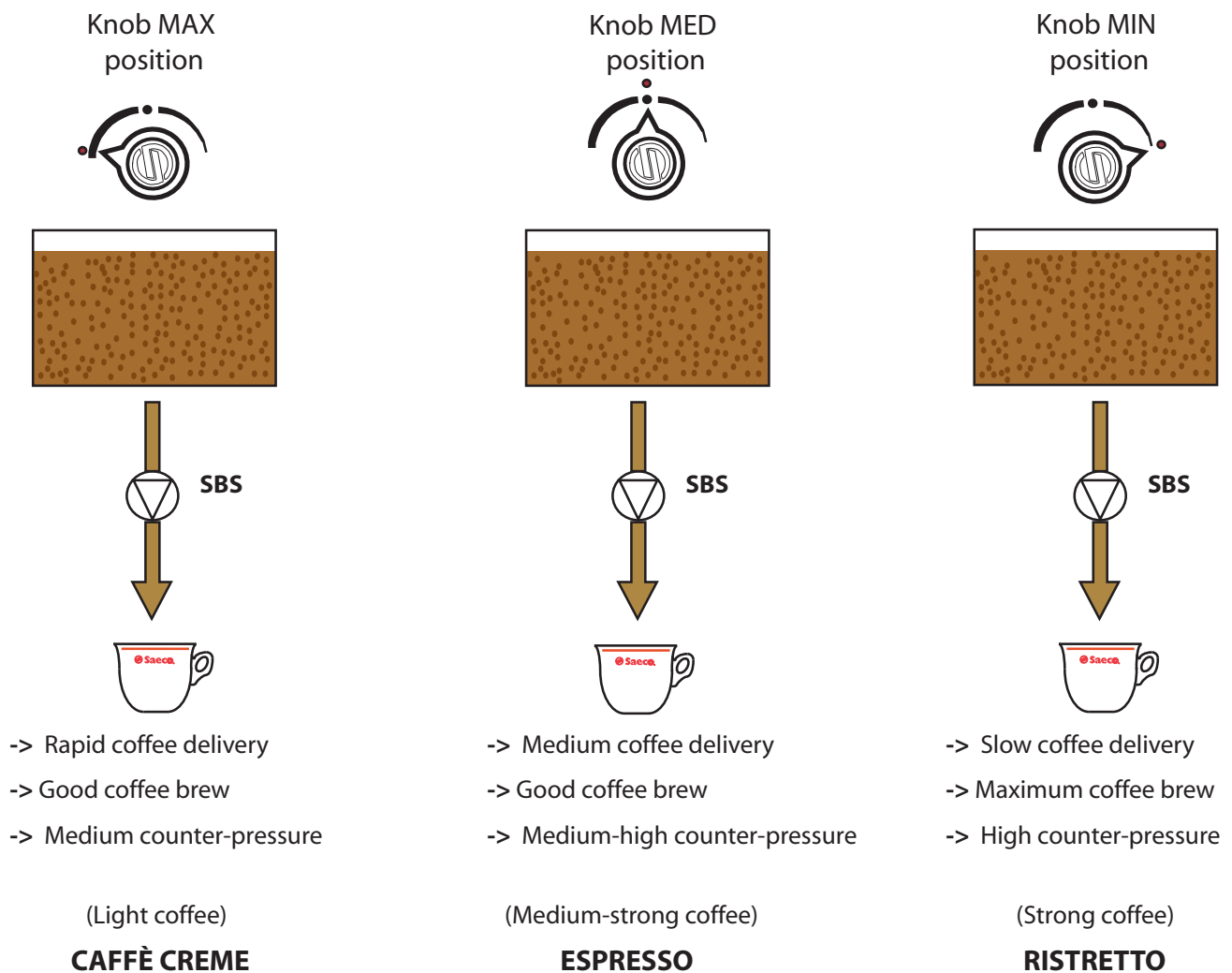

Fig.4

## SBS valve operation check

To ensure correct operation of the valve SBS, a long coffee should be made. During preparation of the latter, check the difference in dispensing speed between the maximum and minimum positions.

**The difference in dispensing speed is approx. 2.5 times greater (and therefore VERY obvious!!)**



***SECTION 7***  
***COMPONENT***  
***ASSEMBLY AND***  
***DISASSEMBLY***

**REV.01**

## 7.1 Top cover

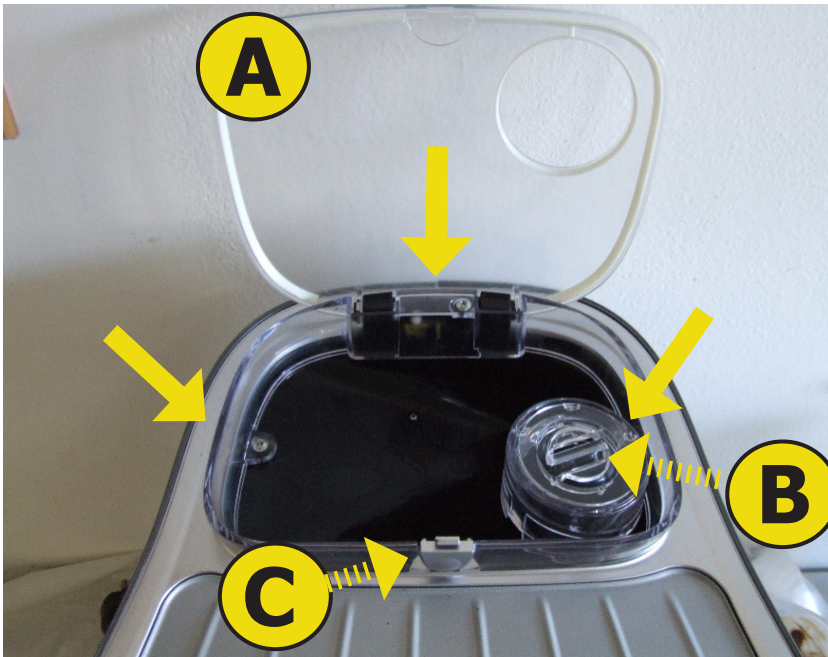

Open cover (A).  
 Remove any coffee beans (B).  
 Extract the cover closure rebate (C).  
 Loosen the three fixing screws of the bean hopper and remove from unit.

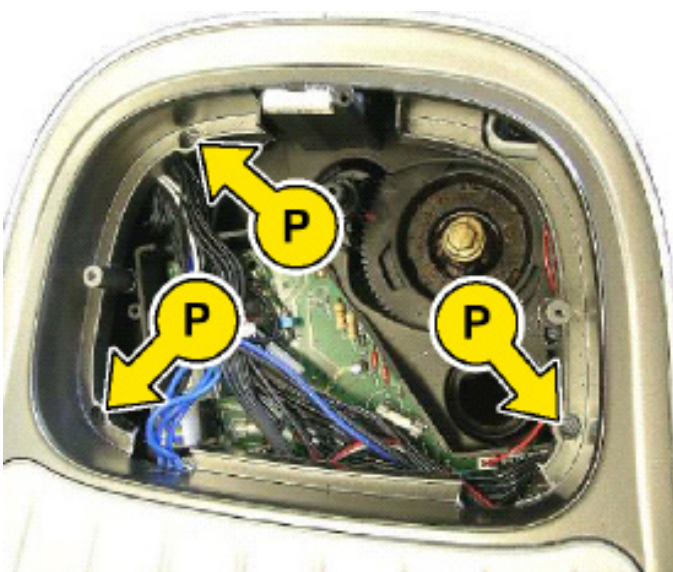

Release the end section of the top cover by loosening the three screws (P).

## 7.2 Right side cover

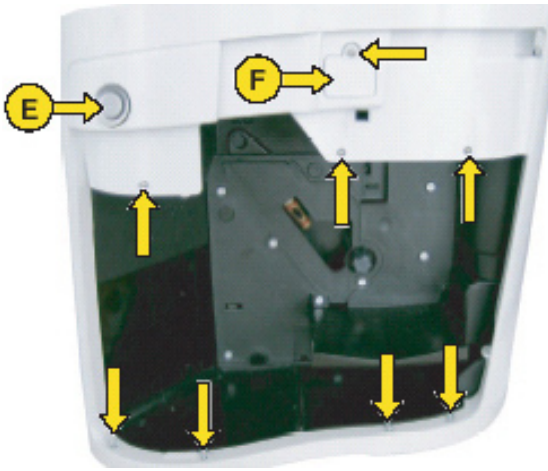

Move the dispensing drip tray to the lower limit position.  
 Disassemble the start push button (E).  
 Remove the door (F) protecting the connection socket of the setting device, by means of a Phillips screwdriver.  
 Remove the screws as indicated.



Raise the rear section of the top cover slightly

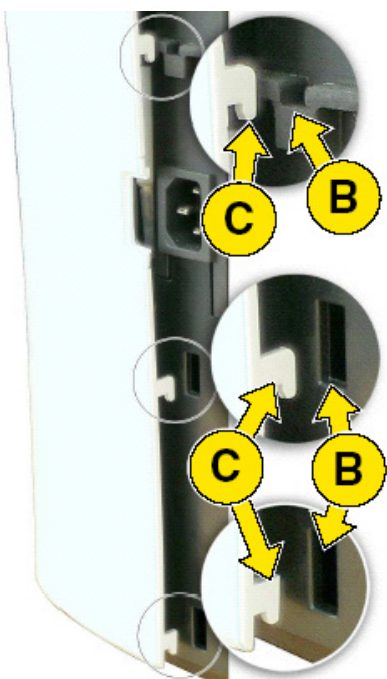

Push the upper section of the right side cover upwards to release from hooks (C) from slots (B).  
 To facilitate release, push the front section of the cover downwards.

### 7.3 Left side cover

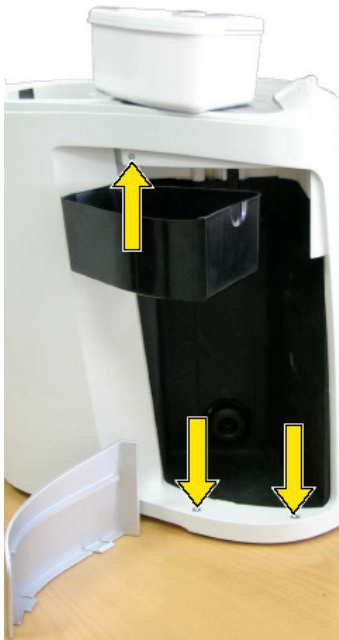

Remove the screws as indicated.



Raise the rear section of the top cover slightly.

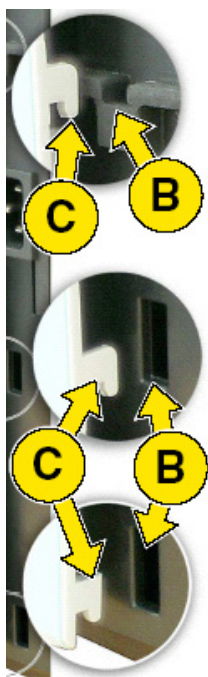

Push the upper section of the left side cover upwards to release from hooks (C) from slots (B).  
To facilitate release, push the front section of the cover downwards.



### 7.4 Brew group



Remove the knob with the Saeco logo by pulling outwards.



Remove the center screw and knob mount with a #1 Phillips head screwdriver.

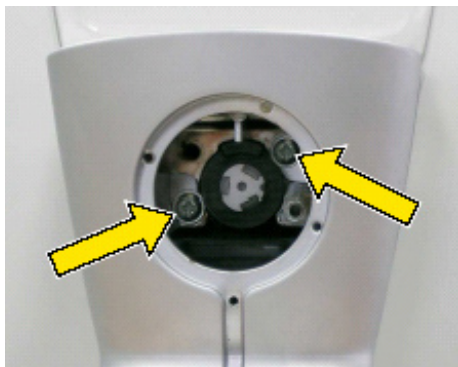

Remove 2 screws securing dispensing head cover.



Remove the dispensing head cover.

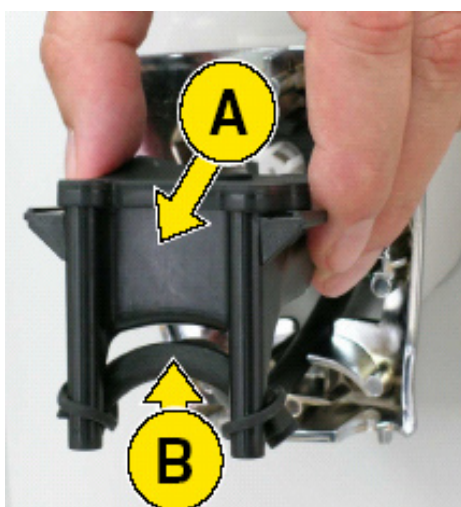

Slide the dispensing body (A) out bringing with it the milk dispensing hose (B)

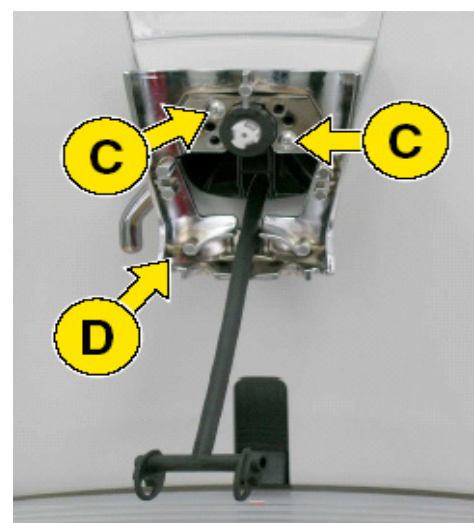

Remove the two screws (C) and remove the rear dispenser body (D).

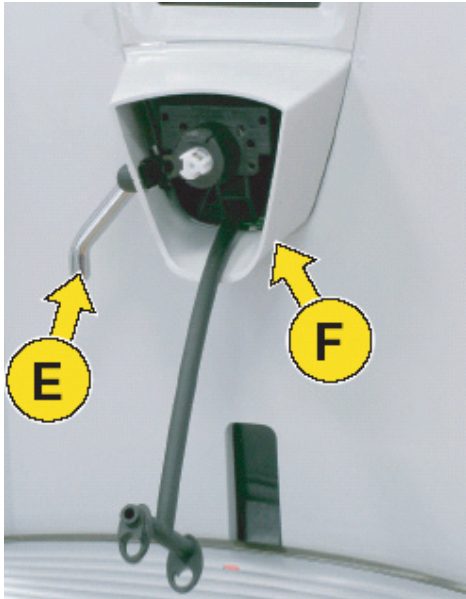

Remove dispensing head spacer (F) and then hot water spout (E) from the spacer.

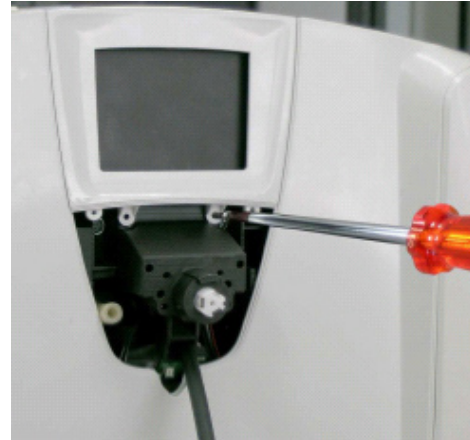

Remove the two screws securing the display molding.



Remove the two screws securing the front cover.

**Assembly:**  
to assemble, follow the above sequence in reverse order.

## 7.5 Electronics

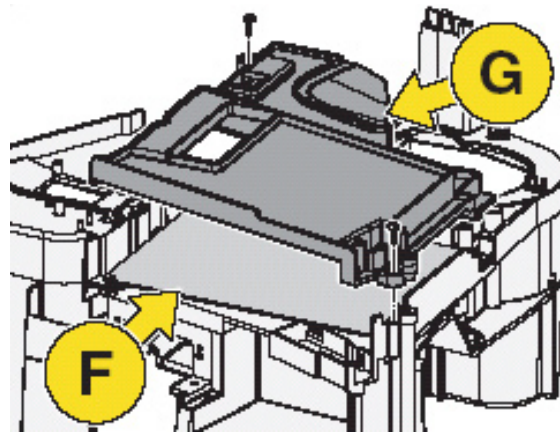

To access board (F) remove the board protection screws (G) does not point at screws.

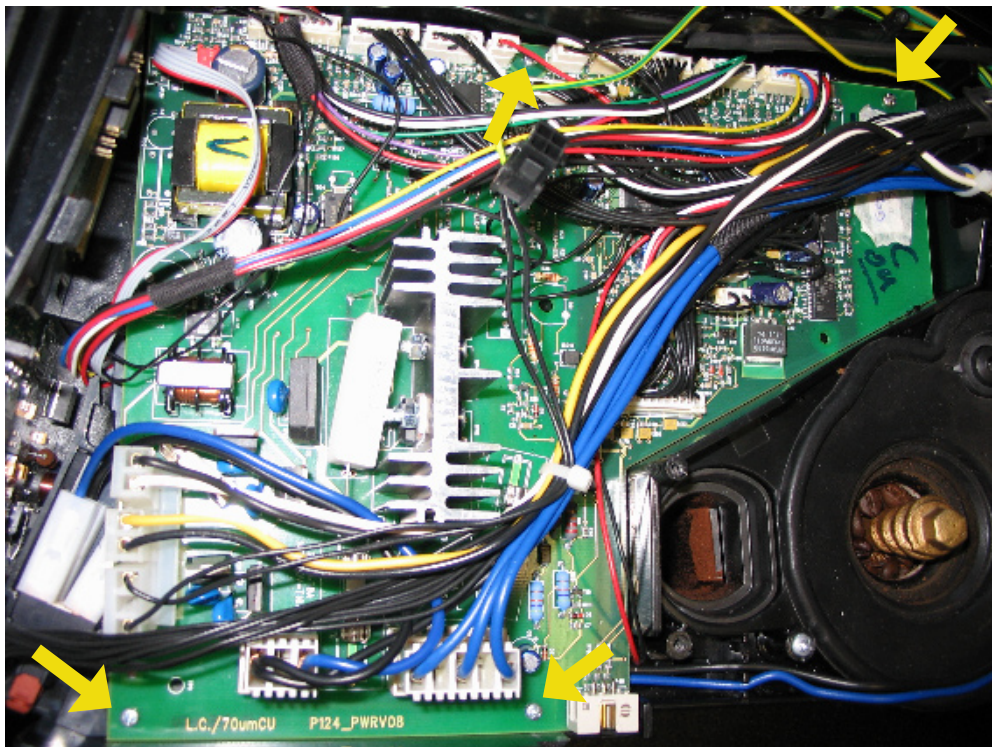

Remove the screws as indicated, remove and label all connectors.

## 7.6 Gearmotor

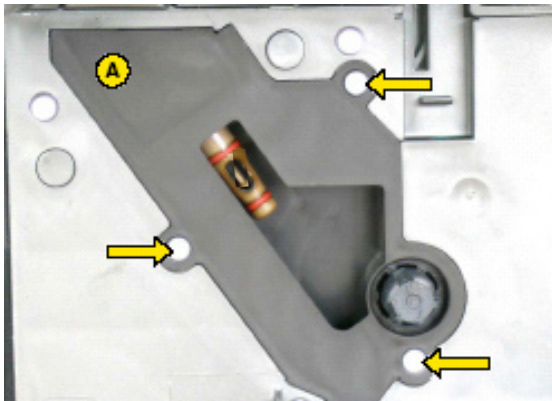

Remove the casing (A) by loosening the three screws.

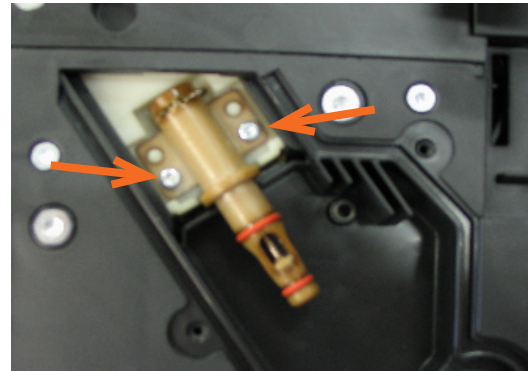

Remove the two screws and remove the heater valve asm. (B).

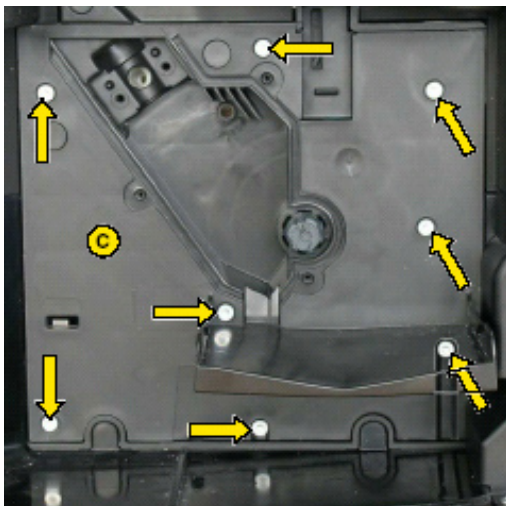

Disassemble the protection plate (C) by removing the screws.

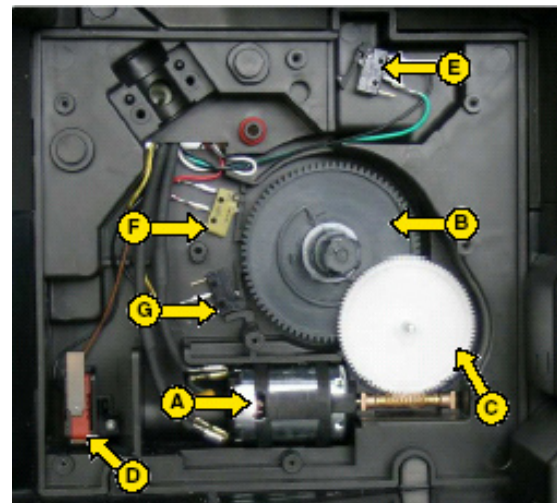

The following are located inside the compartment protected by the casing:

- electric motor (A) with gears (B) and (C) for transmission and timing of the brew group;
- coffee grounds drawer present microswitch (D);
- Brew group present microswitch (E);
- microswitch (F) brew group at home position;
- microswitch (G) brew group at brew position.

Withdraw the gear (C) that meshes with the motor transmission shaft.

Withdraw the large gear (B).

Pull out the motor (A) complete with transmission shaft (H).

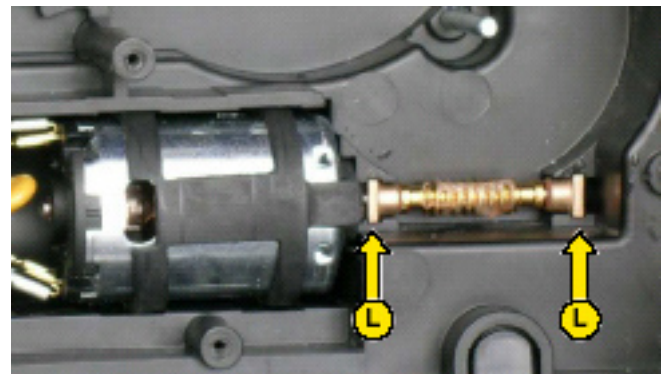
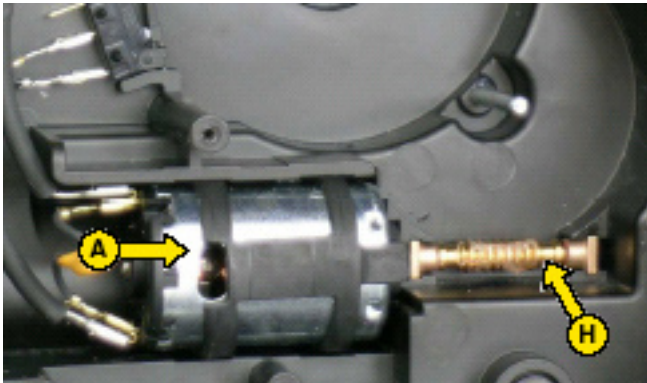

Install the motor and transmission shaft, inserting the guides (L) in the relative seat

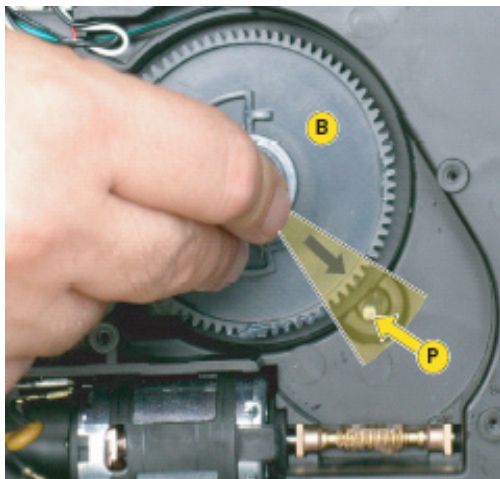

Insert the gear (B), taking care that the arrow stamped on the element is within the opening that contains pin (P).

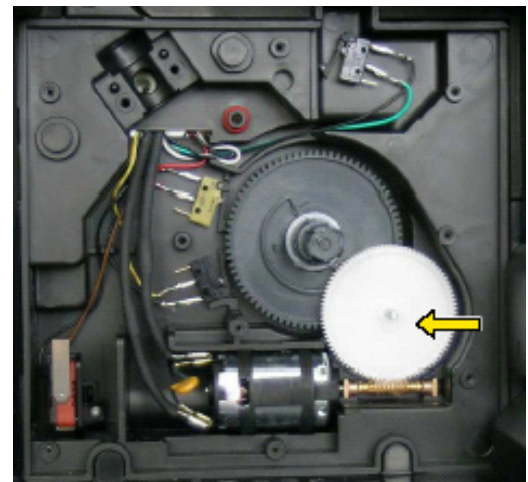

Insert the gear so that it meshes with the transmission shaft.

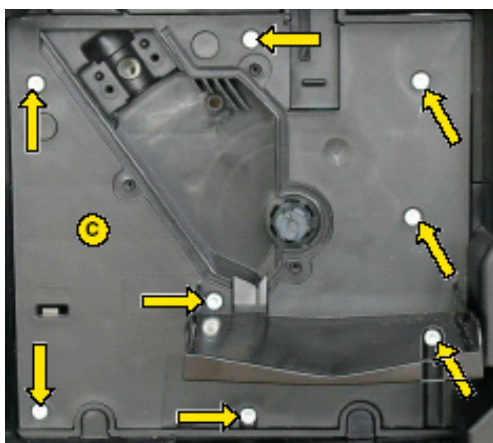

Refit the protection casing (C) and tighten the screws

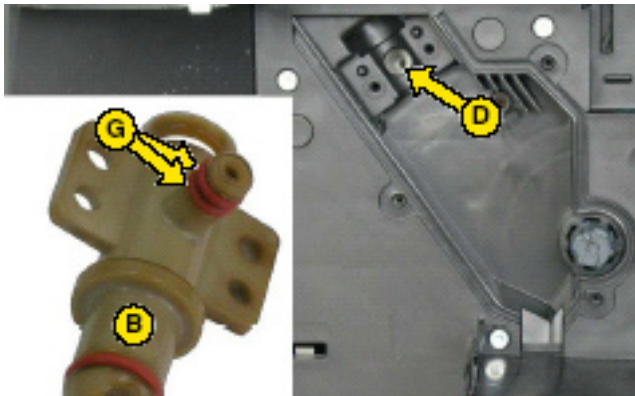

Refit the heater valve asm. (B) taking care to ensure that both seals (G) are present on the spout that is inserted in the pipe hole (D).

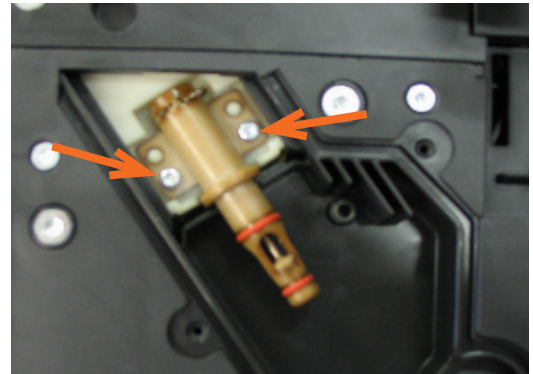

Tighten the screws of the heater valve asm..  
**WARNING:** ensure both screws are pushed fully down before tightening.

## 7.7 Pump

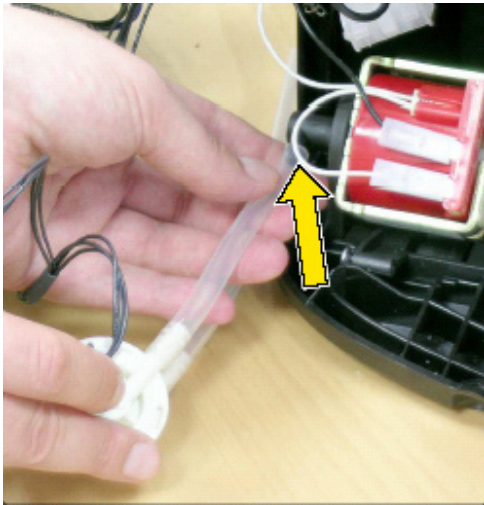

Withdraw the silicon tube that comes from the turbine.

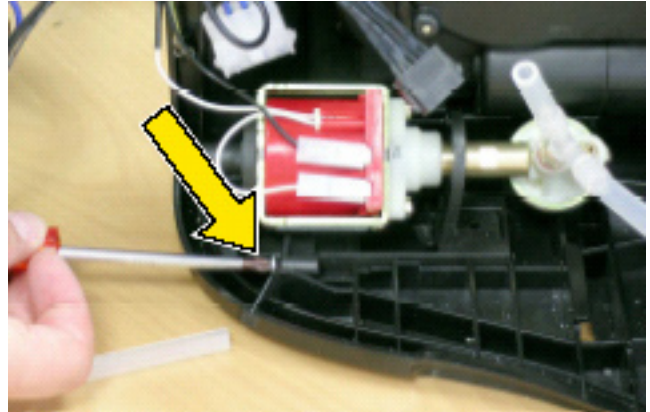

Loosen the screw securing the pump carriage.



Move the pump carriage forward and extract the unit (carriage, pump and membrane).

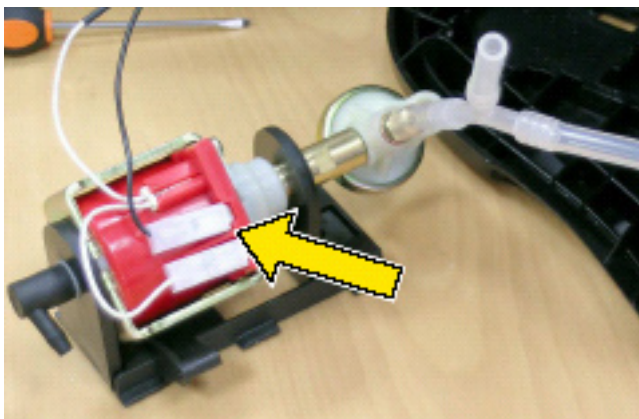

Detach the electrical connections and silicon tube of the pressure relief pipe.

**Assembly:**  
to assemble, follow the above sequence in reverse order.

## 7.8 Heater unit and multiway valve

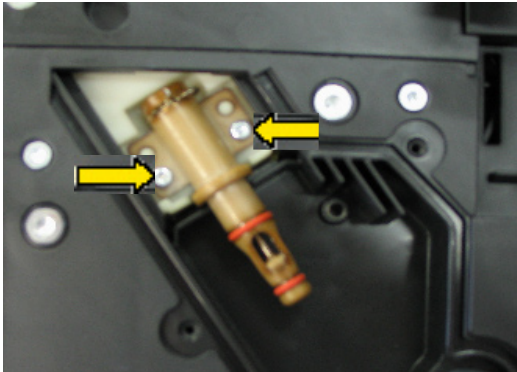

Loosen the heater valve screws.

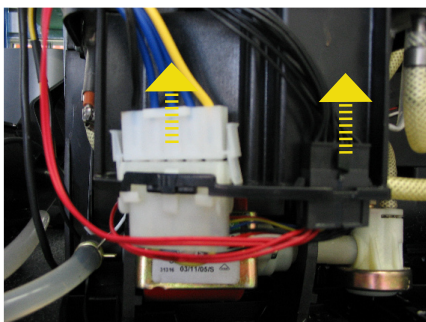

Detach the connectors as indicated.

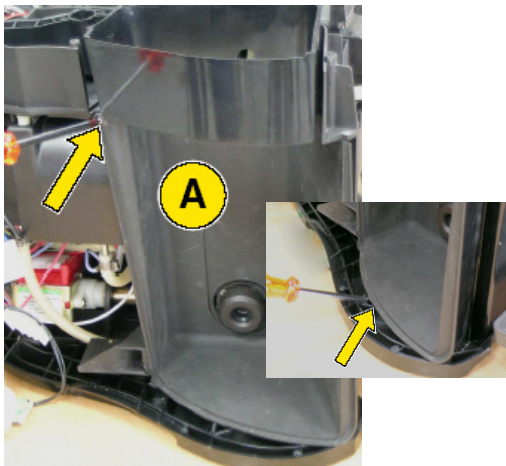

Loosen the screw securing the protection casing (A) of the water tank, detach the base of the casing from the retainer by lifting it using a screwdriver and pulling it outwards.

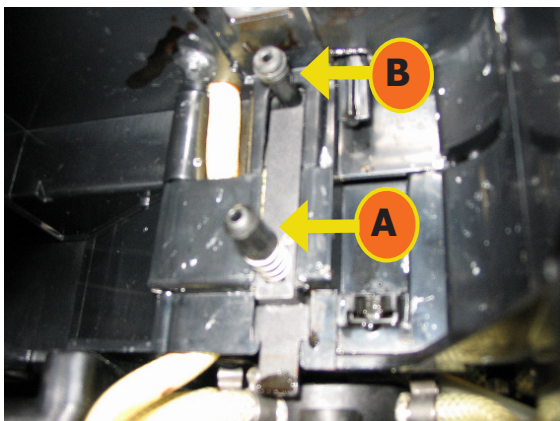

Detach the milk connector (A), extract and pull steam connector (B) downwards.



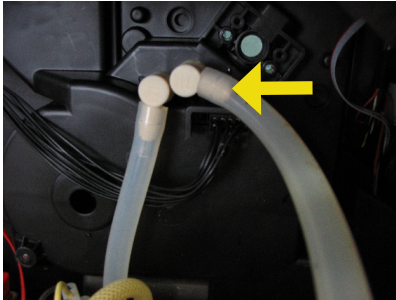

Remove the drain tube connector.

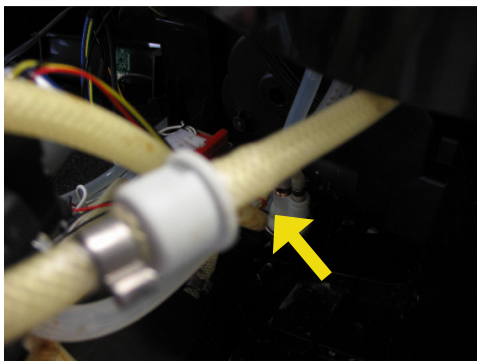

Withdraw the tube from the check valve.

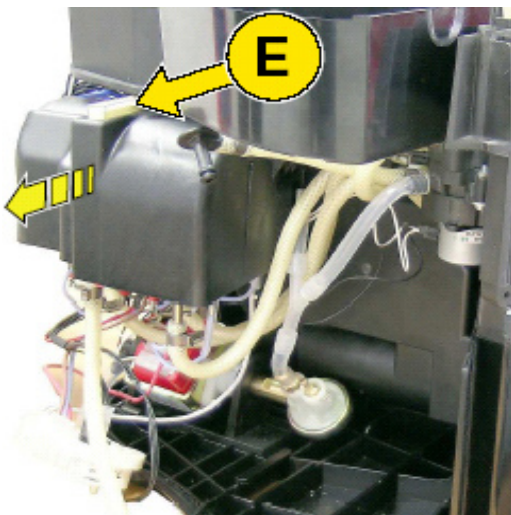

Withdraw the heater unit by sliding it along its guide (E).

Depending on the work required, access the heater unit or multi-way valve.

## 7.9 Heater

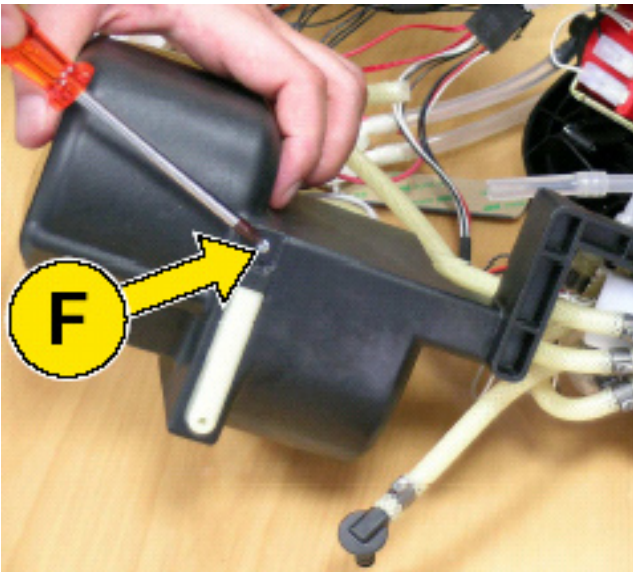

Remove the casing by removing screw (F) and withdraw the heater assembly from the casing.

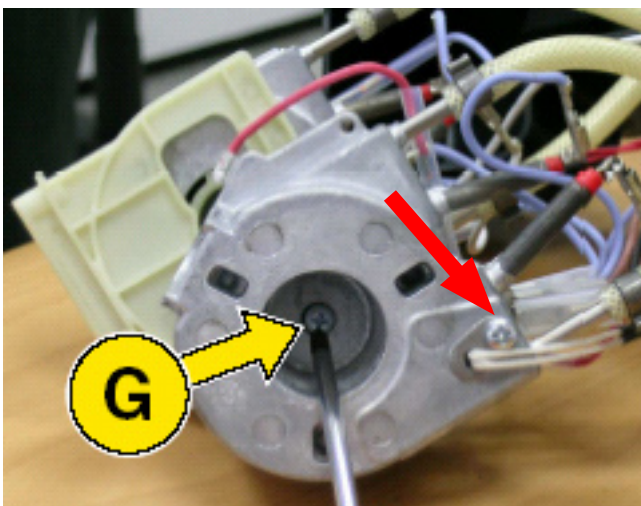

To separate the heaters from the plastic support, loosen the internal screw (G) to release the coffee heater and the screw highlighted in red to remove the temperature sensor.

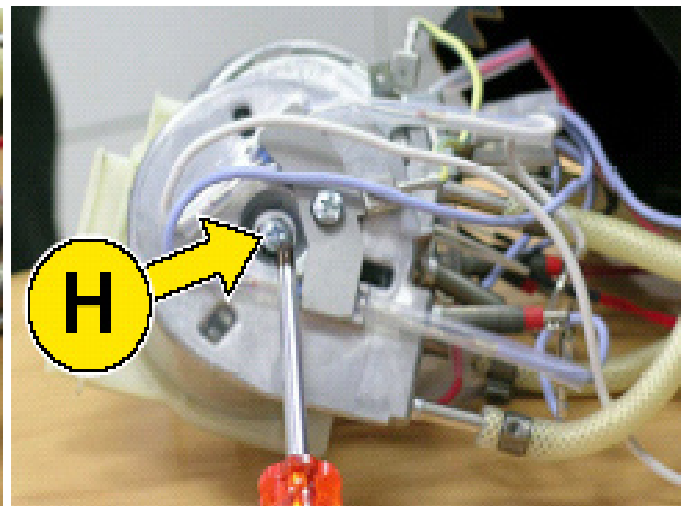

Loosen the external screw (H) to release the steam heater.

## 7.10 Multi-way valve

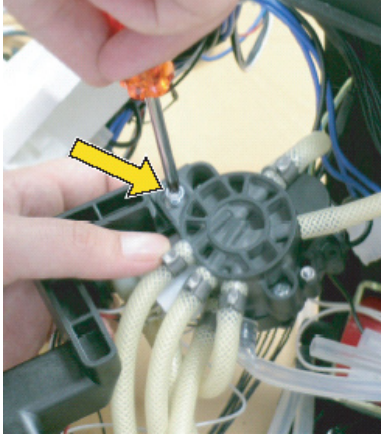

Remove the multi-way valve from the casing protecting the heaters, by loosening the screw as indicated.

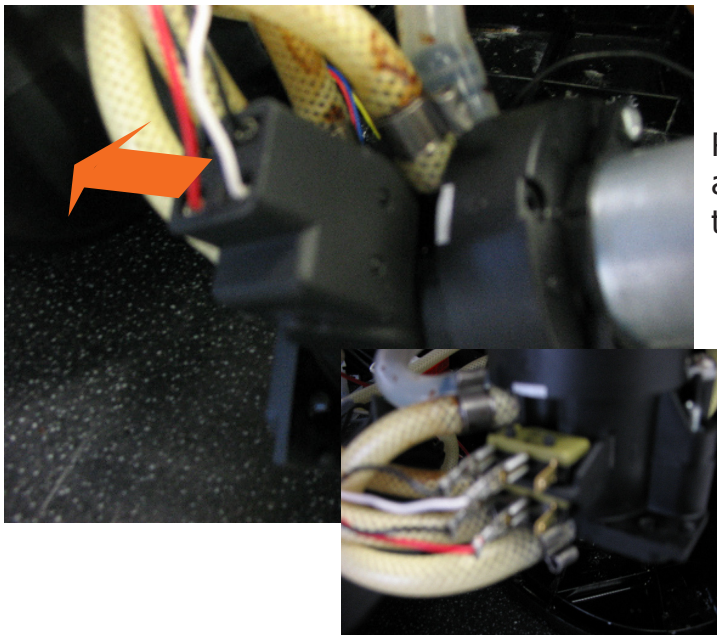

Remove the cover of the microswitches and disconnect the wires from the latter.

Disconnect all water hoses from the opposite side of the multi-way valve. The multi-way valve is supplied complete with hoses.

## Touch and Ring multi way valve assembly

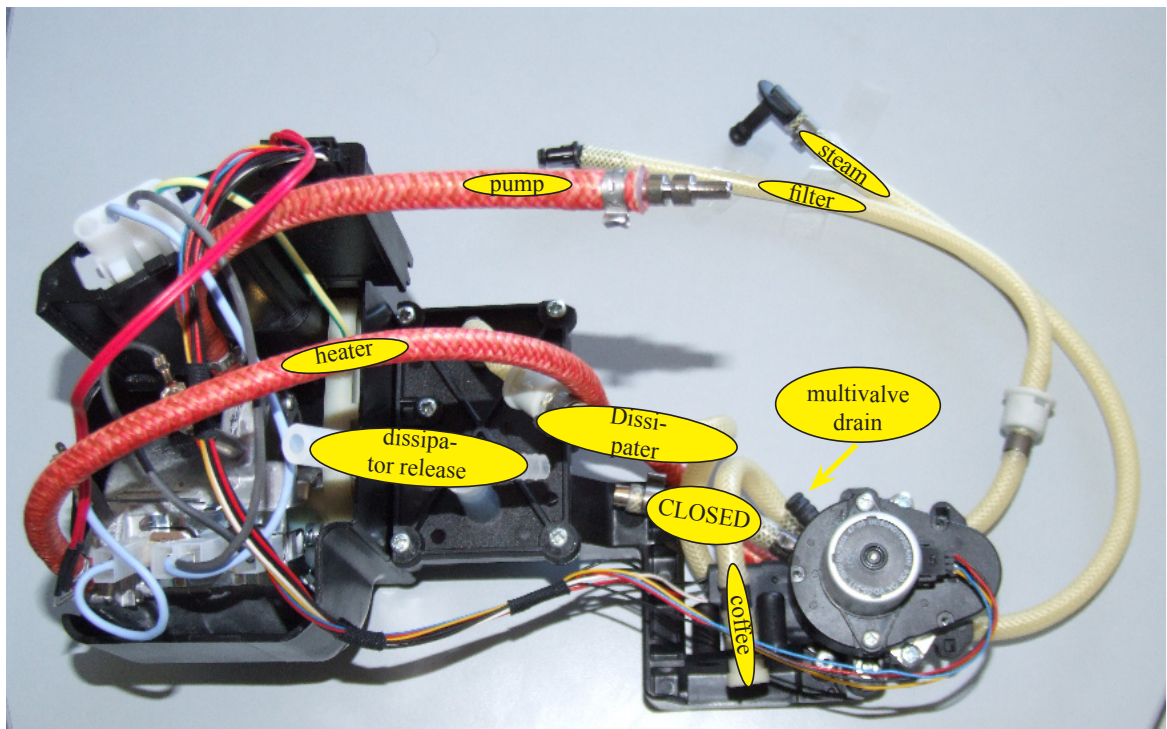

The pressure must be released on single heater models to reset the coffee or hot water functions.

The steam will be cooled in the dissipator and released into the drip tray below the brew group.

## 7. 11 OETIKER clamp assembly and disassembly

### Heater clamps

#### 1 HEATER

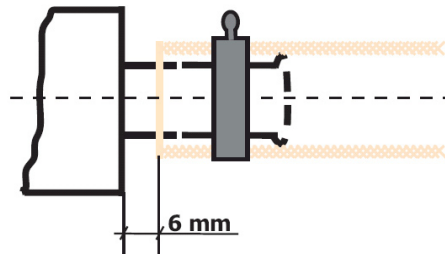

Illustration (1) shows the assembly position of the clamp on the heater connector.

### Multi-way valve clamps

#### 2 Multi-way valve

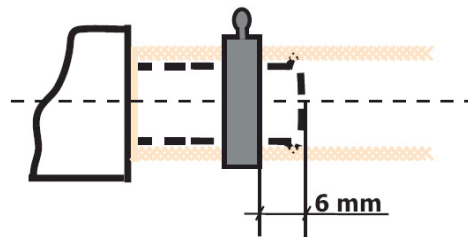

Illustration (2) shows the assembly position of the clamp on the plastic connector of the multi-way valve.



Use suitable pliers to tighten the clamp. Ensure correct tightening (A) and positioning as shown in illustrations (1) / (2).



To remove the clamp, use a pincer as shown in (B).

## 7.12 Coffee grinder

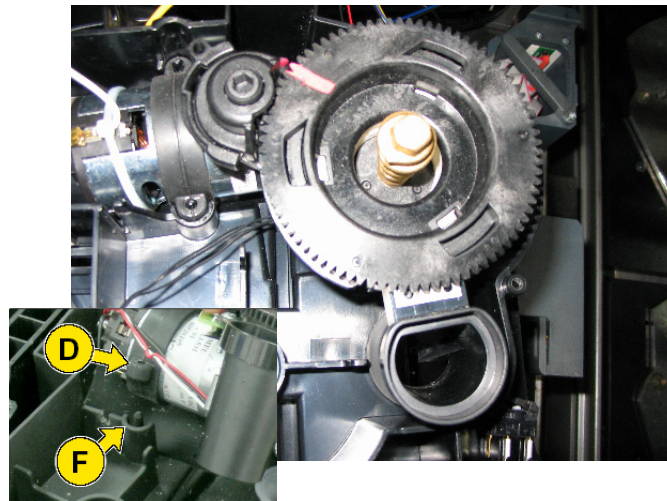

Detach the connectors from the board and withdraw the coffee grinder by pulling it upwards to release slot (D) from pin (F).

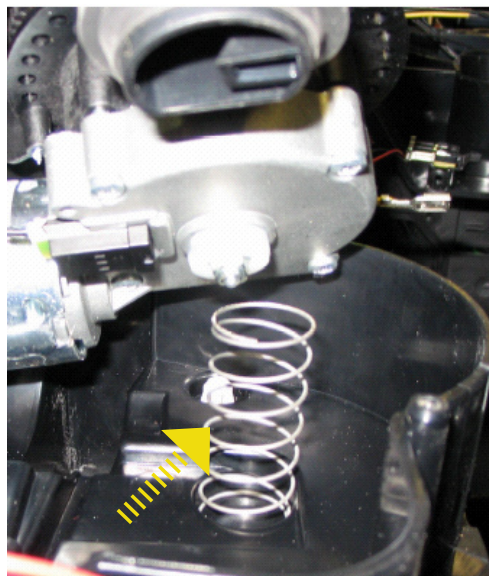

Ensure that the spring indicated is aligned correctly in its seat.

### 7.13 Grinder adjustment/assembly and disassembly

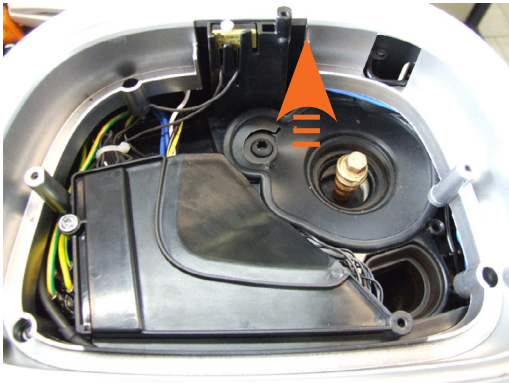

Remove the coffee container and rubber seal.

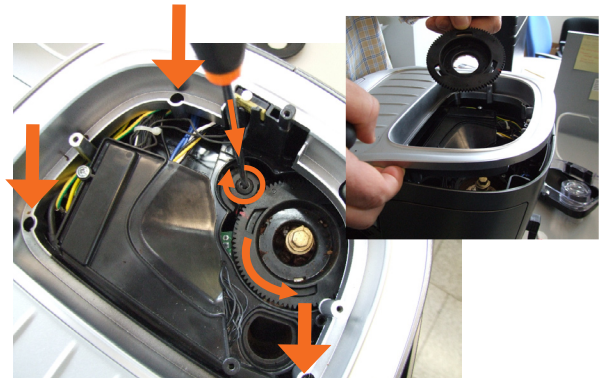

To remove the upper grinder support loosen the three screws as indicated, then use a hex key, turning it clockwise to release the grinder support, from the bayonet coupling.



To remove the upper burr, rotate anti-clockwise until it detaches from the bayonet coupling.

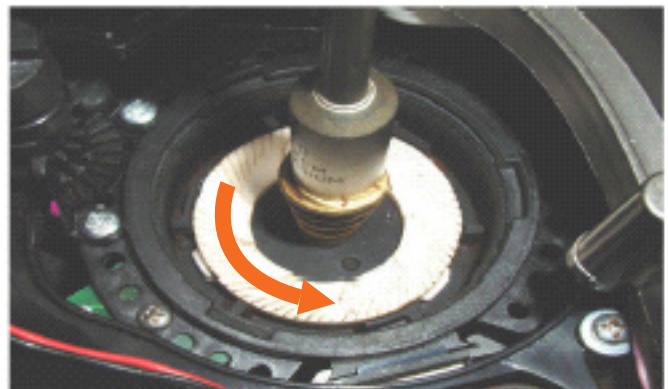

On the lower upper burr, keep the increment pin as indicated locked in position and proceed as shown in the figure above.

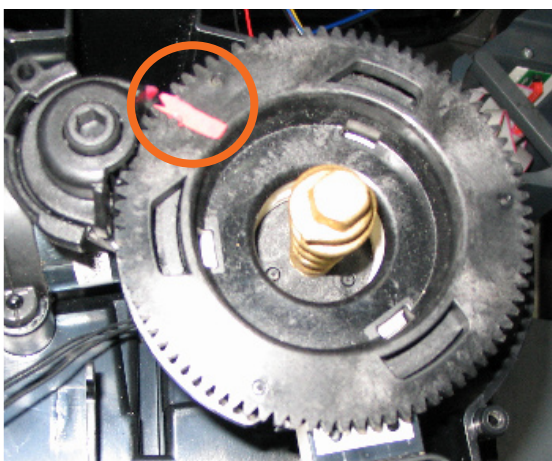

When refitting the upper grinder support, take care to reposition the mark as shown in the photo.

## 7.14 Grinding adjustment

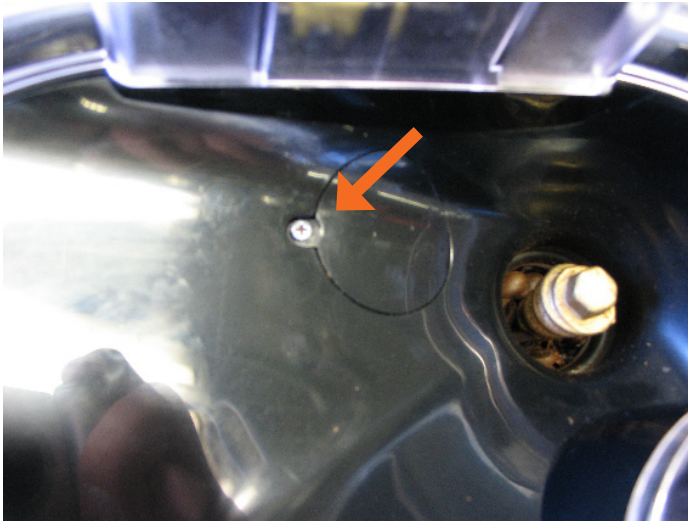

Remove the screw from the door.

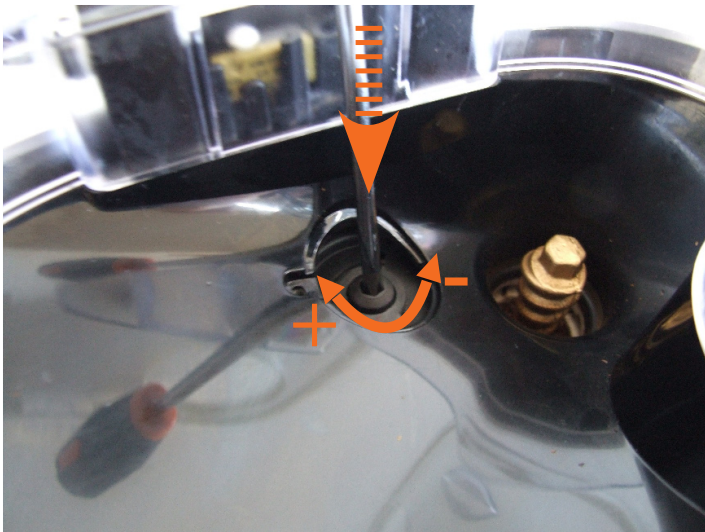

To adjust grinding press on the element with a hex key.  
 (+) = Coarsegrinding  
 (-) = Finegrinding.

### WARNING:

- Grinding must be adjusted with the motor stationary.
- Adjust the grinding level one step at a time.
- After completing settings, start the coffee cycle and run two grinding cycles.
- Repeat the operation in the event of further adjustments.



### 7.15 Auto cappuccino.

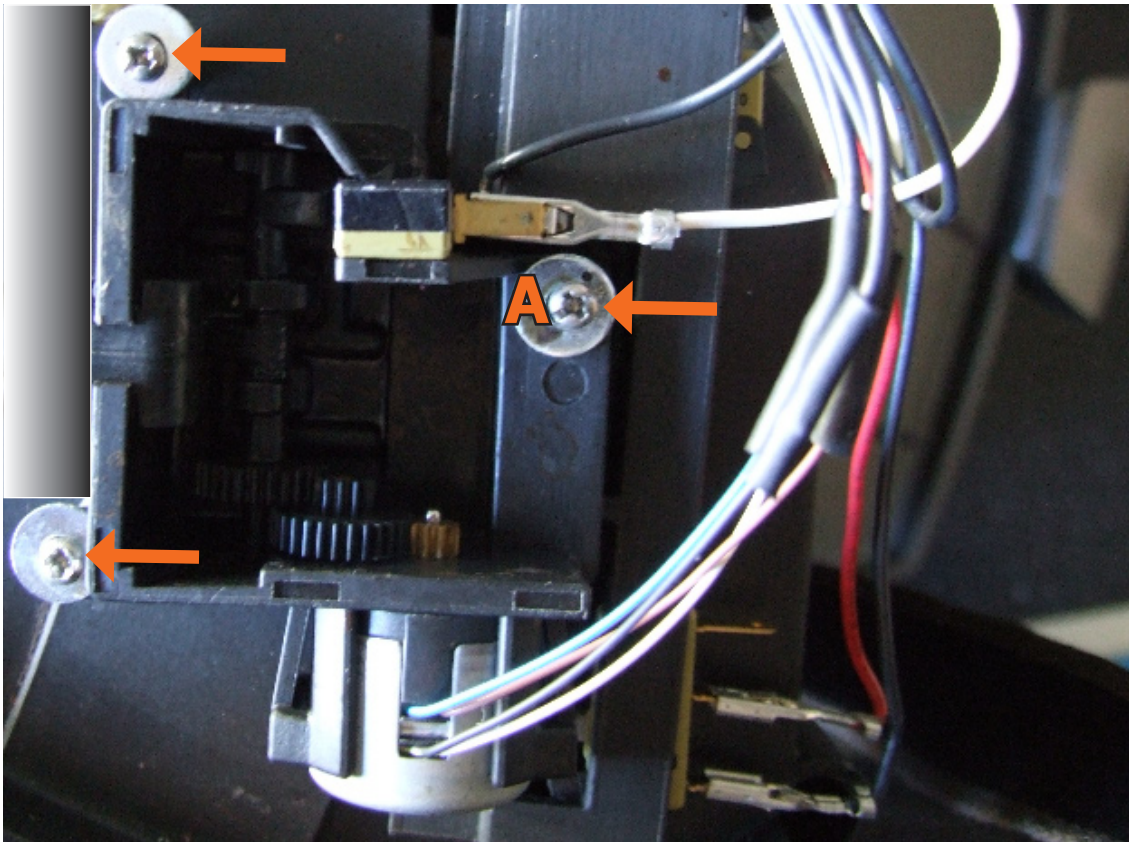

Withdraw the connector from the electronic board and loosen the three screws.

To ensure the micro activates safely, it may be necessary to insert a flat 3.2 x 9 washer (part code U201.001) beneath the front anchor screw "A".

### 7.16 Motorized drip tray.

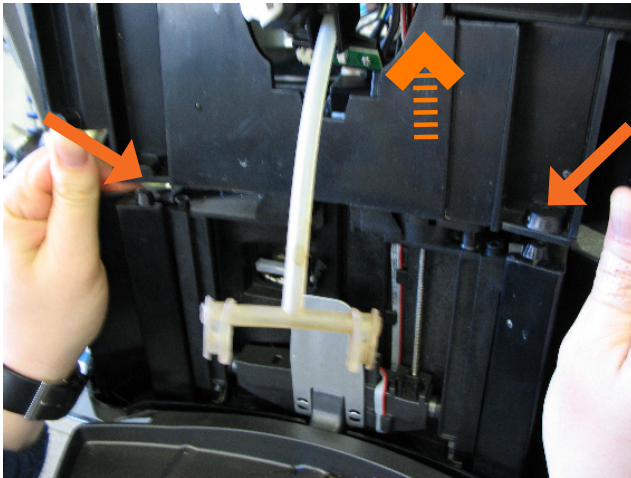

Move the tray to the lower position. Loosen the screws as indicated and lift the upper section. Remove the motorized tray from the seats by pulling upwards.

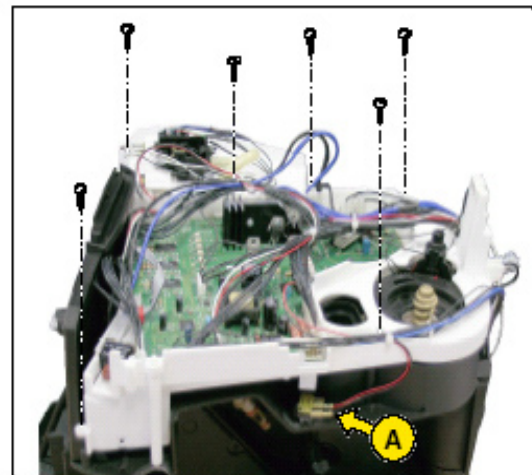

Loosen the screws securing the horizontal plate, remove the connectors from the board and lift the horizontal plate slightly to remove them.



For access to the sensors, loosen the two screws to remove the casing below the drip tray.

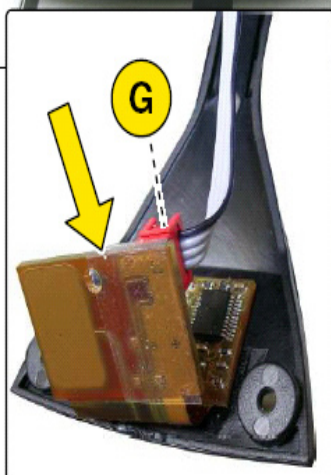

Remove electrical connections (G) as indicated.

**Disassembling motorized tank Stepper motor**

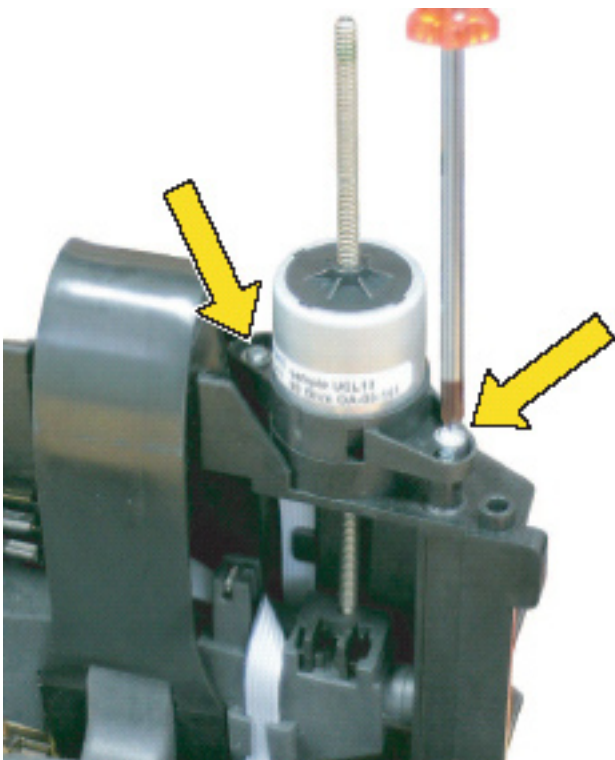

Loosen the two screws to release the electric motor with worm gear.

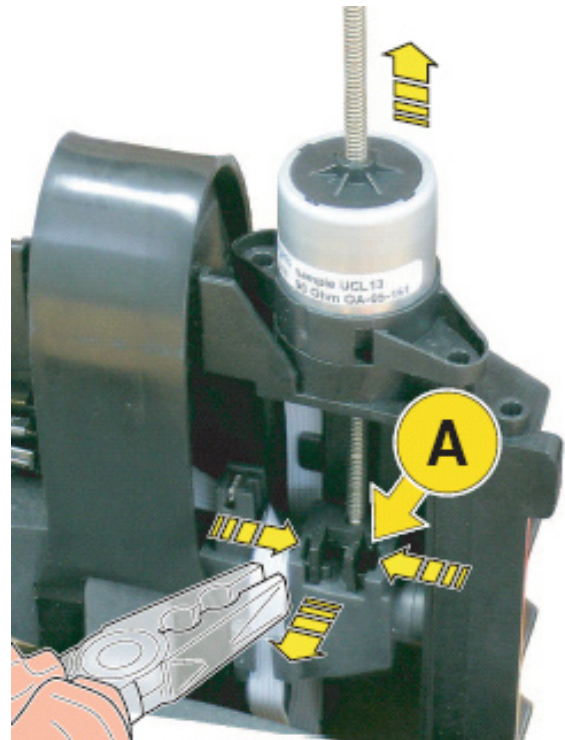

To withdraw the stop (A), use pliers to grip the tabs securing the lifting system to the base and pull outwards. Withdraw the electric motor with worm gear from above.

***SECTION 8***  
***SERVICE***  
***SCHEDULE***

**REV.01**

### 8.1 Routine maintenance check list

**S= Replacement**

**R= Service**

**P= Cleaning**

**D= Descaling**

**C= Inspection**

**\*= Number of beverages dispensed.**

Components	Task			Reason	Article
	Maintenance	5,000*	10,000*		
Casing, tanks, containers, power cable	C	C	C	Dirty, damaged	See documentation (Exp. drawng)
<b>Water, coffee and milk lines</b>					
GACO DIM 14 seals	S	S	S	Wear	
Water filter	S	S	S	Dirty, hygiene	
Silicon tube	C	D	D	Dirty, scale, leaks	See documentation (exp. drawng)
Turbine	C	D	D	Dirty, scale, leaks	See documentation (exp. drawng)
Heater	C	D	D	Dirty, scale, leaks	See documentation (exp. drawng)
Multi-valve	C	D	D	Dirty, scale, leaks	See documentation (exp. drawng)
Heater pin o-ring	S	S	S	Dirty, scale, leaks	
Brew group	P	P	P	Dirty, hygiene	See documentation (exp. drawng)
Cappuccinatore	P	P	P	Dirty, hygiene	See documentation (exp. drawng)
<b>Coffee grinder</b>					
Grinders	P	P	P	Dirty, hygiene	See documentation (exp. drawng)
Check strength of ground coffee	C	C	C	Grain size and dose	
<b>Unit</b>					
Cleaning	C	R	R	Dirty, hygiene	
Lubrication	C	R	R	Dirty, hygiene	
O-ring	C	S	S	Wear	See documentation (exp. drawng)
Full service	C	C	C	Wear	
<b>Othertasks</b>					
Descale	C	D	D	Then check condition of components	
Temperature check	C	C	C	Client information	
Explanation of fault	C	C	C	Client information	
<b>Safety check</b>	<b>C</b>	<b>C</b>	<b>C</b>	<b>Always</b>	
Packing	C	C	S	Check, always	Use new packaging if necessary