



Philips Consumer Lifestyle

Service Manual

PRODUCT INFORMATION

Safety

- This product meets the requirements regarding interference suppression on radio and TV.
- After the product has been repaired, it should function properly and has to meet the safety requirements as officially laid down at this moment.

TECHNICAL INFORMATION

- Colour : Star white and resilient blue

Design features

- Dust chamber and watertank : Translucent

Performance

- Power consumption : 1500 W
- Noise level (Lc IEC) : <75 dB
- Input power (max) : 1500 W

Steam Management

- Heating-up time : <30 s
- Runtime (steaming) : 20 min
- Steam capacity : 20 g/min
- Steam temp. at nozzle : >100 °C
- Watertank size : 450 ml

Usability

- Adjustable telescopic stick : 100 - 120 cm
- Cord length : 6 m
- Removable stick assembly : From body (with a screw)
- Stand by mode : Auto steam shut-off

Weight and dimensions

- Dimensions microfiber pad : 27 x 11 cm
- Dimensions nozzle : 28 x 18 x 4.5 cm
- Dimensions appliance : 16 x 32 x 112 cm
- Weight (kg) : <3 kg

ACCESSORIES

- 1 parking pad
- Cleaning : 2 microfiber pads, Fast rotating brush

OPTIONAL (accessories)

- FC8056 : 2 microfiber pads and 1 filter assy

- To replace the Rotating Brush (14) of the nozzle:
Turn the appliance upside down, open the Roller Brush cover (18) by lifting it. Take the brush out by lifting it on the right side and moving it out sideways to the right.

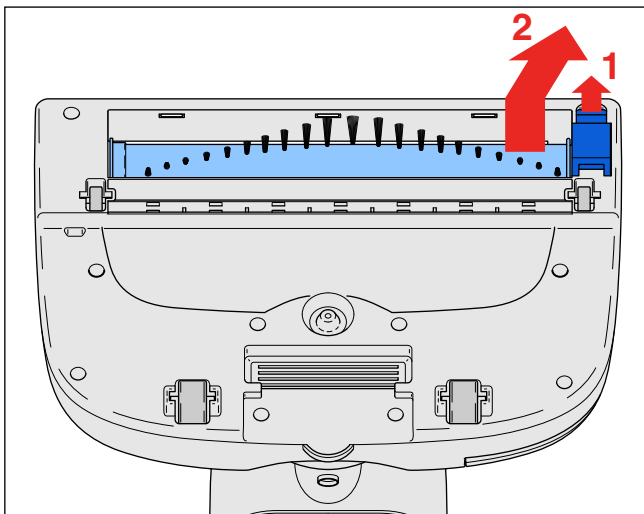

- To place the Brush, position the Brush over the Roller Holder Assy (13) then “click” the Brush into place at the Roller Brush cover and close the Roller Brush cover.

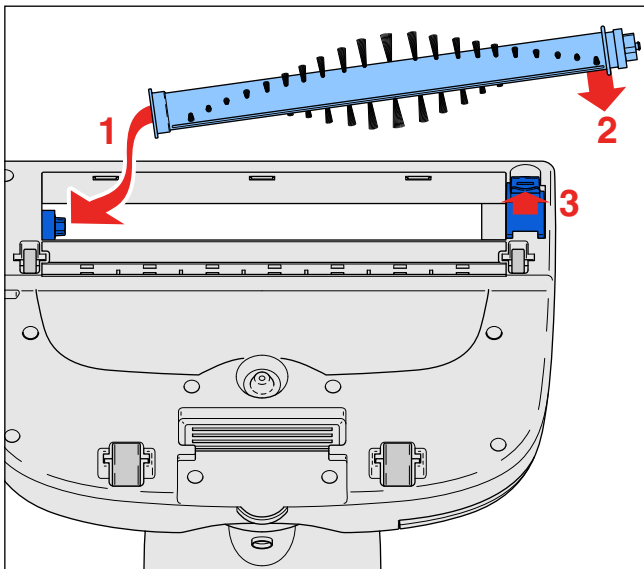

- To replace the Brush Motor (15), Driving belt (12) and Roller Holder Assy (13):
Remove the 10 screws (D) on the bottom of the Nozzle and push the 3 clickknocks on the front side with a screwdriver, now the components can be reached.

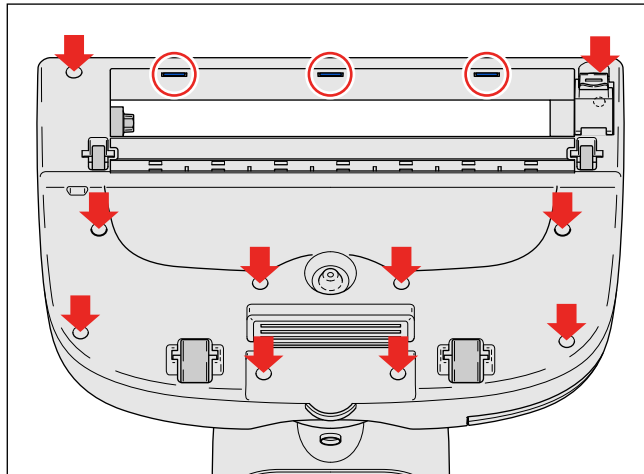

- To replace the pump (10):
First remove the Water Tank (3) and Filter Assy (4). Remove the 4 screws (C), and remove the cover. Now the pump is visible. Remove the clips from the hoses and the valve and replace the pump.

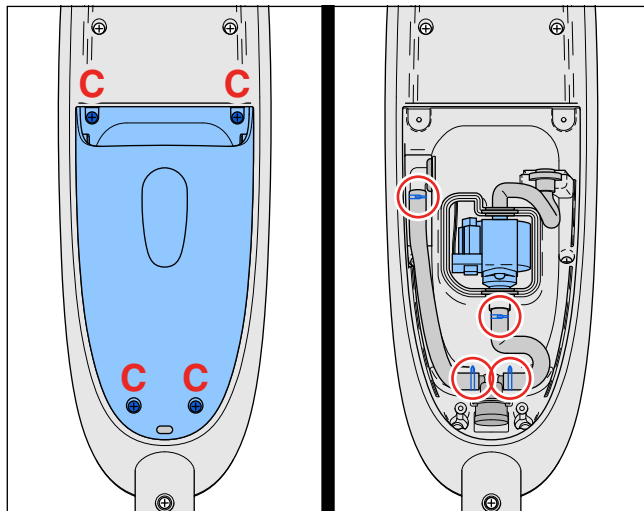

Remark:

- You can use the delivered Pin (5) in the small plastic bag for “unclogging” the little hole on the bottomsides of the Nozzle in case some calcium is present in the hole.

Pos	Service code	Description	Remark
1	9965 100 60773	Handle	
2	9965 100 60772	Adjustable telescopic tube	
3	9965 100 60777	Water tank	
4	4322 004 93841	D.Calc filter	
5	9965 100 60767	Pin for decalcification	
6	9965 100 60768	Cleaning padholder	
7	4322 004 93831	Cleaning pad	
8	4322 006 09351	Cordset Octopus EU	FC7020/01
8	4322 006 09391	Cordset Octopus AU	FC7020/71
8	4322 006 09361	Cordset Octopus China	FC7020/81
9	9965 100 60775	Front body (incl. Switch)	
10	4322 006 95031	Pump M2	220 - 240V ~ 50 / 60 Hz 18W
11	9965 100 60766	Dust tank	
12	9965 100 60771	Driving belt	
13	9965 100 60776	Roller Holder assy	
14	9965 100 60765	Rotating brush	
15	4322 006 95021	Motor H41-5HA1033B	230V 50 Hz
16	9965 100 60778	Wheel big	
17	9965 100 60774	Wheels small	
18	9965 100 60769	Roller Brush cover	

CIRCUIT DIAGRAM

