



Philips Consumer Lifestyle

# Service Manual

## PRODUCT INFORMATION

### Design

- Color : Deep black

### Usability

- Tube type : Metal 2-piece telescopic tube
- Handgrip : Ergonomic grip with air slider
- Tube coupling : SmartLock
- Action radius : 9.0 m
- Cord length : 6.0 m
- Carrying handle : Top and front
- Dust bag full indicator
- Park or storage assist : Vertical and horizontal
- Power control : Electronic on appliance
- Wheel type : Rubber

### Filtration

- Dust bag type : S-bag Ultra Long Performance
- Dust capacity : 5 l
- Exhaust filter : Micro filter
- Motor filter : Triple layer

### Safety

- This product meets the requirements regarding interference suppression on radio and TV.
- After the product has been repaired, it should function properly and has to meet the safety requirements as officially laid down at this moment.

## TECHNICAL INFORMATION

### Performance

- Noise level (Lc IEC) : 79 dB
- Airflow (max) : 47 l/s
- Input power (IEC) : 1800 W
- Input power (max) : 2000 W
- Suction power (max) : 450 W
- Vacuum (max) : 34 kPa

### Weight and dimensions

- Dimensions of product : 500 x 310 x 300 mm (L x W x H)
- Weight of product : 5.4 kg

## ACCESSORIES

- Standard nozzle : Tri-Active nozzle
- Additional nozzle : Hard floor nozzle
- Accessories : Crevice tool, Small nozzle
- Accessory storage : On tubeclip

## OPTIONAL (accessories)

- Starter kit FC8060 (Filters and dustbags)

- To open the appliance, first remove outlet grill (28) and exhaust filter (7).
- Remove Dustcover (1) using a screwdriver (see picture).

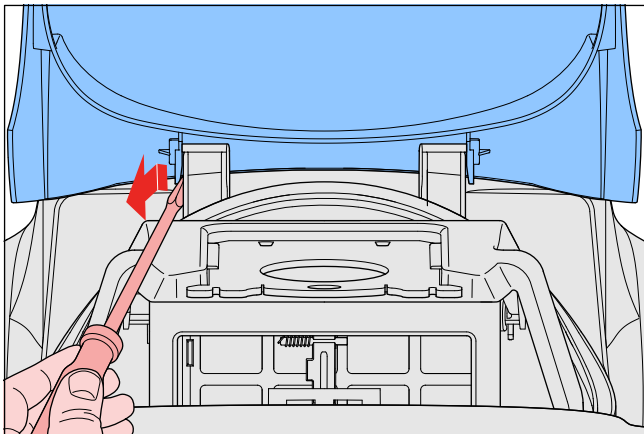

- To reach the inner parts for repair you must first remove the Top housing with its attached parts.
- Remove On/Off button (5) and cordwinder button (6), this can be done with a screwdriver (see picture).

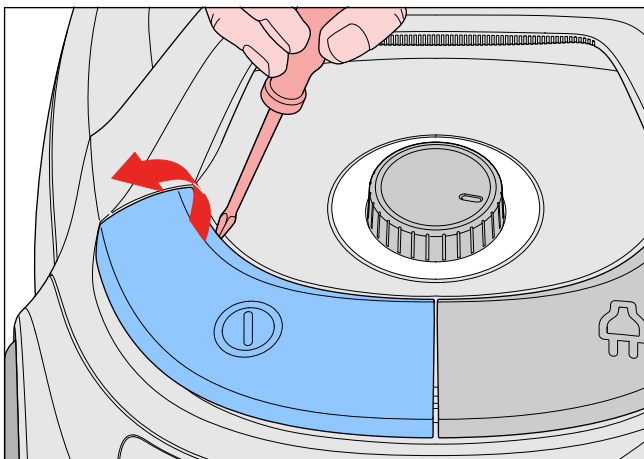

- To remove Handle cover (8) first release the 2 snap connections on the backside (see picture).

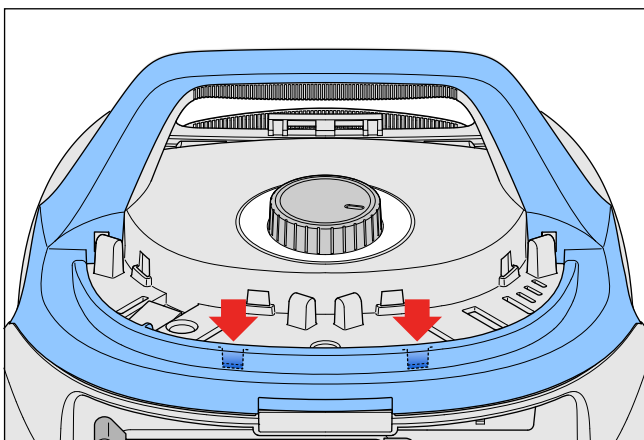

- Then with a small screwdriver lift the Handle cover over the nock on the Top housing (see picture).

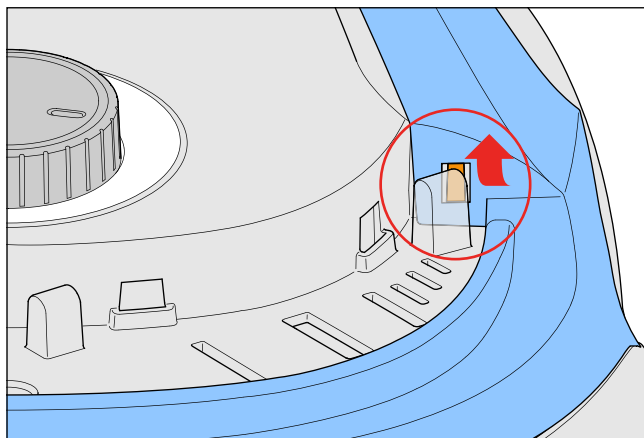

- Now you can with a screwdriver remove the complete Handle cover from the housing (see picture).

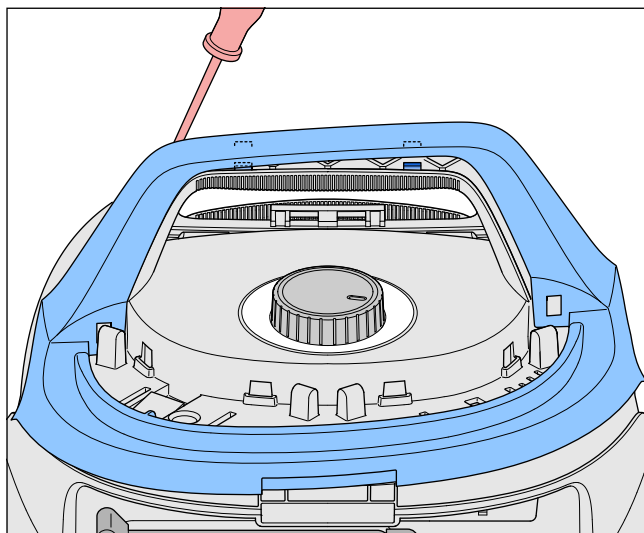

- Remove the 2 screws A which hold Handle (9) and screw B (see picture).

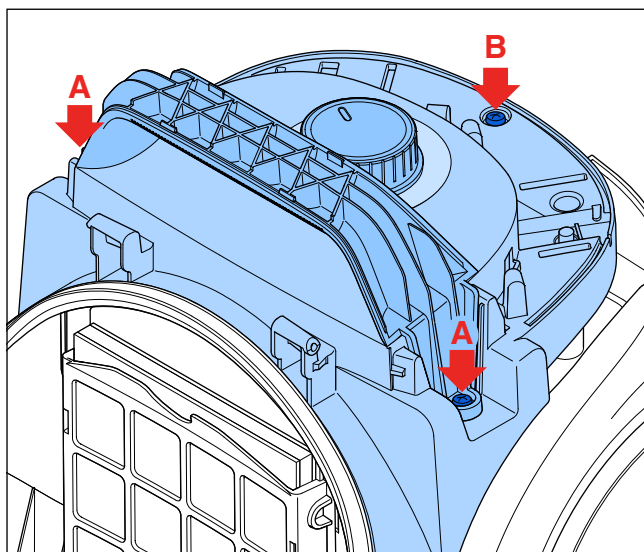

**Remark:**

When assembling the Top housing check that Turn knob (11) is in the correct position relative to the position of the potmeter on the PCBA.

## DISASSEMBLY- AND RE-ASSEMBLY ADVISE

# FC9185/01

- When the Motor and/or Cordwinder have to be replaced the Upper housing (17) must be removed.
- First remove Brake lever (13) and the spring than remove screw C so you can remove cordwinder cover (14). Take care that the spring does not fall into the appliance! (see picture).

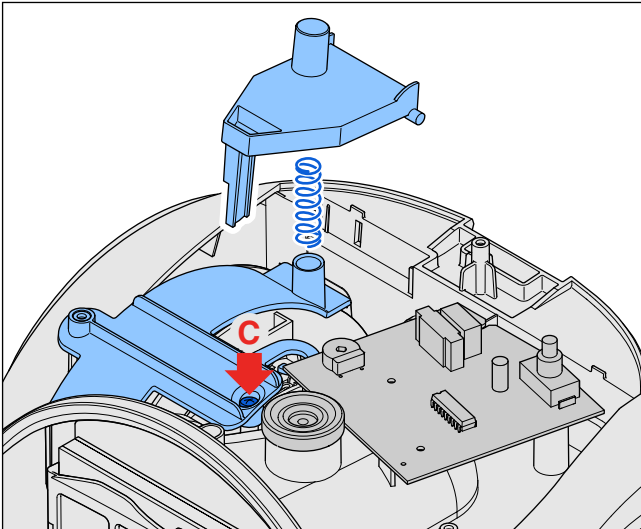

- After removing the 5 screws D and 3 screws E on the back side, the Upper housing can be separated from the Lower housing (see pictures).

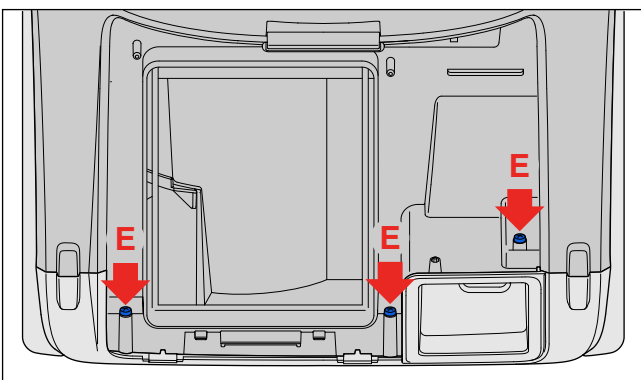
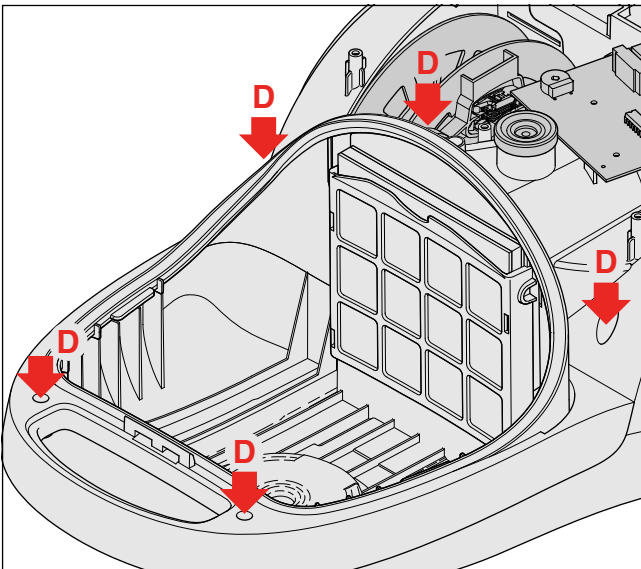

- When replacing the Cordwinder (21) the Lower housing insert (19) needs to be removed. Move the Lower housing insert upwards so the cordwinder can easily be removed (see picture).

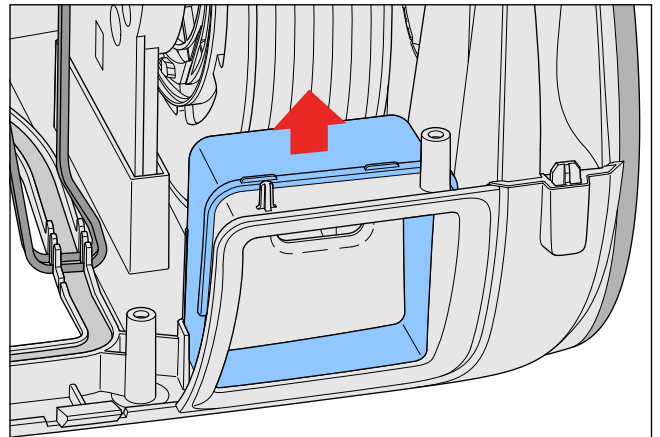

- When assembling take care that the wires from motor to cordwinder are correctly fixed (see picture).

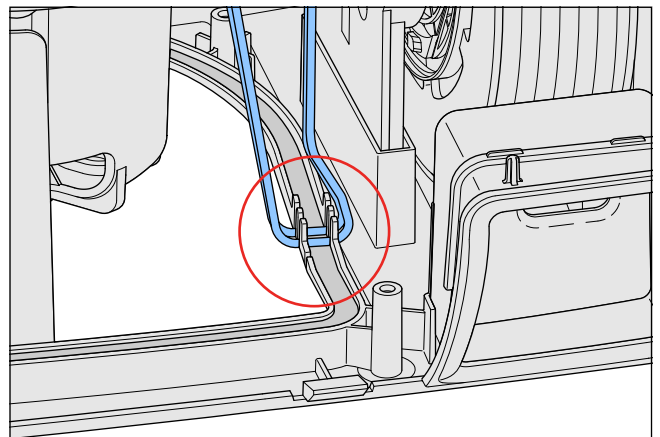

- The frame that holds Triple filter (18) is attached to the Upper housing, to remove the frame remove screw F (see picture).

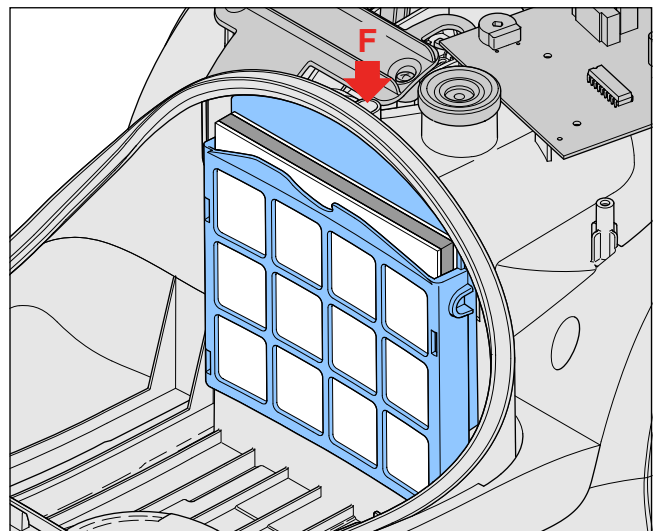

## DISASSEMBLY- AND RE-ASSEMBLY ADVISE

- To replace Caster assy (4) turn the appliance upside down, push the Caster assy with a screwdriver up and pull it out (see picture).

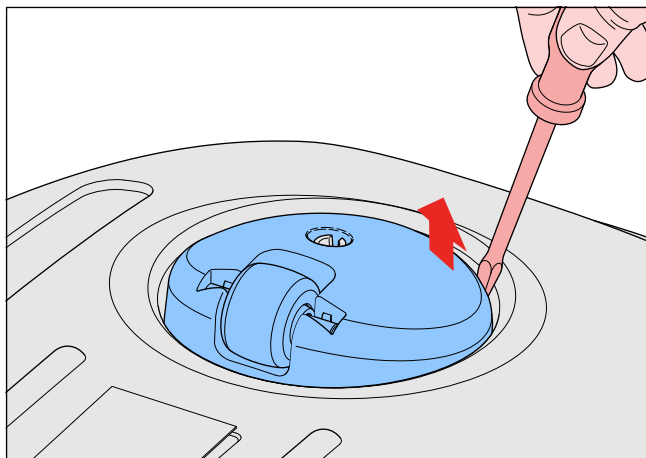

## WIRING DIAGRAM

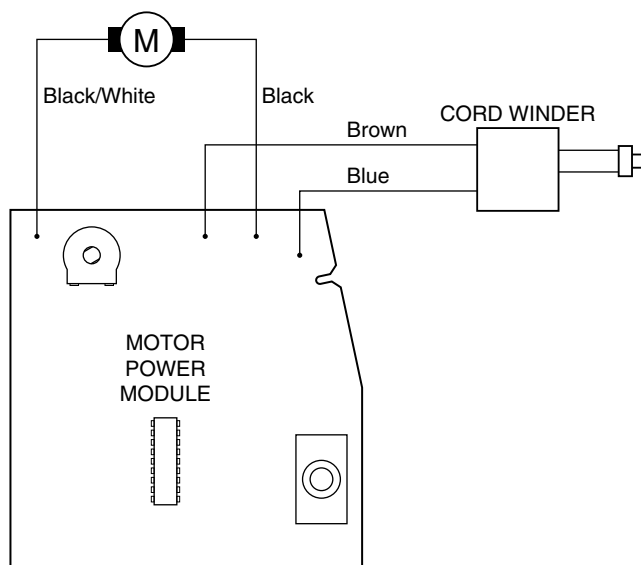

## CIRCUIT DIAGRAM

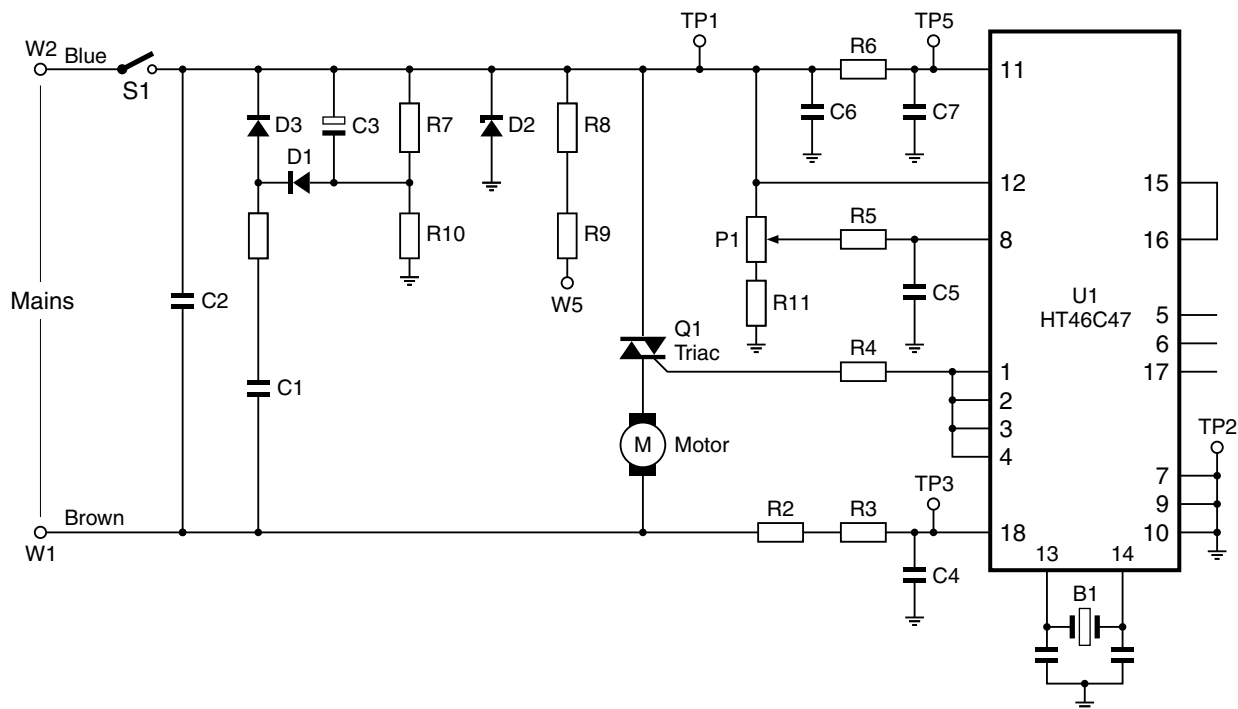

Pos	Service code	Description	Remark
1	4322 009 00651	Dust cover	Deep black unprinted
3	4322 003 46801	Dustbag holder	Deep black 8023 I
4	4322 005 33431	Caster assy	
5	4322 003 46671	On/Off pedal	Deep black 8023 I
6	4322 003 46681	Cordwinder pedal	Deep black 8023 I
7	4322 004 92913	Electrostatic filter	Phoenix
8	4322 003 46901	Handle cover	Deep black 8023 I
9	4322 003 46641	Top handle	
10	4322 003 46931	Top cover	Deep black 8023 I
11	4322 003 46651	Power control knob	Deep black 8023 I
12	4322 005 33661	Power control ring	Printed Silver Metallic
13	4322 003 46881	Brake lever	
14	4322 003 46691	Cordwinder cover	
15	4322 009 00701	Safety valve assy	
16	4322 006 24721	PCBA	Gulo HV
17	4322 003 46631	Upper housing	Deep black 8023 I
18	4322 000 39731	Triple Filter	
19	4322 003 46621	Lower housing insert	Deep black
20	4322 003 46611	Lower housing	Deep black
21	4322 005 33391	Cordwinder	6 m / 4.8 mm plug
22	4322 009 00691	Motor assy Service	
23	4322 000 39671	Silencer bottom	
24	4322 003 46871	Rearwheel lock	
25	4322 000 39711	Silencer top	
26	4322 000 39681	Silencer wall	
27	4322 003 46831	Rearwheel assy	Closed
28	4322 003 46661	Exhaust grill	
29	4322 003 46761	Exhaust grill lock	
30	4322 001 75293	Exhaust sealing	
31	4322 004 24631	Curved bend assy	Deep black
32	4322 004 24621	2 T.T. Tube	85 cm Cobra SmartLock
33	4322 004 24811	Accessory holder assy 2	
34	4322 004 24741	Tri-Active nozzle	Deep black SmartLock
35	4322 009 00741	Hose assy LE	Diam. 45 mm
36	4322 004 24801	HF Nozzle NE M300	Deep black Conical 35
37	4322 006 09921	Switch Nova KAN-J4 (B) 133	
40	4322 003 60381	Flexible shaft	

EXPLODED VIEW

FC9185/01

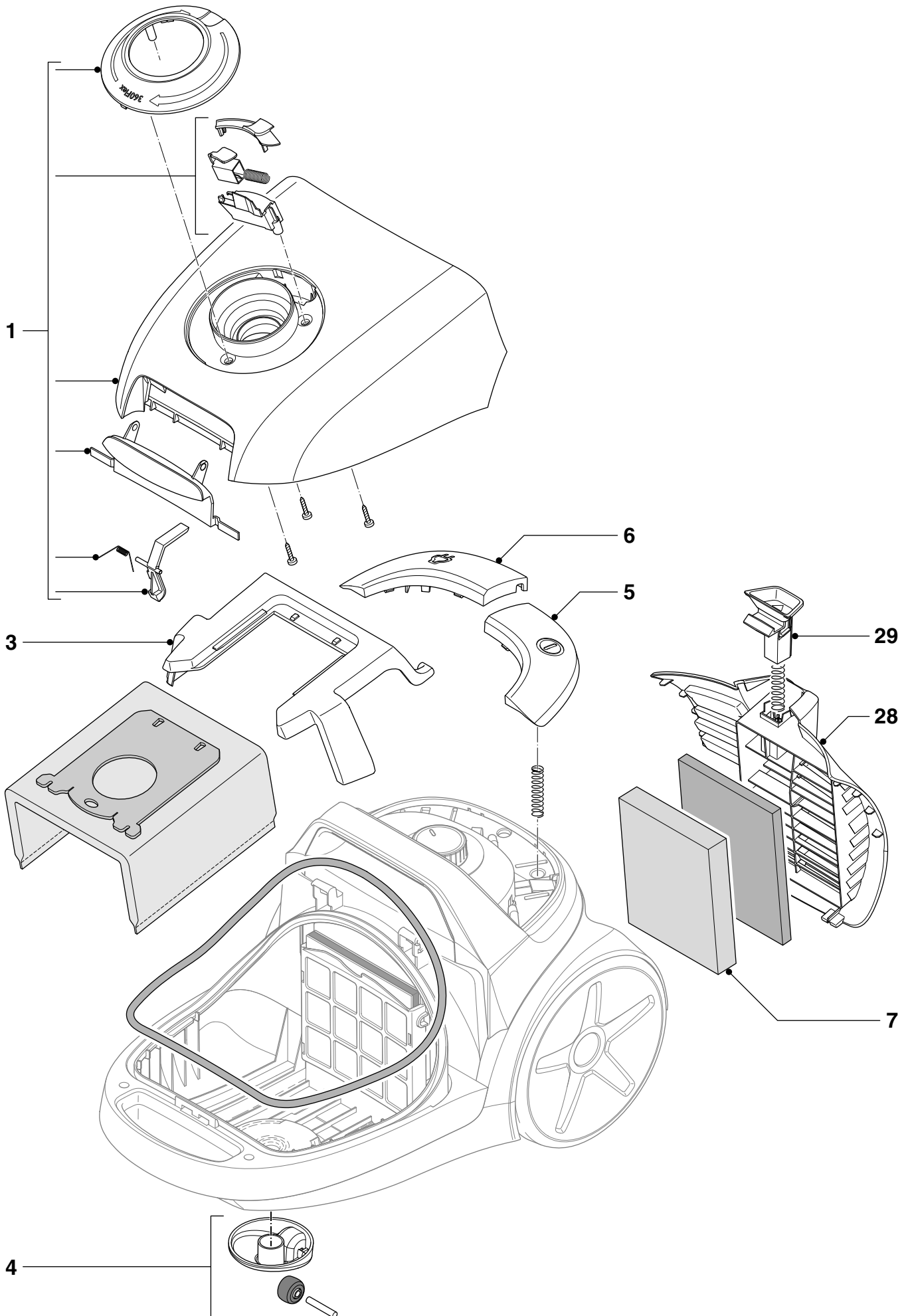

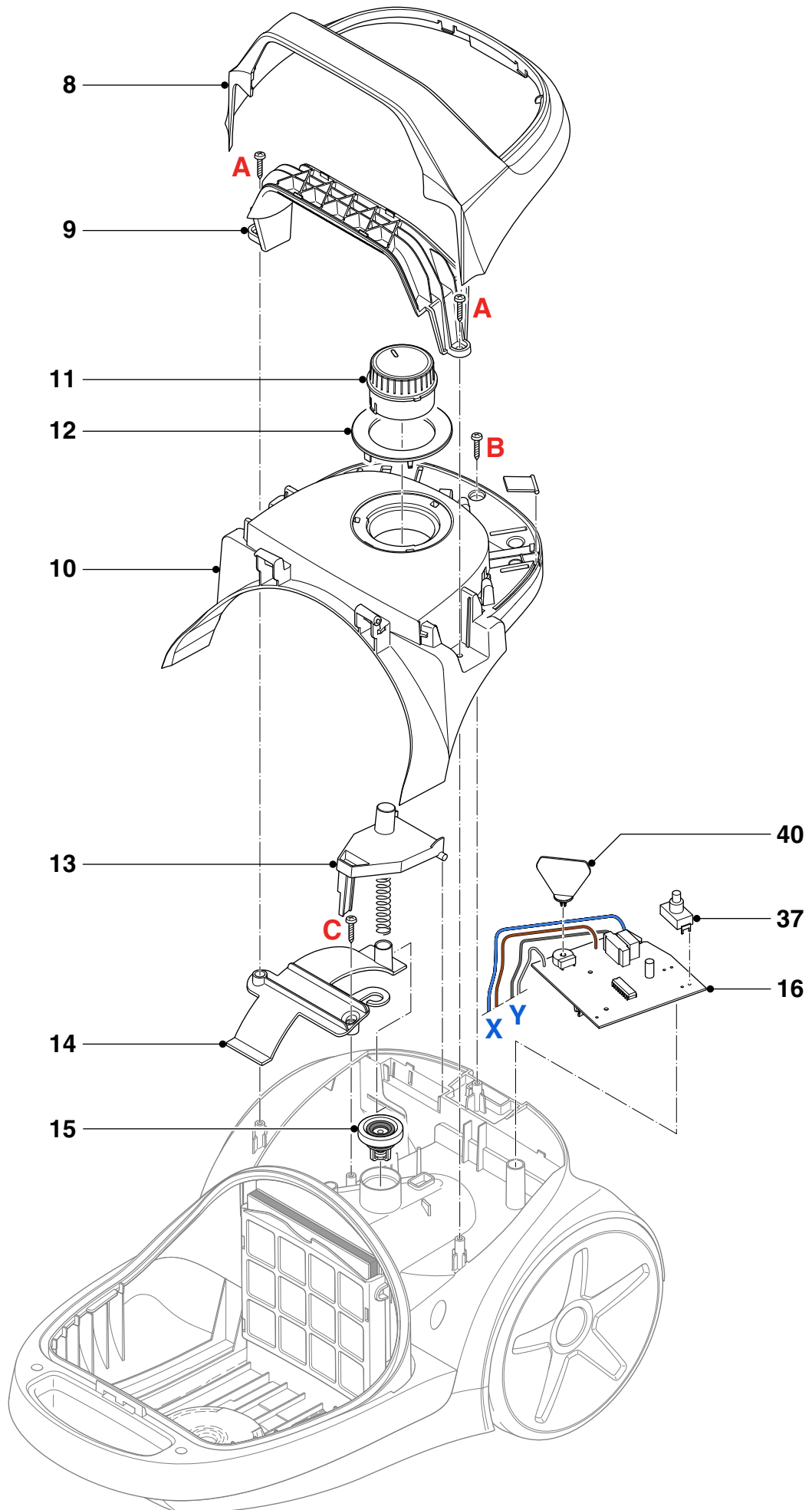



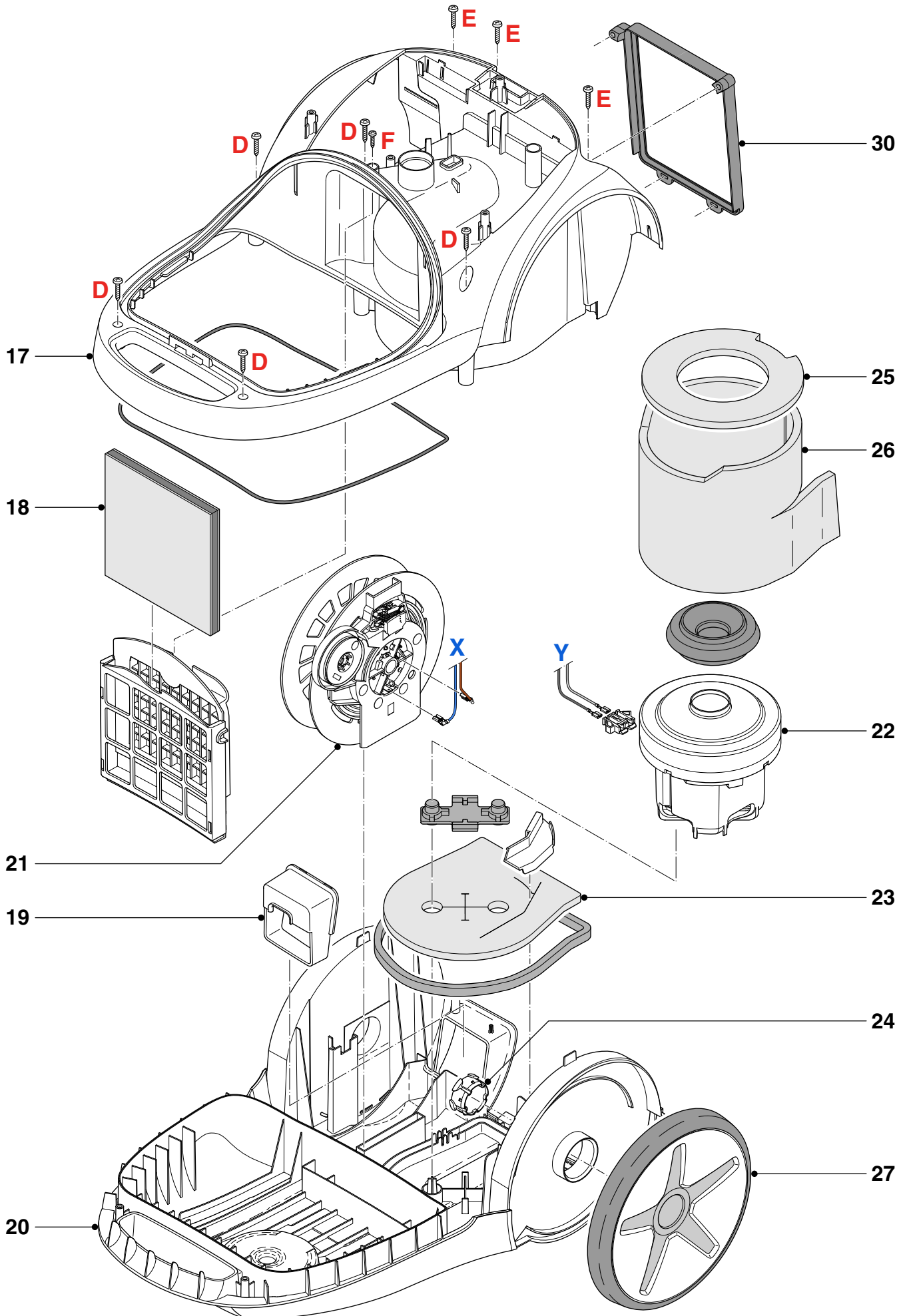



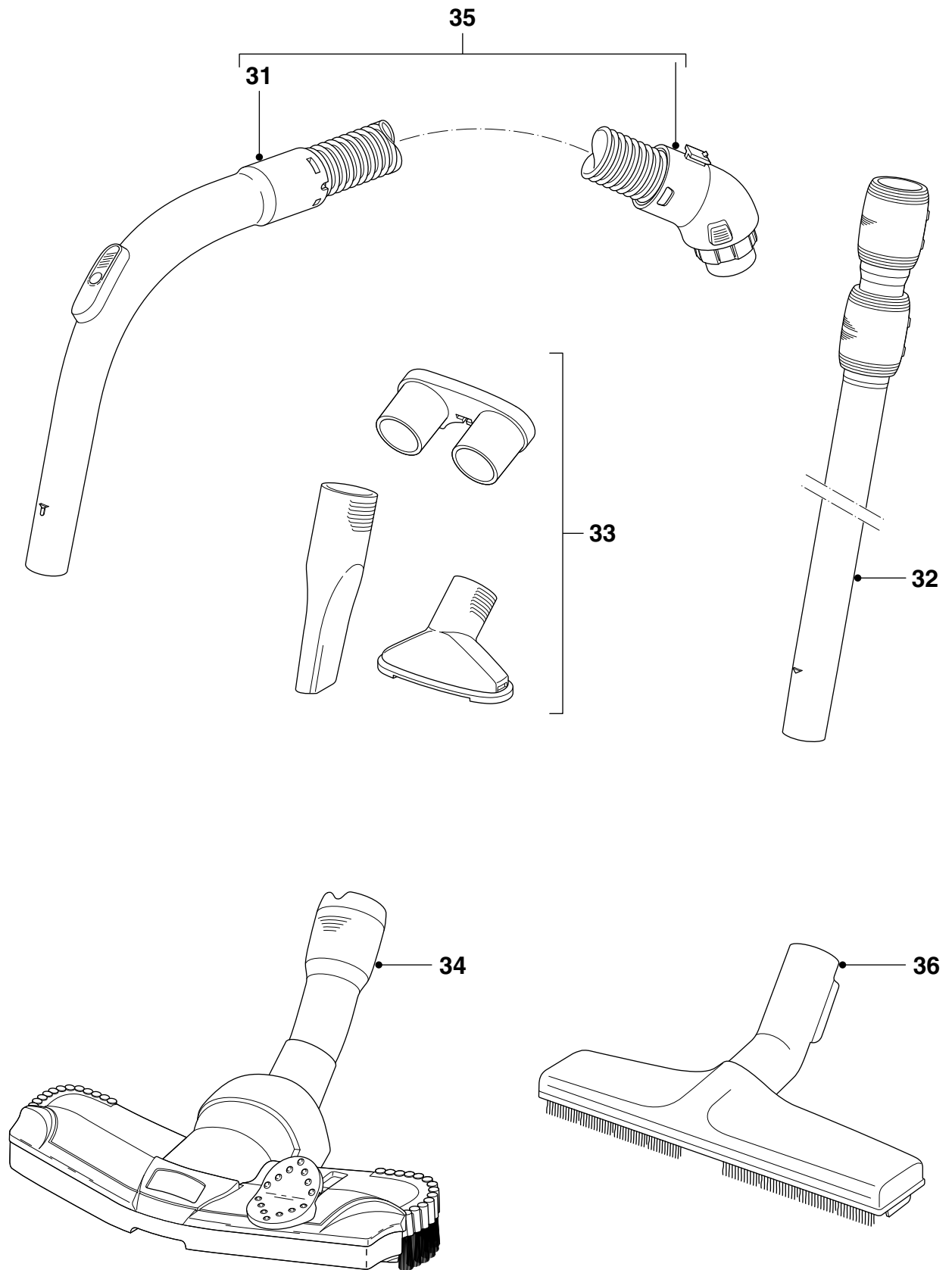

## Version history

13/07 Version 1.1 : FC91850/01 initial release.

14/11 Version 1.2 : In Parts List and Exploded view: Added Pos. 37: 4322 006 09921 Switch Nova KAN-J4 (B) 133.

16/06 Version 1.3 : In Parts List changed Pos. 30: 4322 001 75291 Exhaust seal into  
4322 001 75293 Exhaust sealing.

In Parts List and Exploded view: Added Pos. 40: 4322 003 60381 Flexible shaft.