

Service
Service
Service



Philips Consumer Lifestyle

Service Manual

PRODUCT INFORMATION

Fast & powerful crease removal

- Soleplate: SteamGlide
- OptimalTemp
- Continuous steam output
- Continuous steam output: 120 g/min
- Steam boost: 220 g
- Vertical steam
- Steam pressure: Up to 5 bar
- Steam tip
- Power: 2400 W

Easy to use

- Water tank capacity: 2200 ml
- Filling and emptying water: Extra large filling hole
- Refill any time
- Heat-up time: 2 min
- Safety auto off
- Storage solution: Carry lock
- Hose storage: Hose storage compartment
- Power cord length: 1.8 m
- Hose length: 1.6 m
- Safe for all fabrics: Even for delicates like silks
- Low water alarm

Calc management

- Suitable for tap water
- Calc clean solution: Easy De-calc
- Calc clean reminder

Safety Information

- This product meets the requirements regarding interference suppression on radio and TV.
- After the product has been repaired, it should function properly and has to meet the safety requirements and legal regulations as officially laid down at this moment.

TECHNICAL INFORMATION

Voltage	: 220 - 240 V
Frequency	: 50 - 60 Hz
Power	: 2400 W
Dimension (F-box)	: 362 (D) x 270 (W) x 263 (H) mm
Weight of iron	: 1 kg
Weight of iron + base	: 4.5 kg

Water Advice

Suitable for tap water use. Advice to mix with equal portion of distilled water or use only distilled water if the tap water is very hard.

Soleplate: Steam Glide

New SteamGlide soleplate is the best Philips soleplate. It has great scratch resistancy, glides excellent and is easy to clean.

OptimalTemp Technology

- Always deliver 1 perfect setting for all your clothes thanks to:
 1. Cylonic steam chamber
 2. Advance Smart control processor
- 100% easy to use, no adjustment required.
- 100% safe on all delicate fabrics.
- 100% fast on the toughest fabrics.

Tested and approved by experts

Tested and approved by independent textile experts institutes.

Steam pressure: Up to 5 bar

Double your ironing speed with pressurized steam.

2.2L fully visible water tank

Large water tank ensures long hours of ironing without refill of water tank.

Lock your iron securely

Lock your iron securely and carry your steam generator easily

Easy De-Calc

Easy De-Calc, hassle free & effective scale removal to extend the life of your steam generator.

DISASSEMBLY ADVICE - IRON

Light strip cap assy 1
Inlay and light strip assy 2
Reflector molded 3
LED microswitch holder assy 4
Trigger spring 5
Trigger molded 6
Mica plate 7
Plastic washer (1x) 8 (Front)
Decoration cap printed 9

Remove Screw A
Disassemble Light strip 1



Fig 1 Using "-" screw driver to lift up the Inlay and release the catch at the end of the handle

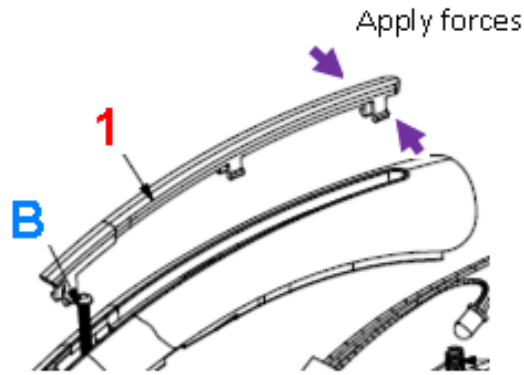

Fig 2 position of the catch to be applied forces

Remove Screw B
Disassemble Inlay and light strip assy 2
Disassemble Reflector molded 3
Remove Screw C
Disassemble LED microswitch holder assy 4
Disassemble Trigger spring 5
Disassemble Trigger molded 6
Remove Screw D
Disassemble Mica plate 7
Disassemble Plastic washer (1x) 8
Remove Screw E1 E2
Remove F
Disassemble Decoration cap printed 9

GC8651

Ryton ring 10
Deviator housing molded 11
Iron thermistor assy 12
Plstic washer (2x) 8 (Rear)
Hose cord mounted assy 14
Housing printed 15
Soleplate mounted assy 16

Remove Screw A
Disassemble Light strip 1
Remove Screw B
Disassemble Inlay and light strip assy 2
Disassemble Reflector molded 3
Remove Screw C
Remove Screw E1 E2
Remove Screw D
Disassemble Mica plate 7
Disassemble Plastic washer (1x) 8
Disassemble Ryton ring 10
Remove Screw G1 G2 G3 G4
Disassemble Deviator housing molded 11
Remove Screw H
Disassemble Iron thermistor assy 12
Remove Screw I1 I2
Disassemble Plastic washer (2x) 8
Disconnect Wires
Release hose clip (2x)
Remove J
Disconnect Wires
Disassemble Hose cord mounted assy 14
Disassemble Housing printed 15
Disassemble Soleplate mounted assy 16

Pos	Service Code	Description
1	423902170734	Light strip cap assy
2	423902170722	Inlay and light strip assy
3	423902649561	Reflector molded
4	423902171942	LED microswitch holder assy
5	423901454961	Trigger spring
6	423902649752	Trigger molded
7	423901012911	Mica plate
8	423902649501	Plastic washer
9	423902170741	Decoration cap printed
10	423901570153	Ryton ring
11	423902649491	Deviator housing molded
12	423902169942	Iron thermistor assy
14	423902170703	Hose cord mounted assy
15	423902170692	Housing printed
16	423902170651	Soleplate mounted assy

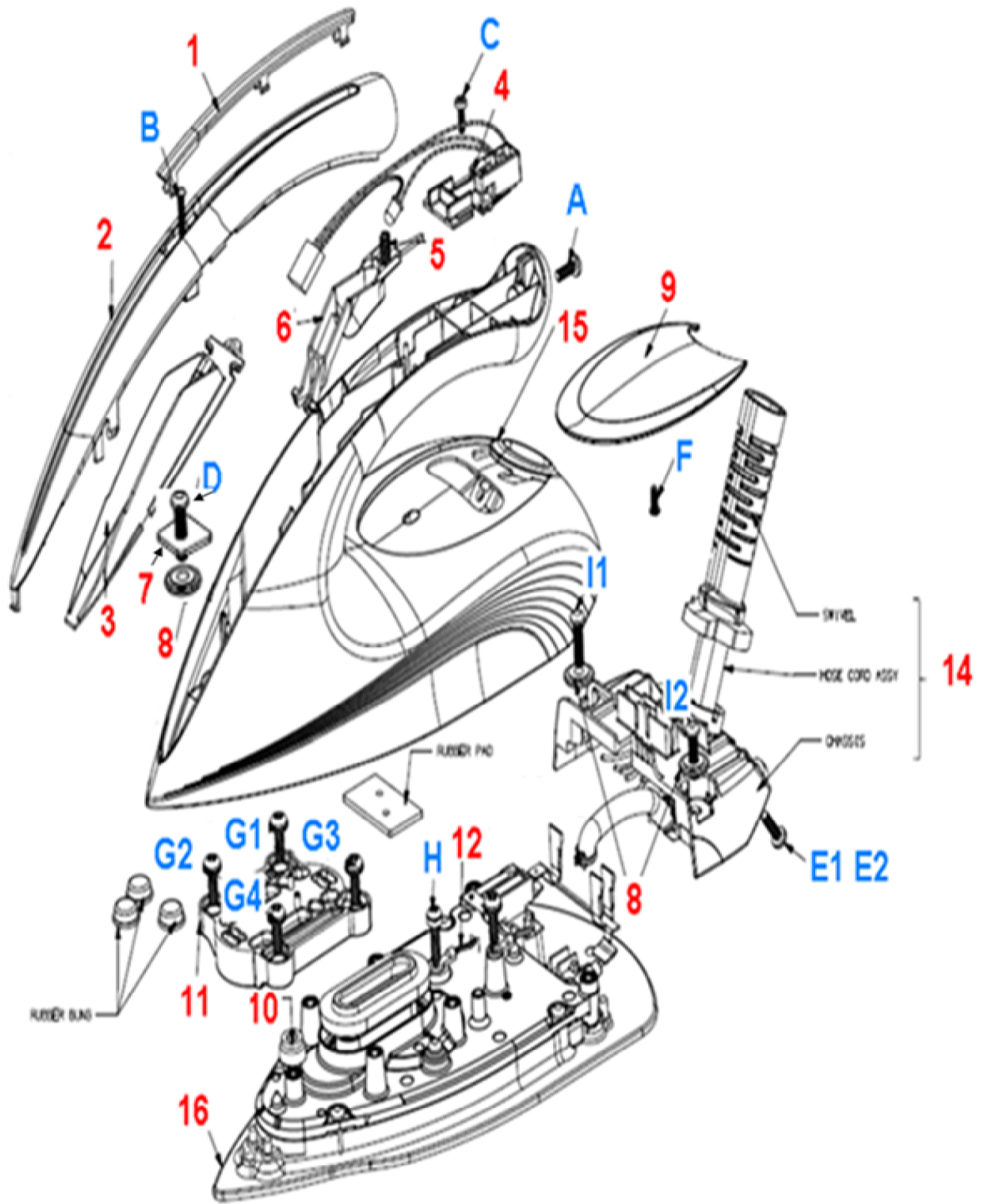

Filling door molded 17
Rear lock rubber 18
Tray rubber cap 19
Tray cap molded 20
Tray printed 21
Front lock assy 22
Water tank assy 23

- Disassemble **Filling door molded 17**
- Disassemble **Rear lock rubber 18**
- Remove **Tray rubber cap 19 (4x)**
- Remove **Screw K1 K2 K3 K4**
- Remove **Tray cap molded 20 (2x)**
- Remove **Screw L1 L2**
- Disassemble **Tray printed 21**
- Remove **Screw M1 M2**
- Disassemble **Front lock assy 22**
- Remove **Screw N1 N2 N3 N4 N5**
- Disassemble **Water tank assy 23**

Power button printed 37
Button frame printed 38
Power board PCB-Pump service kit 39
Power Cord EU 40
Stand bottom molded 41

- Remove **Screw N1 N2 N3 N4 N5**
- Disassemble **Water tank assy 23**
- Remove **Screw S1 S2 S3**
- Disassemble **Power button printed 37**
- Disassemble **Button frame printed 38**
- Remove **Screw T**
- Release **Inox clamp 26 (2x)**
- Disassemble **Braided rubber hose Boiler 27**
- Disconnect **Wires**
- Disassemble **Power board PCB-Pump service kit 39**
- Remove **Screw U1 U2**
- Disassemble **Cord clamp**
- Disassemble **Power Cord EU 40**
- Disassemble **Stand bottom molded 41**

Rinse cap assy 24
Safety cap 25
Inox clamp 26
Braided rubber hose Boiler 27
Electrovalve 28
Spacer top 29
Rinse housing cap printed 30
Rinse housing molded 31
O ring 32
Boiler assy 33
Boiler support bracket 34
Spacer bottom 35
Boiler thermistor assy 36

- Disassemble **Rinse cap assy 24**
- Remove **Screw N1 N2 N3 N4 N5**
- Disassemble **Water tank assy 23**
- Remove **Safety cap 25**
- Release **Inox clamp 26 (2x)**
- Disassemble **Braided rubber hose Boiler 27**
- Release **Hose clip**
- Disconnect **Wires**
- Disassemble **Electrovalve 28**
- Remove **Screw O1 O2 P**
- Remove **Spacer top 29**
- Remove **Screw Q**
- Disassemble **Rinse housing cap printed 30**
- Remove **Screw R**
- Disassemble **Rinse housing molded 31**
- Disassemble **O ring 32**
- Disassemble **Boiler assy 33**
- Disassemble **Boiler support bracket 34**
- Remove **Spacer bottom 35**
- Disassemble **Boiler thermistor assy 36**

Pos	Service Code	Description
17	423902649714	Filling door molded
18	423901559741	Rear lock rubber
19	423901559731	Tray rubber cap
20	423902651831	Tray cap molded
21	423902170802	Tray printed
22	423902170783	Front lock assy
23	423902170812	Water tank assy
24	423902171672	Rinse cap assy
25	423901559791	Safety cap
26	423901010261	Inox clamp
27	423901559771	Braided rubber hose Boiler
28	423901712802	Electrovalve
29	423902651241	Spacer top
30	423902172612	Rinse housing cap printed
31	423902649732	Rinse housing molded
32	423901559751	O ring
33	423902169891	Boiler assy
34	423902642581	Boiler support bracket
35	423902632181	Spacer bottom
36	423902169951	Boiler thermistor assy
37	423902170772	Power button printed
38	423902170762	Button frame printed
39	423902267101	Power board PCB-Pump service kit
40	242207098401	Power Cord EU
41	423902649592	Stand bottom molded

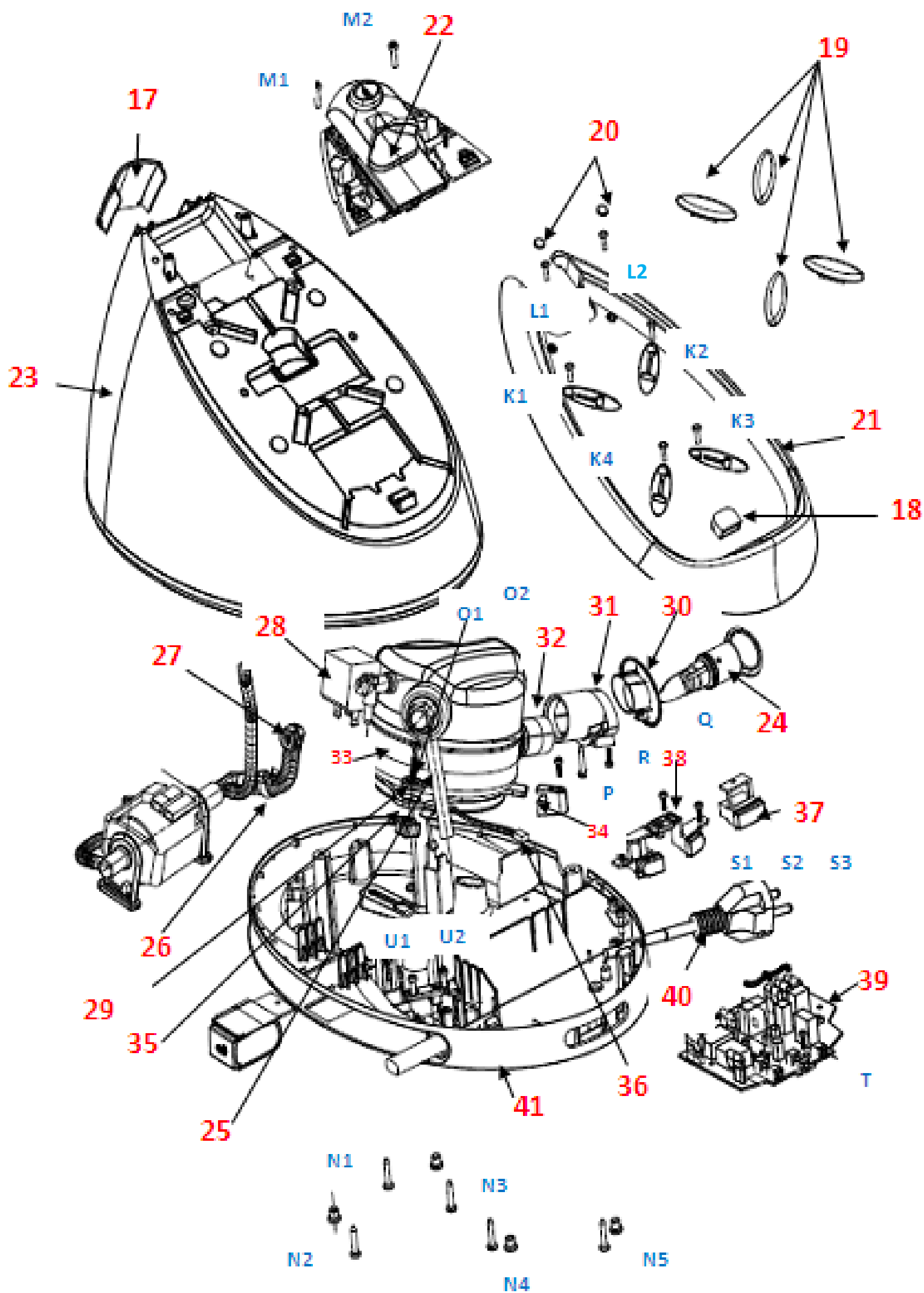

WIRING DIAGRAM

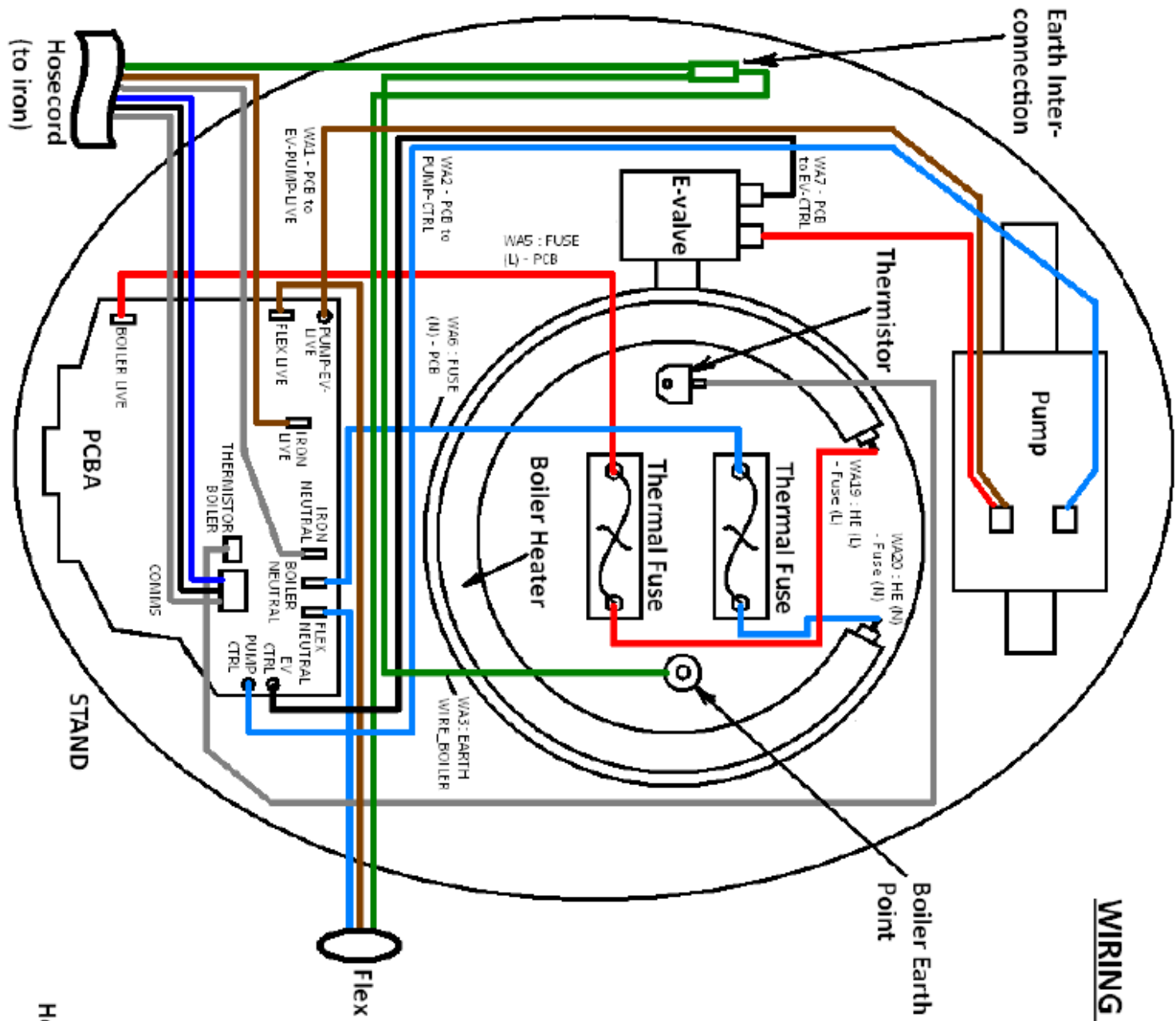

WIRING DIAGRAM

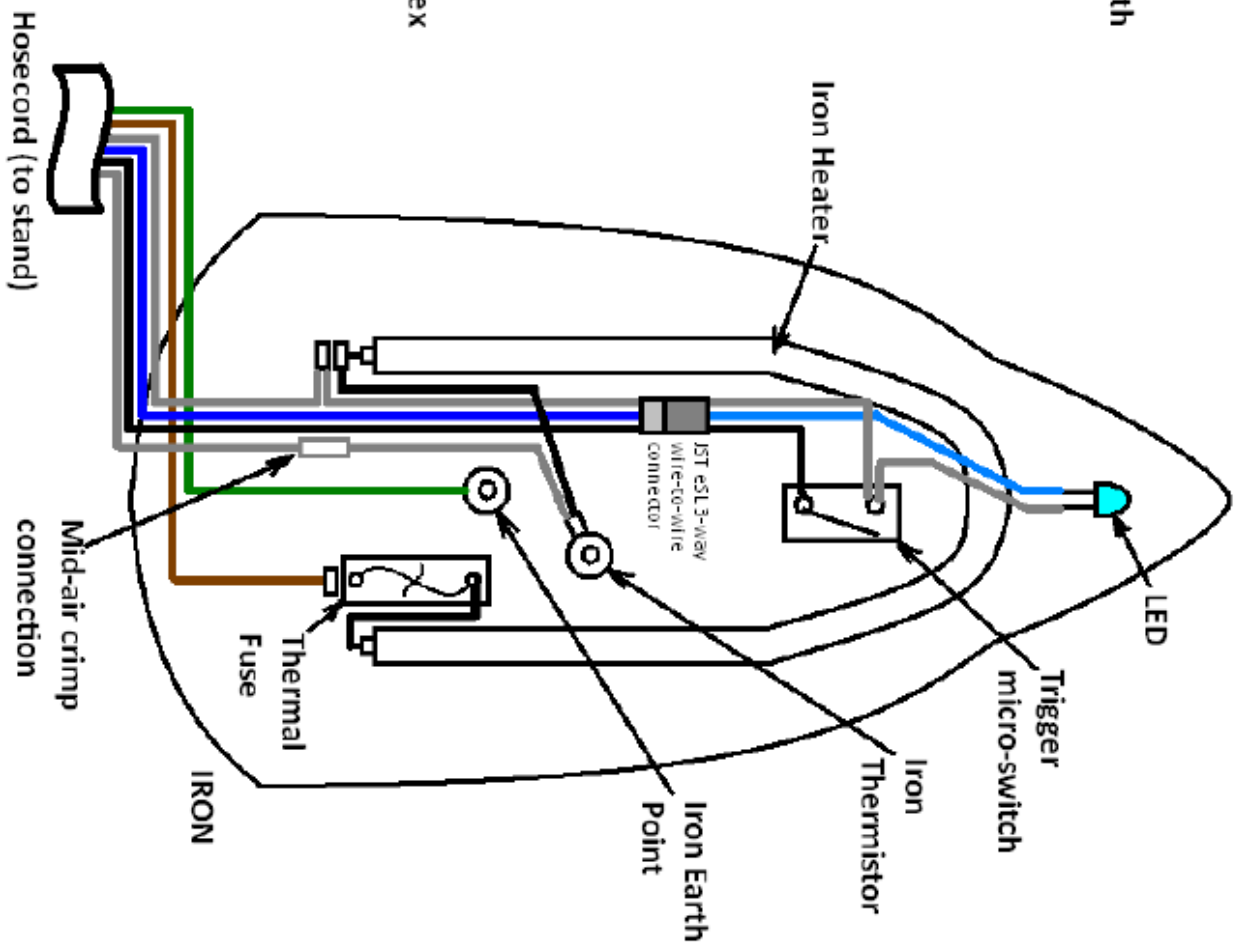

WIRING DIAGRAM

Due to the high wattage of the iron, only the specified cord set must be used.

- Should damage be observed on the **HOSE-CORD ASSY** or **CORDSET 14**, they must be replaced.

Continued usage is not allowed.

- When replacing the **MICROSWITCH ASSY 4**, please dress the 2 attached wires such that they are free of tension.

Pulling force on the wires may affect the steam triggering.

- To avoid damage to the sealing & components of the **BOILER ASSY 33**, **NEVER** clean the boiler assy with vinegar, descaling agent or other corrosive chemicals.

- When replacing **ELECTROVALVE 28** or **PUMP ASSY 39**, please be reminded to apply loctite at the joints for good sealing.

- After the product has been repaired, it should function properly and has to meet the safety requirements & legal regulations as laid down & officially established at this moment.

- The following tests are common checks that are conducted on a repaired product before it is returned to the consumer.

1. Soleplate temperature

Check that soleplate temperature is within IEC requirement.

Measure the temperature of the soleplate after the iron has reached steady state i.e connected to the mains for at least 15 minutes. The table below shows the temperature requirement.

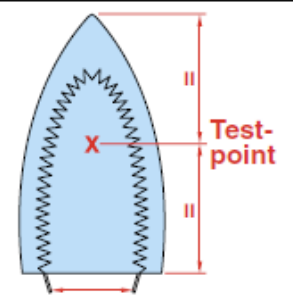
Soleplate temperature (Deg C)		Materials, for example	
Minimum	Maximum		
120	143	All fabric types	

2. Leakage current

Check that leakage current is within IEC requirement.

Measure leakage current between LIVE/NEUTRAL & EARTH.

IEC requirement is that at 230 V supply, the EARTH leakage current must be less than 0.75 mA.

3. Water leakage / Functionality

Check that there is no water leakage from any part of the product during operation.

Check that the functionality of the product (product dependent) eg. steaming, variable steam, SOS, ASO etc is working properly.

4. Loose part

Check that there are no loose parts eg. extra screw in the product that can cause short-circuit or product malfunction.