



Philips Consumer Lifestyle

Service Manual

Product information

Fast & powerful crease removal

- Soleplate: T-Ionic Glide
- OptimalTemp Technology
- Safe rest
- Silent Steam Technology
- Vertical steam
- Pressure: Up to 7.2 bar
- Variable steam settings
- Steam output control
- Steam tip
- Power: 2400 W
- Constant vertical steam
- Steam boost: 440 g
- Continuous steam output: 135 g/min

Easy to use

- Safe for all fabrics: Even for delicates like silks
- Water tank capacity: 1800 ml
- Filling and emptying water: Detachable water tank, Extra large filling hole
- Refill any time
- Heat-up time: 2 min
- Ultra light and comfortable
- Safety auto off
- Storage solution: Carry lock
- Cord freedom (swivel): 180 degree cord freedom
- Low water alarm
- Cord storage: Cord storage compartment

- Power cord length: 1.8 m
- Hose storage: hose storage compartment
- Hose length: 1.7 m
- Open handle

Sustainability

- ECO setting
- Energy saving: 50% energy reduction
- Warranty: 2 year(s)

Calc management

- Suitable for tap water
- Calc clean reminder
- Calc clean solution: Easy De-Calc Plus

Technical information

- Voltage : 220 - 240 V
- Dimensions:
 - Packaging : 31 x 35 x 51 cm
 - Product : 23.3 x 28.5 x 45.3 cm
- Weight:
 - Iron : 0.8 kg
 - Iron + Base : 5.1 kg

INLAY & LIGHT STRIP 1

MICROSWITCH & REFLECTOR ASSY 2

TRIGGER SPRING 4

TRIGGER 5

HOUSING CAP 6

HOUSING 8

- Remove **Screw A1**
- Remove **INLAY & LIGHT STRIP 1**
- Remove **Screw B1, B2, B3 & B4**
- Remove **MICRO SWITCH & REFLECTOR ASSY 2**
- Remove **TRIGGER SPRING 4**
- Remove **TRIGGER 5**
- Remove **HOUSING CAP 6**
- Remove **Screw C1**
- Remove **Screw D1 & D2**
- Remove **HOUSING 8**

GROMMET 7

CORD CLAMP 9

RUBBER BUNG 11 & RYTON RING 12

CHASSIS 10

SOLEPLATE ASSY 13

- Remove **Screw E1 & E2**
- Remove **GROMMET 7**
- Remove **Screw F1 & F2**
- Remove **CORD CLAMP 9**
- Disconnect **All wire connection**
- Remove **RUBBER BUNG 11**
- Remove **RYTON RING 12**
- Remove **Mica sheet**
- Remove **Screw G1, G2, G3 & G4**
- Remove **CHASSIS 10**
- Remove **SOLEPLATE ASSY 13**
- Remove **Screw H1**
- Remove **Thermistor**

FRONT LOCK SLIDER SPRING 16H

FRONT LOCK CATCH SPRING 16G

- Remove **Screw J1 - J5**
- Remove **Tray**
- Remove **FRONT LOCK SLIDER SPRING 16H**
- Remove **Lock assy**
- Remove **Screw K1, K2, K3 & K4**
- Remove **Front lock bracket**
- Remove **FRONT LOCK CATCH SPRING 16G**

UI POWER BOARD 23

BUTTON FRAME 24

POWER BUTTON 25

- Remove **TRAY 18**
- Remove **Screw L1, L2 & L3**
- Remove **IU BOARD PCBA 23**
- Remove **Screw M1 & M2**
- Remove **BUTTON FRAME 24**
- Remove **POWER BUTTON 25**

WATER TANK ASSY 15

TRAY RUBBER CAP 17

BUNG 51

STAND TOP 19

RETURN TUBE 29

- Remove **WATER TANK ASSY 15**
- Remove **TRAY RUBBER CAP 17**
- Remove **BUNG 51**
- Remove **Screw A1 - A10**
- Remove **STAND TOP 19**
- Remove **RETURN TUBE 29**

INLET SUPPORT SEAL 30

INLET SUPPORT PLATE 31

INLET COUPLING SUPPORT 32

- Remove **Screw B1 & B2**
- Remove **INLET SUPPORT SEAL 30**
- Remove **INLET COUPLING PLATE 31**
- Disconnect **Tube**
- Remove **INLET COUPLING SUPPORT 32**

POWER BOARD PCBA ASSY 20

PCBA HOLDER 21

HALL SENSOR PCBA ASSY 22

PUMP SUPPORT 28A & 18B

CORRUGATED ELBOW TUBE 27

BRAIDED RUBBER HOSE 33

PUMP ASSY 26

- Remove **Screw C1 - C5**
- Remove **POWER BOARD PCBA ASSY 20**
- Remove **PCBA HOLDER 21**
- Disconnect **All wire connection**
- Remove **HALL SENSOR PCBA ASSY 22**
- Remove **PUMP SUPPORT 28A & 18B**
- Remove **CORRUGATED ELBOW TUBE 27**
- Remove **Inox clamp**
- Remove **Hose clip**
- Remove **BRAIDED RUBBER HOSE 33**
- Remove **PUMP ASSY 26**

SAFETY CAP 38B

SAFETY VALVE 38A

E-VALVE 37

RINSE CAP ASSY 42

SPACER TOP 46

SPACER BOTTOM 47

BOILER ASSY 36

- Remove **SAFETY CAP 38B**
- Remove **SAFETY VALVE 38A**
- Remove **E-VALVE 37**
- Remove **Hose clip**
- Remove **BRAIDED RUBBER HOSE 33**
- Remove **Screw D1 - D5**
- Remove **RINSE CAP 42**
- Remove **SPACER TOP 46**
- Remove **SPACER BOTTOM 47**
- Remove **BOILER ASSY 36**

CLAMPING PLATE 45

CORD SET 43

CORD CLAMP 44

HOSE CORD MTD ASSY 14

BELT LOOP LEFT 49 & RIGHT 48

STAND BOTTOM 50

- Remove **Screw E1 & E2**
- Remove **CLAMPING PLATE 45**
- Remove **CORD SET 43**
- Remove **Screw F1 & F2**
- Remove **CORD CLAMP 44**
- Remove **HOSE CORD MTD ASSY 14**
- Remove **Screw G1, G2 & G3**
- Remove **BELT LOOP LEFT 49**
- Remove **Screw H1, H2 & H3**
- Remove **BELT LOOP RIGHT 48**
- Remove **STAND BOTTOM 50**

Pos	Service code	Description
1	4239 021 88451	Inlay & Light strip
2	4239 026 61311	Reflector assy
3	4239 021 87002	LED wire assy
4	4239 014 55381	Trigger spring
5	4239 026 61911	Trigger
6	4239 015 61511	Housing cap
8	4239 021 88581	Housing & Deco plate
10	4239 026 61291	Chassis
11	4239 015 59781	Rubber bung
12	4239 015 70153	Ryton ring
13	4239 021 86871	Soleplate Mtd assy
14	4239 021 88592	Hose cord Mtd assy

Pos	Service code	Description
15	4239 021 88631	Water tank assy
16G	4239 014 55091	Front lock catch spring
16H	4239 014 55011	Front lock slider spring
17	4239 015 59731	Tray rubber cap
18B	4239 015 61641	Pump support outlet
19	4239 021 88851	Stand top
19A		Tray
19B		Front Lock assy
19C		Stand top molded
20	4239 021 87372	Power board PCBA assy
21	4239 026 61591	PCBA holder
22	4239 021 87391	Hall sensor PCBA assy
23	4239 021 87382	IU board PCBA assy
24	4239 021 88481	Button frame
25	4239 021 88491	Power button
26	4239 021 86591	Pump assy
27	4239 015 61551	Corrugated elbow tube
28A	4239 015 61631	Pump support inlet
29	4239 015 59321	Return tube
30	4239 015 61571	Inlet support seal
31	4239 021 88461	Inlet coupling plate
32	4239 026 61601	Inlet coupling support
33	4239 015 61381	Braided rubber hose
34	4239 010 10281	Hose clip
35	4239 010 10261	Inox clamp
36	4239 010 14061	Boiler assy (1700 W)
37	4239 010 13831	E-valve (7 bar)
38A	4239 010 13821	Safety valve (8 bar)
38B	4239 015 59211	Safety cap Nat
39	4239 021 86971	Water probe assy
40	4239 026 42581	Boiler support bracket
41	4239 015 70153	Ryton ring (Boiler)
42	4239 021 88391	Rinse cap assy
43	2422 070 98592	Cordset (EU)
44	4239 026 26273	Cord clamp
45	4239 010 00283	Clamping plate
46	4239 026 51241	Spacer top
47	4239 026 32181	Spacer bottom
50	4239 021 88611	Stand bottom assy
51	4239 015 52342	Bung

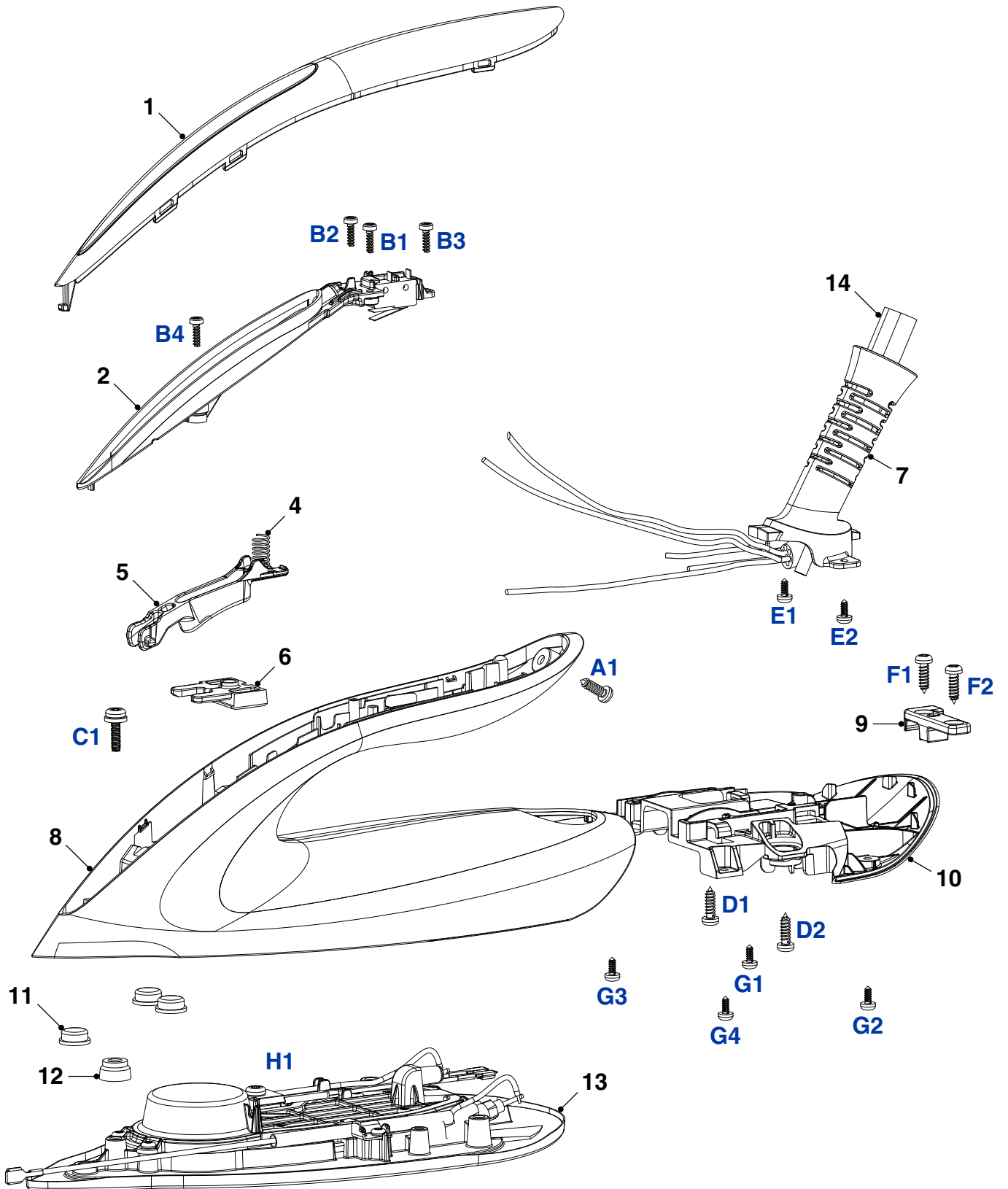

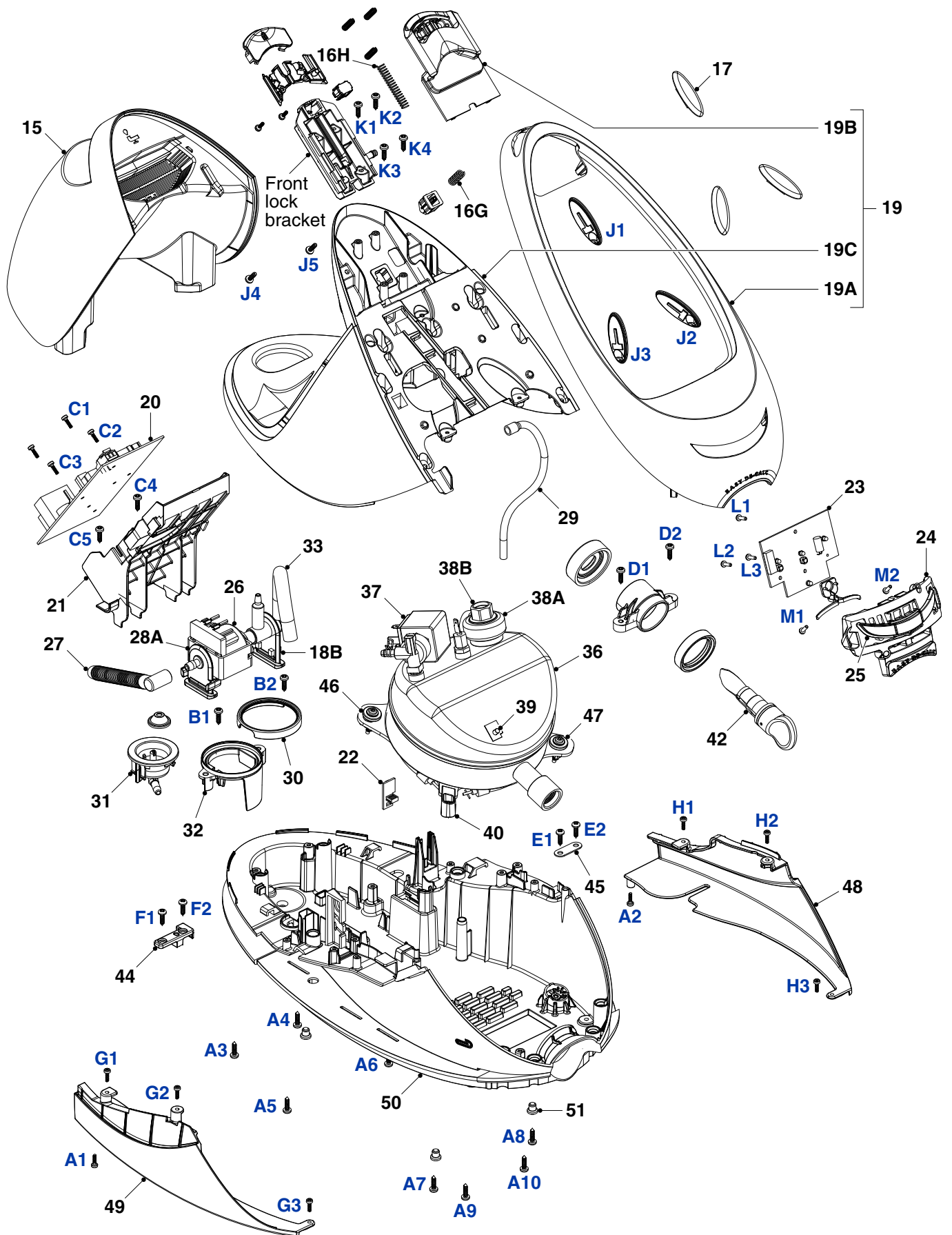

Wiring Diagram

GC9642

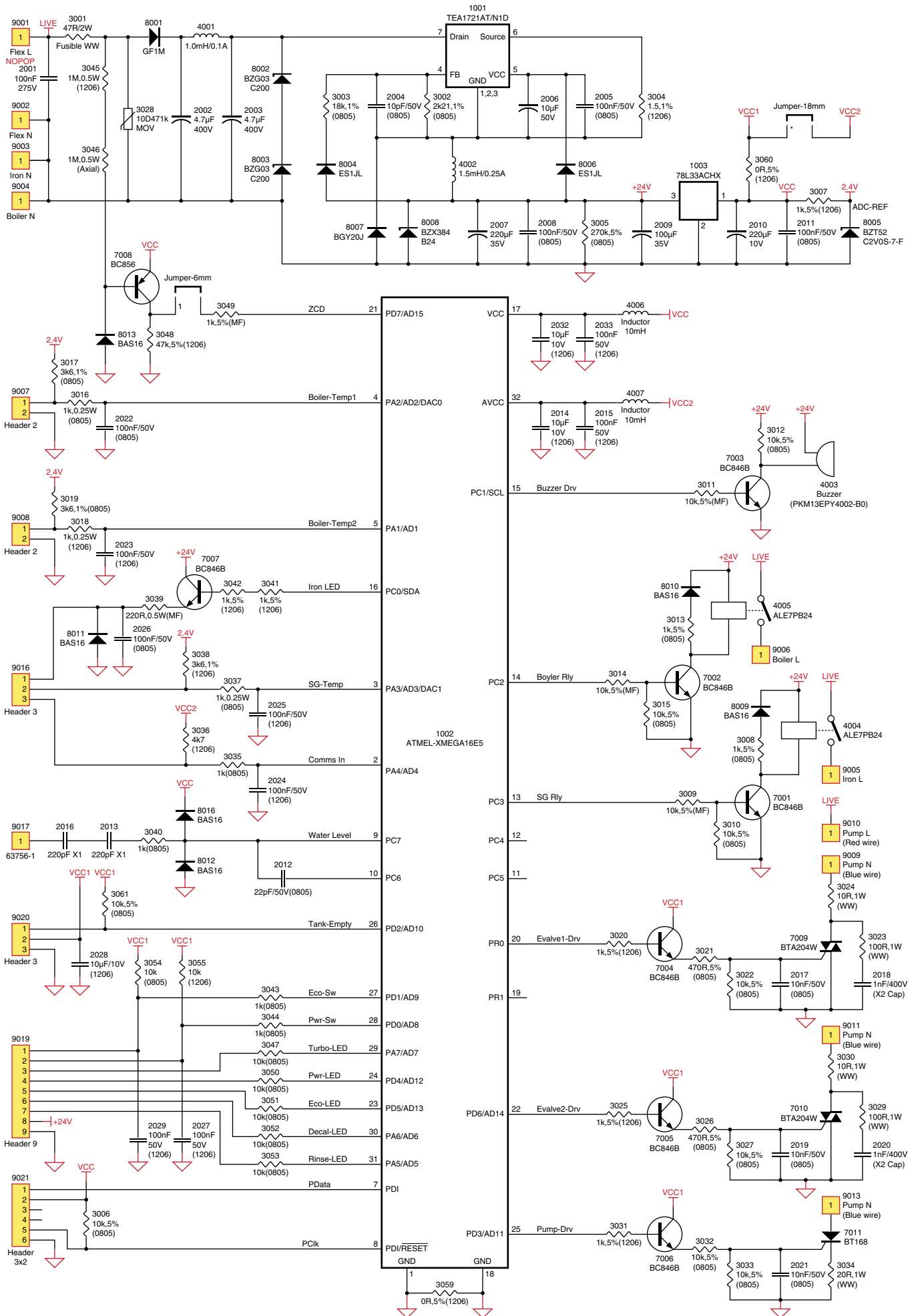

- Due to the high wattage of the iron, only the specified cord set must be used.
- Should damage be observed on the **CORDSET 43**, it must be replaced. Continued usage is not allowed.
- If **STAND BOTTOM ASSY 50** is provided without type plate information eg. Type number, voltage etc. When replacing the Stand Bottom Assy, engrave the type number & voltage on the type plate with a sharp object.
- After the product has been repaired, it should function properly and has to meet the safety requirements & legal regulation as laid down & officially established at this moment.
- The following tests are common checks that are conducted on a repaired product before it is returned to the consumer.

1. Soleplate temperature

Check the soleplate temperature is within IEC requirement.

Soleplate temperature (Deg C)		Materials, for example	
Minimum	Maximum		
120	143	All fabric types	

2. Leakage current

Check that leakage current is within IEC requirement.

Measure leakage current between LIVE/NEUTRAL & EARTH.

IEC requirement is that at 230 V supply, the EARTH leakage current must be less than 0.75 mA.

3. Water leakage / Functionality

Check that there is no water leakage from any part of product during operation.

Check that the functionality of the product (product dependent) eg. Steaming, variable steam, SOS, ASO etc is working properly.

4. Loose part

Check that there are no loose parts eg. Extra screws in the product that can cause short-circuit or product malfunctions.

5. Fuse open circuit

When replacing fuse, to also service the water tubes which is probably choked with calc.

6. Self-Check mode

6.1. Introduction of Self-Check mode

Self-Check mode is **NOT** an exhaustive diagnosis, but a quick preliminary check on all the hardware function. Further test and troubleshooting may still be required by Service Center to identify the root cause.

6.2. Before start Self-Check mode, please do the following checking

1. Make sure Soleplate is cold (<100 °C)
2. Make sure Boiler is cold (<100 °C)
3. Make sure Boiler is empty
4. Water tank with water above min mark
5. Water tank is NOT attached to the system
6. Power meter in place to monitor system power

6.3. Enter Self Check Mode Process Flow Chart

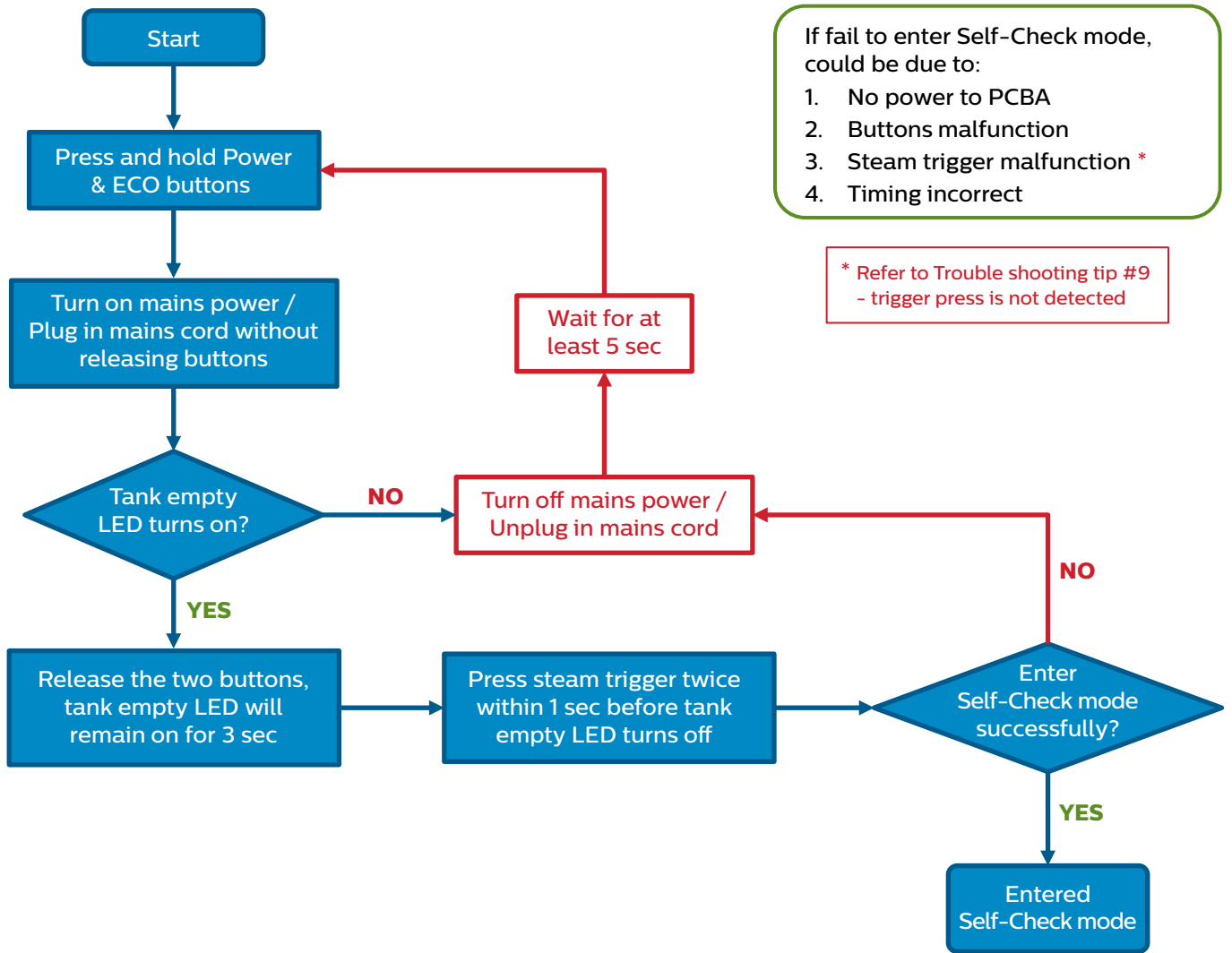

6.4 Perform Self-Check mode Process Flow Chart

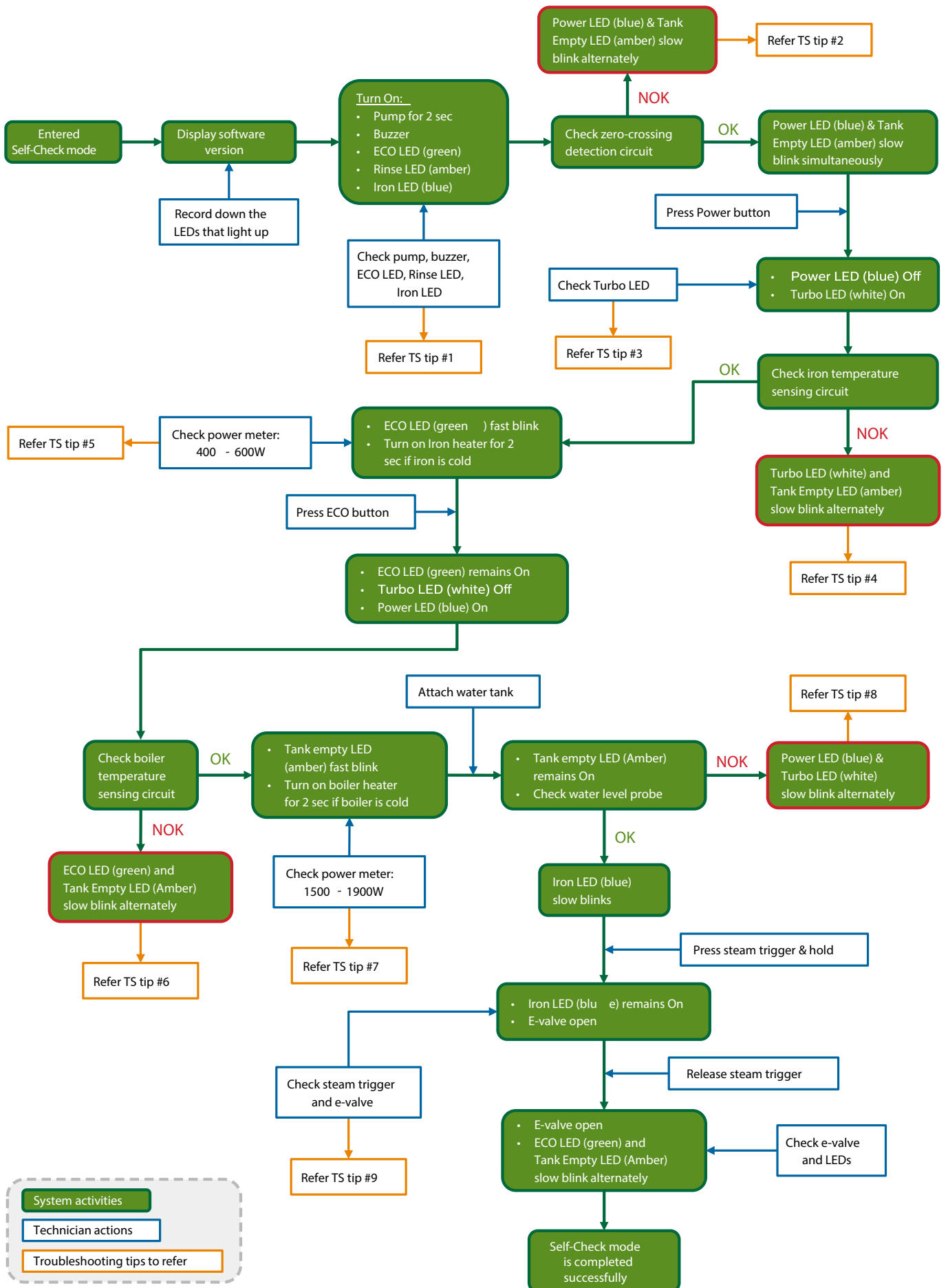

6.5. Troubleshooting Tips

1. No pumping sound, fault could be on: TS tip #1

- a) Pump → [check by apply AC voltage directly](#)
- b) **Power PCBA** → [check by driving a known good pump](#)
- c) Connection → [check wire continuity](#)

2. No buzzer sound, fault should be on Power **PCBA**

3. Iron LED does not light up as specified, fault could be on:

- a) Iron LED and hose cord wiring → [disconnect connector 9016 from Power PCBA and measure across pin 3 at female side and iron Neutral to check diode characteristics](#)
- b) Power PCBA → [check by test another board](#)

4. Other LEDs do not light up as specified, fault should be on one of **PCBAs or interconnection**

1. Zero-crossing detection circuit error, fault should be on **PCBA** TS tip #2

1. LEDs do not light up as specified, fault should be on one of **PCBAs or interconnection** TS tip #3

1. Iron temperature sensing circuit error, fault could be on: TS tip #4

- a) Thermistor → [check the resistance, should be around 200+ kΩ](#)
- b) Power PCBA → [check by test another board](#)
- c) Connection → [check wire continuity, especially hose cord](#)

1. Iron heater power does not show in the power meter, fault could be due to: TS tip #5

- a) Iron is too hot → [cool down and try again](#)
- b) Iron fuse or heating element Open Circuit → [check resistance between Iron Live and Neutral signal](#)
- c) Power PCBA → [check by test another board](#)

1. Boiler temperature sensing circuit error, fault could be due to: TS tip #6

- a) Thermistor → [check the resistance, should be around 200+ kΩ](#)
- b) Power PCBA → [check by test another board](#)
- c) Connection → [check wire continuity](#)

1. Boiler heater power does not show in the power meter, fault could be due to: TS tip #7

- a) Boiler is too hot → [cool down and try again](#)
- b) Boiler fuse or heating element Open Circuit → [check resistance between Boiler Live and Neutral signal](#)
- c) Power PCBA → [check by test another board](#)

1. Water probe error, fault could be due to: TS tip #8

- a) There is water inside boiler → [pour out water and test again](#)
- b) Probe reaches end of life → [replace probe and test again](#)
- c) Connection → [check wire continuity](#)
- d) Power PCBA → [check by test another board](#)

1. E-valve does not open when steam trigger is pressed: TS tip #9

- If iron LED still keeps blinking, trigger press is not detected, fault could be on:
 - a) Trigger mechanism or hose cord connection → [disconnect connector 9016 from Power PCBA and measure continuity between the black wire \(pin1\) and iron Neutral, it should be short circuit when trigger is pressed, and open circuit when trigger is released.](#)
 - b) Power PCBA → [check by test another board](#)
- If iron LED becomes steady on when press steam trigger, and system shows completed Self-Check mode successfully after release the trigger → [check E-valve related parts and Power PCBA](#)

7. Lock assy disassembly advise

Step 1: Use a screw driver to lift up the spring in the lock assy.

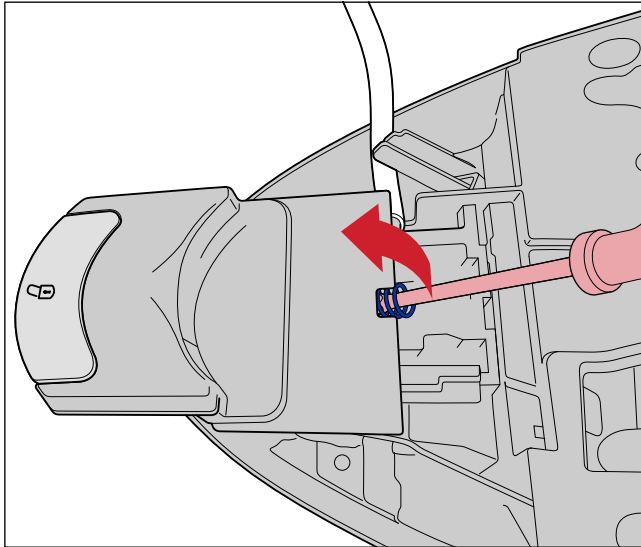

Step 2: Remove the lifted spring.

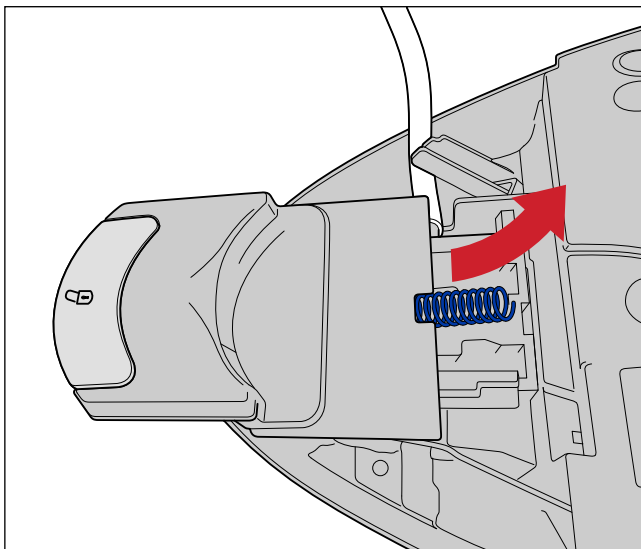

Step 3: Slide and lift up the lock assy.

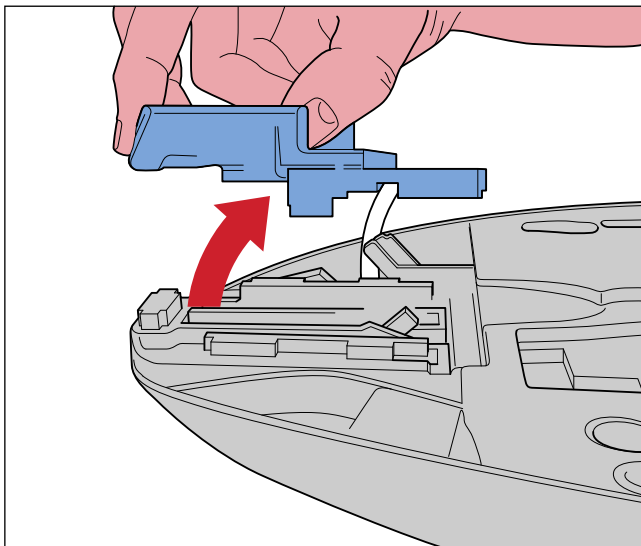

8. History Record

Added in Section 6 under Repair instruction on Aug

Revised Section 6, added in Section 8 under Repair instruction on Oct