



Philips Consumer Lifestyle

# Service Manual

## PRODUCT INFORMATION

### Safety Information

- This product meets the requirements regarding interference suppression on radio & TV.
- After the product has been repaired, it should function properly and has to meet the safety requirements & legal regulations as laid down & officially established at this moment.

### Features

#### Iron

- Optimal TEMP Iron
- Power on button
- Suction & blowing button for active board
- Steam trigger
- Auto shut off in 10 minutes
- Iron ready in 2 minutes
- Iron hose cord 1.6 m
- Steam rate 120 g/min

### Ironing Board

- Board cover
- Active & passive boards (Longer portion is the Active board)
- Unique board with one end especially for shirts
- Bi-directional fan on Active board for blowing & suction
- Board tilting mechanism
- Board folding & locking strap for storage & transport
- Height adjustment for board 0.75 m to 1.00 m in 21 intermediate steps
- Rod hanger for steamer mode

### Stand

- Automatic calc-cleaning system (3 minutes to complete)
- Detachable water tank with anti-calc cartridge (1.6 L capacity)
- Boiler up to 6.0 bar pressure
- Heat resistant storage compartment for iron
- Automatic cord-winder 2.5 m effective length
- Wheels for ease of mobility
- Detachable rinse tank 0.75 L
- Standby lamp : Green
- Auto Calc Clean lamp : Blue
- Replace Cartridge lamp : Red
- Water tank lamp : Red
- Rinse tank lamp : Red

- Power Maximum : 2300 W at 230 V, 10 A
  - Boiler : 1370 W
  - Iron : 800 W
  - Fan : 40 W
- Voltage : 230 V
- Frequency : 50 - 60 Hz
- Weight (product) : 20 kg
- Weight (with package) : 24 kg
- Product dimensions : 46.6 x 46.7 x 79.7 cm (L x W x H) in storage mode

**Start-up time**

Approximate 2 mins

Approximate 5 mins if automatic calc-cleaning is activated

**Anti-Calc Cartridge**

The anti-calc cartridge in the water tank removes calc from the water, hence preventing calc from building up in the system.

1 cartridge can effectively treat up to 14 full tanks of water before depletion. This is approximately 3 months of usage for a light or moderate user.

Replace the anti-calc cartridge when the red REPLACE CARTRIDGE light is on.

**Active ironing board**

The ironing board has 2 portions: Passive & Active board. The longer portion is the Active board. The Active board is specially shaped for shirt or blouse during ironing. It also has a bi-directional fan that offers suction or blowing during use. For optimized performance of the appliance, fan is permanently on during use.

**Auto Calc Cleaning System**

When the Auto Calc Clean process is activated, the blue Auto Calc Clean light blinks and there will be beeping sounds. This process takes place for ~3min. During this time, it is normal to hear pumping and clicking sounds from the system.

After ~3 min, rinse water is flushed into the rinse tank below, the beeping becomes faster and the red light blinks on the rinse tank. Pull out the rinse tank & empty its content into the sink. Put back rinse tank in place, the beeping and the red light blinking will stop.

The Auto Calc Clean process is now completed.

The green power-on light will come on.

The appliance will heat up and steam is ready for use in ~2 min.

The Auto Calc Clean process is automatically activated the first time you use the iron after you replaced the anti-calc cartridge

**Optimal TEMP Iron**

The iron is preset with the perfect combination of steam & temperature on all fabrics with:

- Cyclonic steam chamber
- Smart control processor
  - With perfect combination of steam & temperature,
- No adjustment is required.
- Safe on all delicate fabrics.
- Fast & effective on the toughest fabrics.

**BACKPLATE ASSY 13**

**HOSE CORD IRON 12**

- Disassemble **BACKPLATE SCREW CAP 20**
- Remove **Screw A1, A2**
- Disassemble **BACKPLATE ASSY 13**
- Disassemble **HOSE CORD IRON 12**

**INLAY MOLDED 14**

**IRON ELECTRONICS 21**

**HOUSING & LENS ASSY PRINTED 9**

- Disassemble **DECO RING SPRAYED 15**

*Tip:*  
Carefully insert a sharp object into the gap at the side & slowly lift up the part.

- Remove **Screw B**
- Disassemble **INLAY MOLDED 14**
- Disassemble **IRON ELECTRONICS 21**
- Remove **Screw C**
- Disassemble **HOUSING & LENS ASSY PRINTED 9**

**COVER MOLDED 8**

**SOLEPLATE MOUNTED ASSY 2**

**DEVIATOR HOUSING 4**

- Remove **Screw D1 - D3**
- Disassemble **COVER MOLDED 8**
- Disassemble **SOLEPLATE MOUNTED ASSY 2**
- Remove **Screw E1 - E6**
- Disassemble **DEVIATOR HOUSING 4**

**PARTS LIST - IRON ASSY**

Pos	Service code	Description
1	4239 020 03021	Iron assy
2	4239 021 61371	Soleplate mounted assy
3	4239 021 62051	Thermistor assy Iron
4	4239 026 43111	Deviator housing
5	4239 015 59151	Braided rubber hose Iron
6	4239 010 10281	Hose clip - Braided rubber hose
7	4239 015 70153	Ryton ring
8	4239 026 43121	Cover molded
9	4239 021 62122	Housing & lens assy printed
10	4239 026 42441	Light guide molded
11	4239 021 64461	Deco plate & top cover assy printed
12	4239 021 62852	Hose cord Iron
13	4239 021 62192	Backplate assy
14	4239 026 42911	Inlay molded
15	4239 021 63221	Deco ring sprayed
16	4239 026 43201	Button - Suction
17	4239 026 43211	Button - Blow
18	4239 026 43222	Button - Power
19	4239 026 46542	Trigger
20	4239 026 43161	Backplate screw cap
21	4239 021 62161	Iron electronics
22	4239 015 59361	Rubber bung

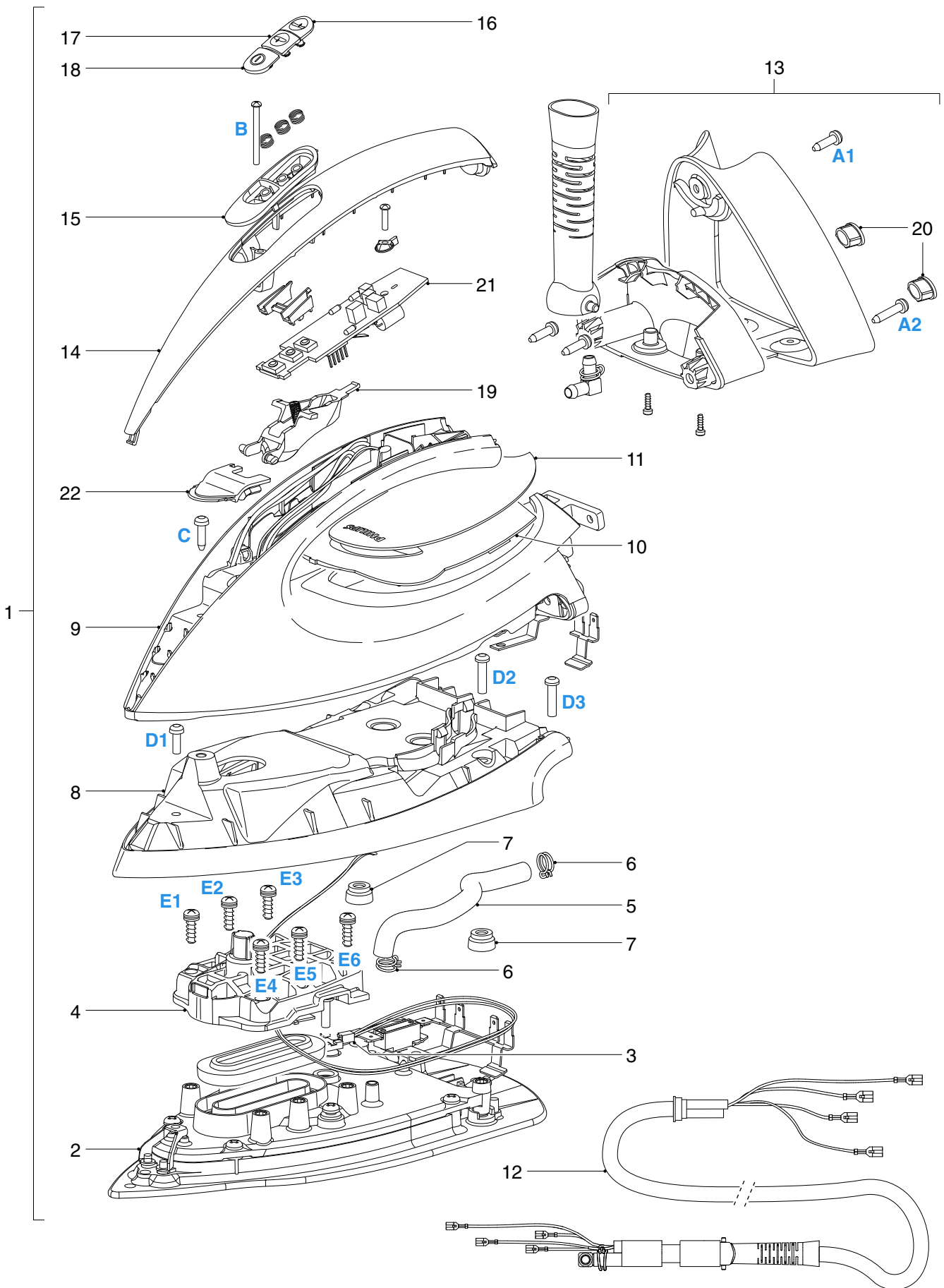

**WHEEL ASSY 44**

**CAP ASSY 46**

**E-RING 45**

- Disassemble CAP WHEEL 46
- Disassemble E-RING 45
- Disassemble WHEEL ASSY 44

**BACK COVER TOP 53**

**BACK COVER BOTTOM 54**

**AUTO CORD WINDER 48**

- Remove screws F1 - F4
- Disassemble BACK COVER TOP 53
- Remove screws G1 - G6
- Disassemble BACK COVER BOTTOM 54
- Remove screws H1 - H3
- Disconnect quick-connectors E, L, N, at the back of AUTO CORD WINDER 48
- Disassemble AUTO CORD WINDER 48

**SPRING LIFT COLUMN ASSY 42**

- Remove IRONING BOARD-MOVING COLUMN assy (refer DISASSEMBLY ADVICE-MOVING COLUMN)
- Remove screws J1 - J2
- Disassemble SPRING LIFT COLUMN ASSY 42

**PANEL LEFT ASSY 50**

**PANEL RIGHT ASSY 51**

**STAND ELECTRONICS 57**

**SMPS ELECTRONICS 58**

**COVER COMPLARTMENT BOILER 41**

- Remove screws K1 - K12
- Disassemble PANEL LEFT ASSY 50
- Disassemble PANEL RIGHT ASSY 51
- Disassemble COVER COMPARTMENT BOILER 41
- Remove screw L
- Disassemble SMPS ELECTRONICS 58
- Remove screw M
- Disassemble STAND ELECTRONICS 57

**RINSE TANK ASSY 56**

**FOOT ASSY 43**

**PANEL FRONT BOTTOM 52**

**CHASSIS BOILER ASSY 23**

**PUMP ASSY 32**

**ELECRO VAVLE 27**

**RINSE VAVLE 29**

- Remove RINSE TANK ASSY 56
- Remove screws N1 - N4
- Disassemble FOOT ASSY 43
- Remove screws P1 - P2
- Disassemble PANEL FRONT BOTTOM 52
- Remove screws a1 & a2 (Refer below picture)
- Remove 2x catches at the Boiler chassis

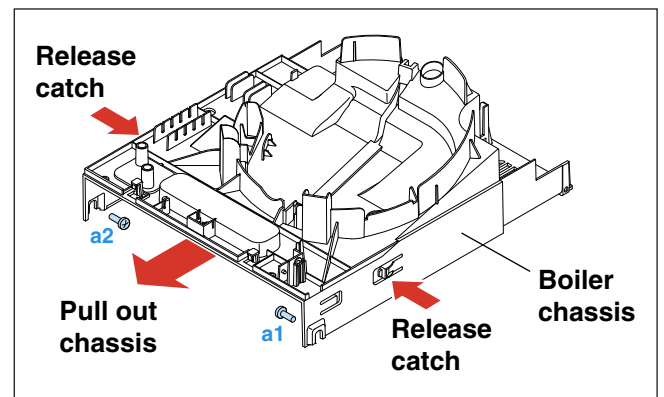

- Pull out CHASSIS BOILER ASSY 23
- Disassemble PUMP ASSY 32
- Disassemble ELECTRO VALVE 27
- Disassemble RINSE VALVE 29

**WATER SOCKET 37**

**MD WC SEALING 38**

- Remove screw Q
- Disassemble WATER SOCKET 37
- Disassemble MD WC SEALING 38

Pos	Service code	Description
23	4239 020 03011	Chassis boiler assy
24	4239 016 81880	Strap
25	4239 017 12361	Wire assy LED - Rinse tank
26	4239 017 12371	Wire assy - Rinse tank switch
27	4239 017 09890	Electro valve
28	4239 010 09442	Electro valve mesh
29	4239 017 12542	Rinse valve
30	4239 010 11101	Rinse valve mesh
31	4239 017 76171	Boiler thermistor
32	4239 021 64841	Pump assy
33	4239 026 42081	De-air valve
34	4239 015 56281	Braided rubber hose Boiler
35	4239 010 10261	Inox clamp
36	4239 017 12381	Wire assy LED - Standby and ACC
37	4239 026 35712	Water socket
38	4222 249 04571	MD WC sealing
39	4239 017 12351	Wire assy LED - Water tank
40	4239 017 12391	Wire assy LED - Calc cartridge
41	4239 026 32903	Cover compartment Boiler
42	4239 021 33840	Spring lift column assy
43	4239 021 49652	Foot assy
44	4239 021 49672	Wheel assy
45	4239 016 81890	E-ring ID 10
46	4239 026 34792	Cap wheel
47	4239 017 76161	Water tank reed switch assy
48	4239 021 65881	Auto cord winder Swiss
	4239 021 43313	Auto cord winder EU
49	4239 021 49592	Steamer door Hot foiled
50	4239 021 49603	Panel left assy
51	4239 021 49613	Panel right assy
52	4239 026 32992	Panel front bottom
53	4239 026 33002	Back cover Top
54	4239 026 33052	Back cover Bottom
55	4239 021 49624	Water tank assy
56	4239 021 49423	Rinse tank assy
57	4239 021 62171	Stand electronics
58	4239 021 62861	SMPS electronics
59	4239 021 62871	Sensing probe assy
60	4239 015 59341	Guide soleplate
61	4239 021 82931	Cartridge Blue pack assy

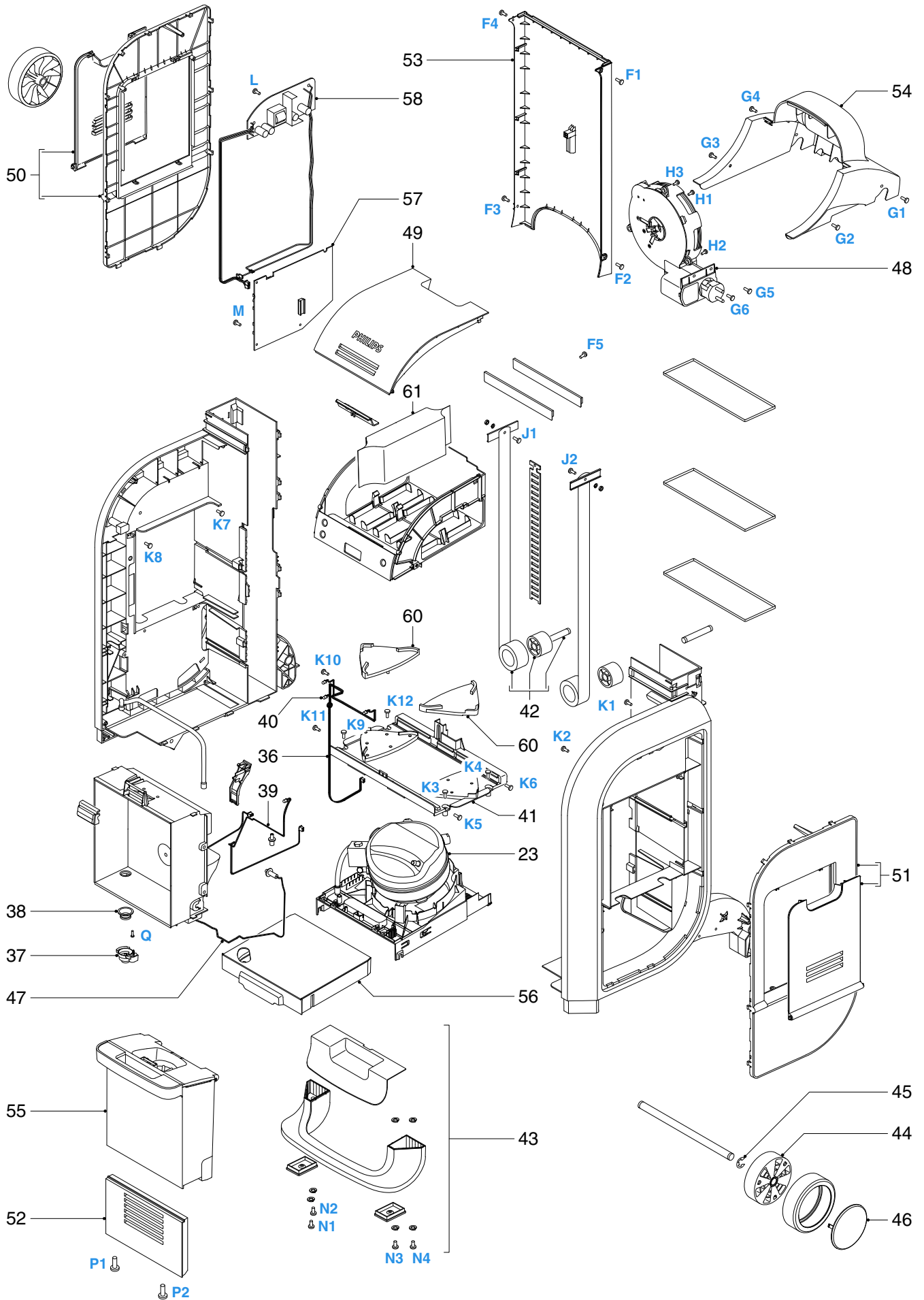

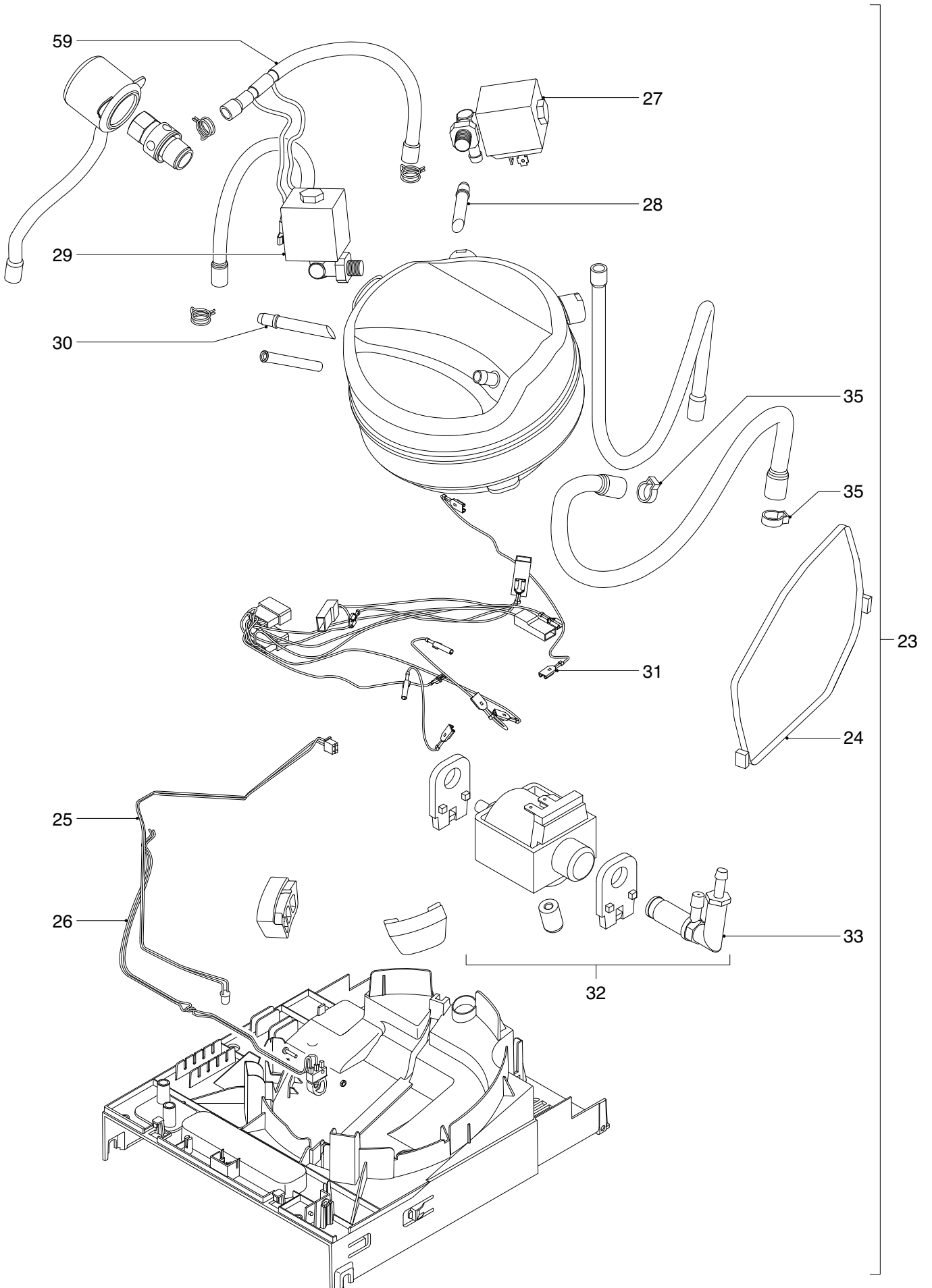



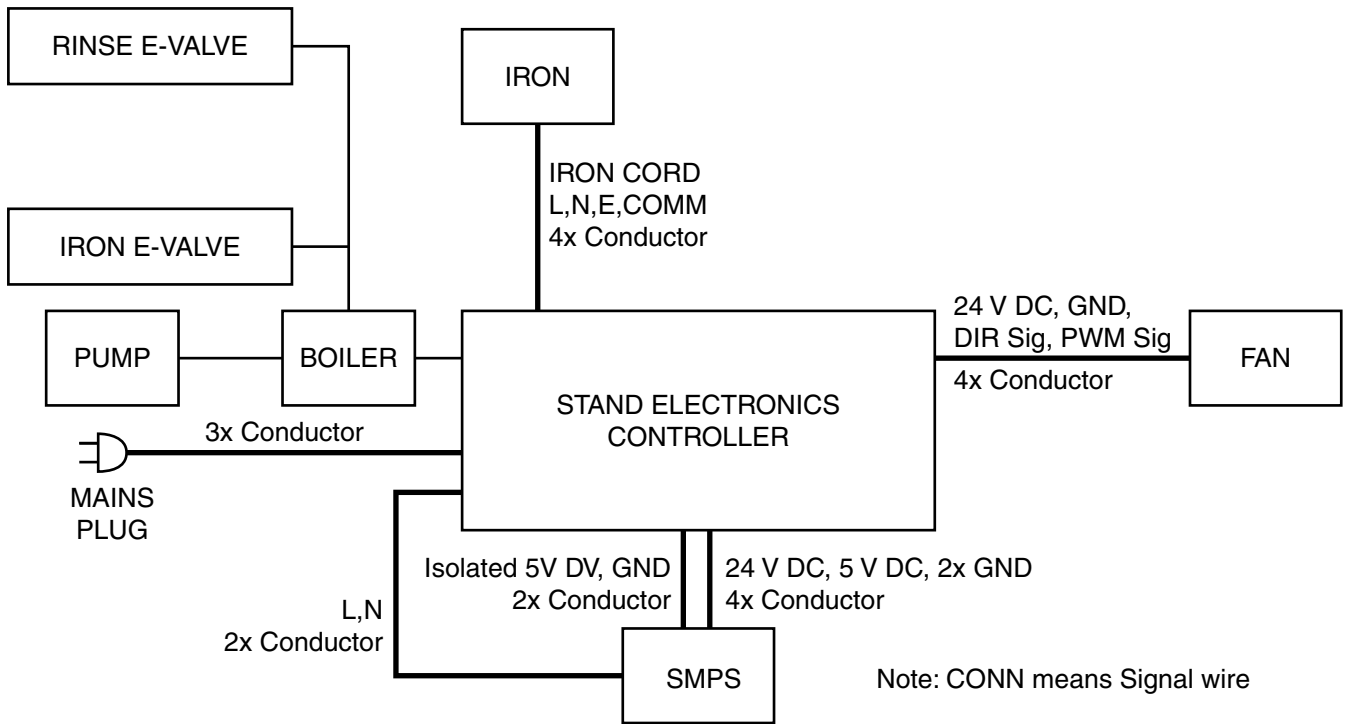

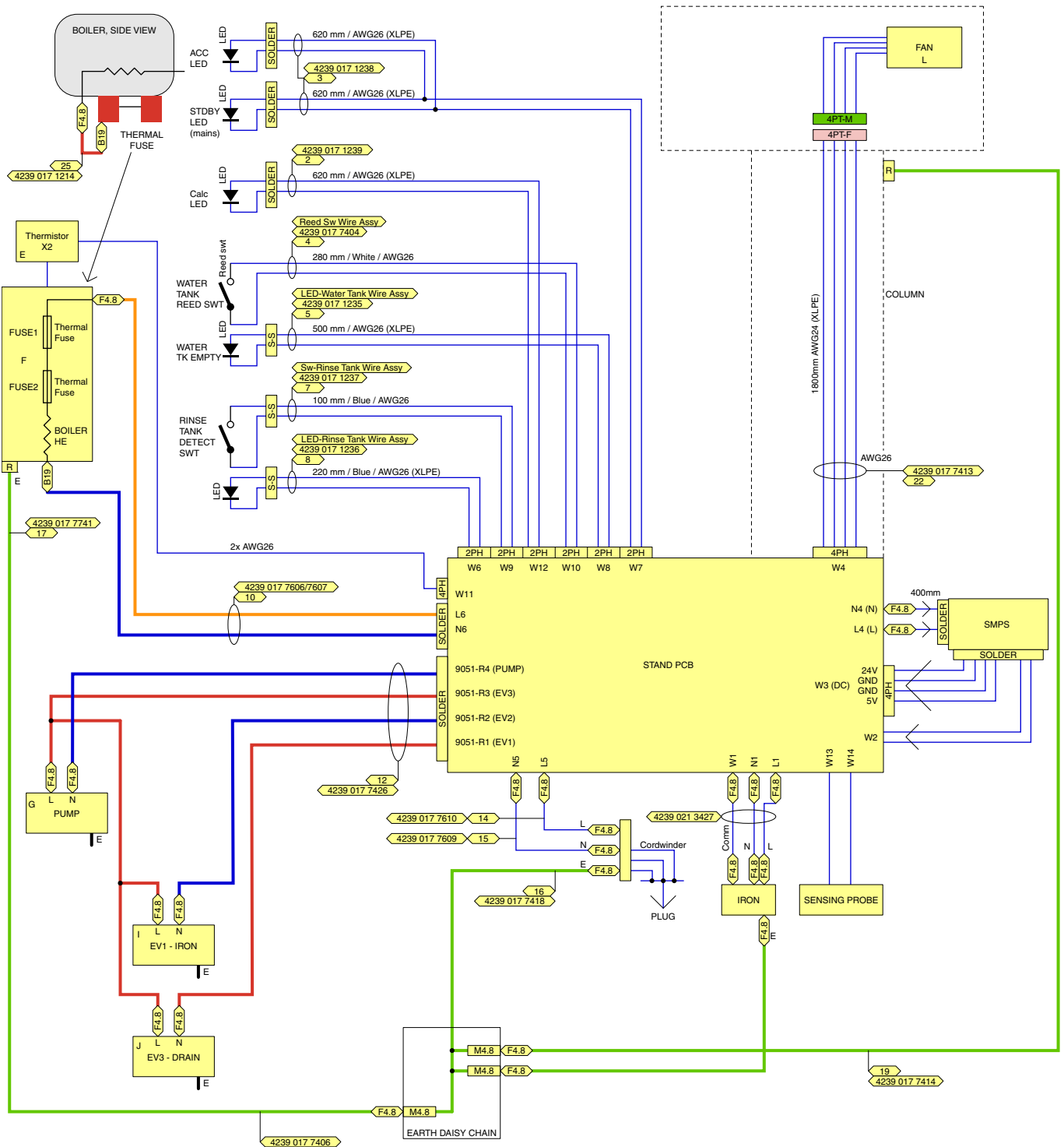

- LEGEND**
- 2PH 2P HEADER (JST XHP-2)
  - 4PH 4P HEADER (JST XHP-2)
  - SOLDER Directly soldered to PCB
  - F4.8 Female faston connector 4.8
  - B17 Stocko ID1.7 Pin receptable RBB8000R1.7-0.5
  - B19 Stocko ID1.9 Pin receptable RBB 7854.001 R1.9
  - 4P M 4-pole plug AMP 770275-1 (Male)
  - 4P F 4-pole receptable AMP 770274-1 (Female)
  - 3P M 3-pole plug AMP 770331-1 (Male)
  - 3P F 3-pole receptable AMP 770333-1 (Female)
  - 4PT-M JST XARR-04VF connector
  - 2PT-M 2-pole SXH-002T-P0.6 terminal (Male)
  - 2PT-F 2-pole SXH-002T-P0.6 terminal (Female)
  - R M4.3, Stocko RSB 7206 A4-1 Ring Terminal
  - M4.8 Male faston connector 0.8 mm thickness
  - S-S Directly solder with heat shrink sleeve

1. Due to the high wattage of the product, only the specified cordset must be used.
2. When replacing the **ELECTRO VALVE 27 & RINSE VALVE 29**, please be reminded to apply loctite at the joints for good sealing.
3. After the product is repaired, it should function properly & must meet the safety requirements & legal regulations as laid down & officially established at this moment.
4. Basic checks for the **STAND ELECTRONICS 37** as follows:
  - 4.1. Check for incoming AC voltage measured at L5 and N5 (220 - 240 V AC)
  - 4.2. Check for AC power supply to Iron unit between L1 and N1 (220 - 240 V AC)
  - 4.3. Check for output of 24 V DC and 5 V DC from **SMPS ELECTRONICS 58**.
5. Automatic calc-cleaning system.
  - 5.1. The calc clean process will automatically activate after 3.5 hrs of steaming. In terms of product usage time, it would depend on how often the consumer uses steam when he/she uses the product.
  - 5.2. It is possible for service center to manually activate Auto Calc Clean process before time is due. The steps involved are as follows:
    - Unplug cordset from mains socket.
    - Allow boiler to cool down.  
(Boiler temperature must be < 50 Deg C for auto calc clean to take place)
    - Remove **RINSE TANK ASSY 56**
    - Press & hold **BUTTON-SUCTION 16, TRIGGER 19** on iron handle while plugging into the mains socket.
    - Blue **AUTO CALC CLEAN** light starts flashing & the appliance beeps, indicating the auto calc cleaning process is in progress.
    - This process lasts approximately 3 minutes.
6. The **CARTRIDGE BLUE PACK ASSY 61 (GC018)** is **ONLY** for use in GC9940 / GC9950. It should **NOT** be used in GC9920.
7. For GC9920, please use **CARTRIDGE BROWN PACK ASSY (GC017) ONLY**. Its service code is 4239 021 64851.
8. **IMPORTANT** to note that the blue cartridge & the brown cartridge are **NOT** to be used interchangeably.

WIRE ASSY SIGNAL 71

FAN GASKET 68

FAN ASSY 69

- Remove bolts R1 - R4
- Disassemble Fan grille
- Disconnect WIRE ASSY SIGNAL 71
- Disassemble FAN GASKET 68
- Disassemble FAN ASSY 69

BOARD HOUSING ACTIVE 64

- Remove BOARD STICKER 67 (on Active Board)
- Remove screws S1 - S20
- Remove board plugs T1 - T3
- Disassemble BOARD HOUSING ACTIVE 64

Reassembly tip

Adjust board plug C1, C2, C3 clockwise & counter-clockwise to align screw holes between board frame & board housing before screwing.

Reassembly tip

Replace with new BOARD STICKER 67 after reassembling BOARD HOUSING ACTIVE 64.

PARTS LIST - IRONING BOARD

Pos	Service code	Description
63	4239 017 12171	Wire assy Board chassis CW
64	4239 021 49753	Board housing Active
65	4239 026 33183	Cover button Refresh
66	4239 021 49762	Board housing Passive
67	4239 026 25900	Board sticker
68	4239 015 56230	Fan gasket
69	4239 017 11040	Fan
70	4239 017 10109	Board cover
71	4239 017 76051	Wire assy Signal - Shrink wrap
72	4239 022 67471	Board cover and Felt

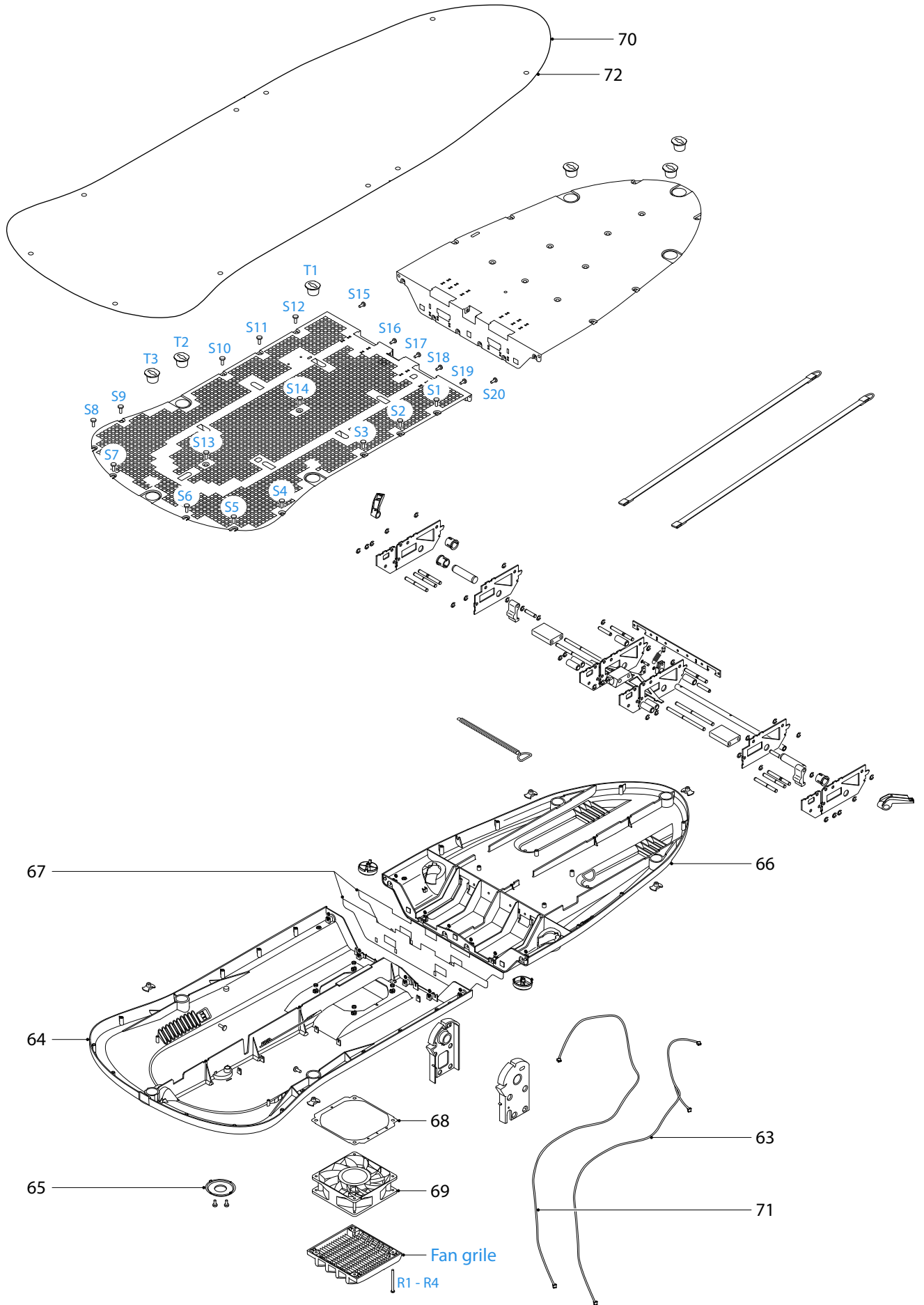

**MOVING COLUMN ASSY 15**

- Remove screws F1 - F4
- Disassemble BACK COVER TOP 53
- Remove screws K7 - K10
- Disassemble PANEL LEFT ASSY 50
- Disconnect 4-pole cable W4, Quick-connectors Earth on STAND ELECTRONICS 57

Undress the disconnected wires so that their ends are hanging freely from position Loc 1:

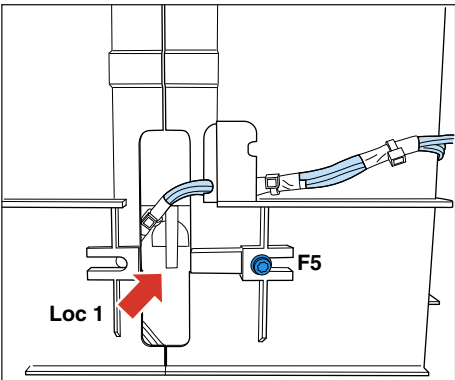
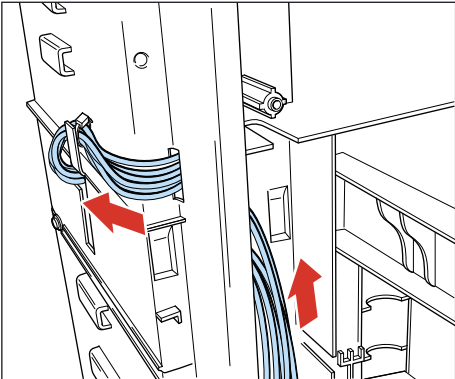

- Remove screw F5
- Press Handle lift left & Handle lift right
- Pull upwards IRONING BOARD-MOVING COLUMN assy, detaching completely from the Stand.
- Place IRONING BOARD-MOVING COLUMN upside down, lying flat on ironing board surface as follows:

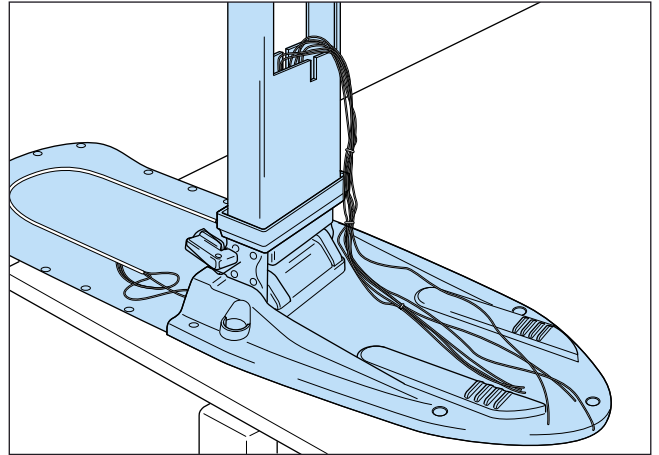

Unhook 2x straps from the springs as follows:

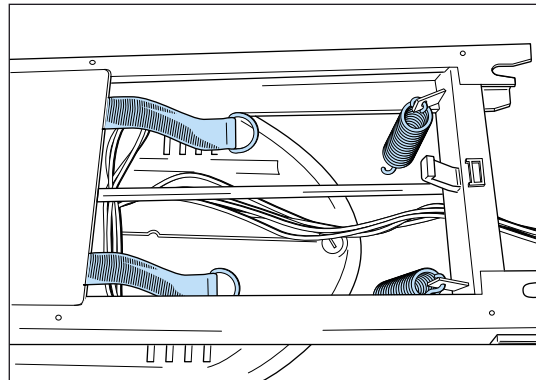
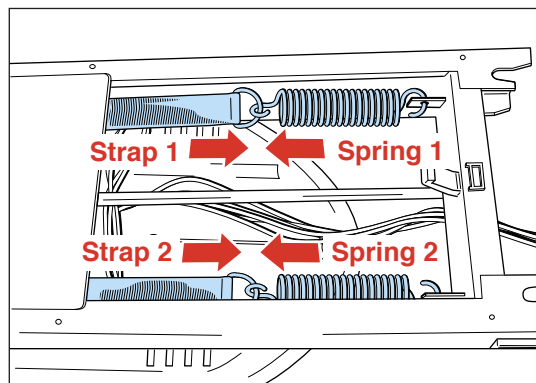

## DISASSEMBLY ADVICE - MOVING COLUMN

# GC9940

- Remove screws U1 - U4
- Disassemble Plate pivot flange left
- Disassemble Plate pivot flange right
- Disassemble Handle lift left
- Disassemble Handle lift right
- Remove screws V1 - V8
- Cut 3x cable ties to free the wires on MOVING COLUMN ASSY 62

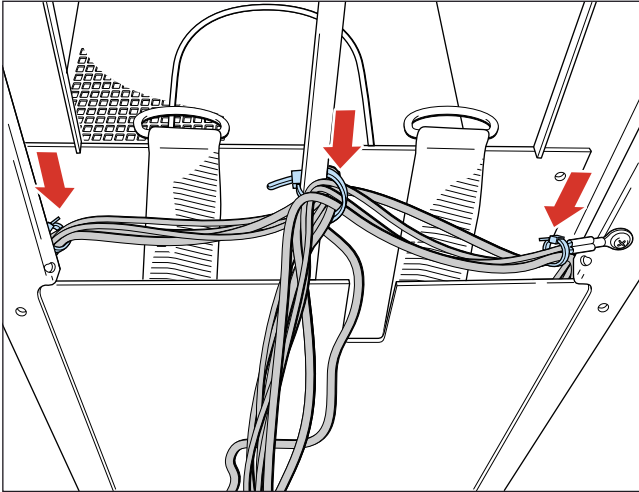

Disassemble MOVING COLUMN ASSY 62

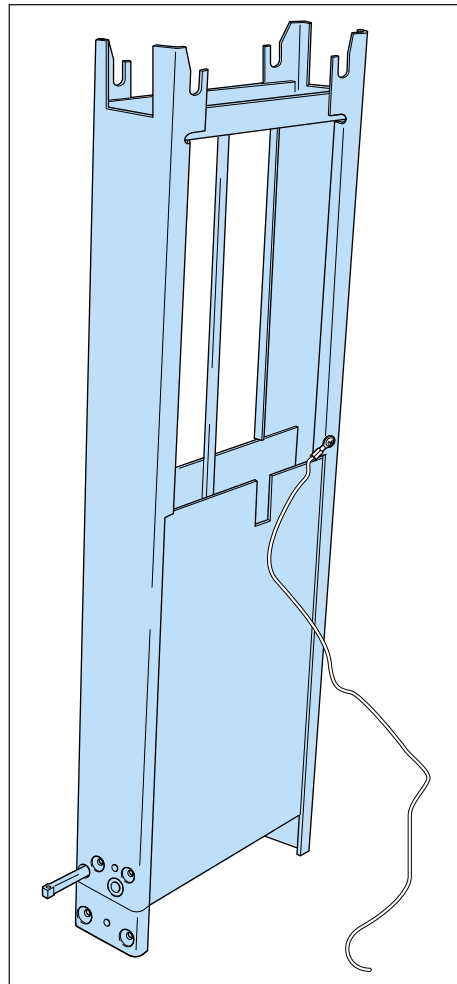
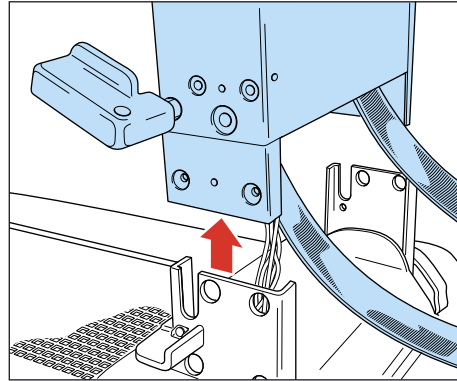

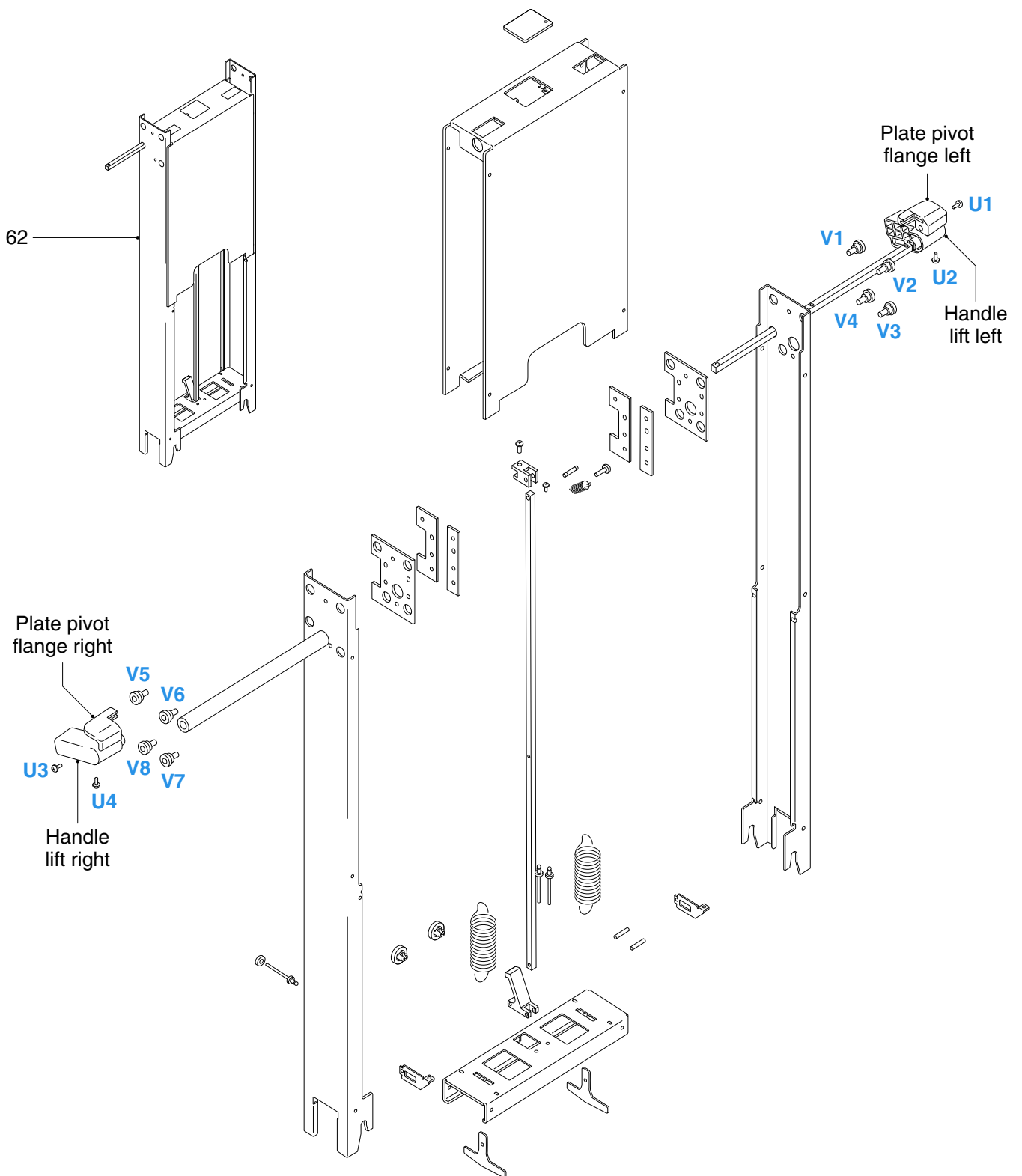

Pos	Service code	Description
62	4239 020 03051	Moving column assy