

Service
Service
Service



Philips Consumer Lifestyle

Service Manual

PRODUCT INFORMATION

Safety info

- This product meets the requirements regarding interference suppression on radio and TV.
- After the product has been repaired, it should function properly and has to meet the safety requirements as officially laid down at this moment.

TECHNICAL INFORMATION

- Voltage : 220 - 240 V
- Frequency : 50 - 60 Hz
- Power consumption : 1000 W
- Standby power : 0.5 W
- Contents jug : 1200 cc
- Colour setting HD7740 : Black / Metal
- Filter size : 1 x 4
- Dimensions (L x H x W) : 310 x 430 x 215 mm
- Temperature coffee after brewing : 80 °C
- SAP coding : HD7740

OPTIONAL (accessories)

- No specific issues

A. Heating element removal

1. Turn the appliance upside down and remove the bottom from the base by unscrewing the 4 screws **A** under the rubber foot.
2. Remove the heating element by unscrewing the 5 screws **B**.
3. Remove the tubes from the heating element and disconnect the wires.

B. PCB removal

1. Turn the appliance upside down and remove the bottom from the base by unscrewing the 4 screws **A** under the rubber foot.
2. Remove the 2 screws **C**.
3. Disconnect the wires.

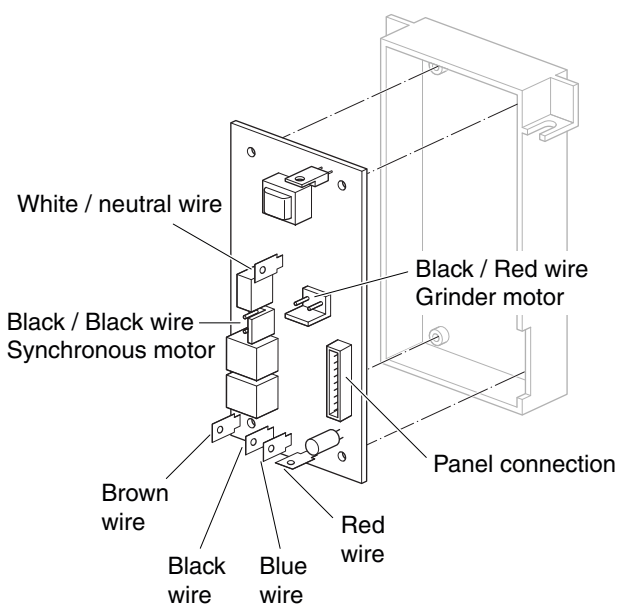

C. Grinder Motor removal

1. Unscrew the bean tray by unscrewing the 3 screws **D**.
2. Unscrew the 8 screws **E** on the top cover. Be aware of the 2 screws under the tank lid. They are protected by plastic caps, and can be very hard to remove. You can try blowing them out with a shot of compressed air, otherwise you may have to use a drill to get them out. New caps are available as 12nc: 4222 459 48871 (Pos 6.).
3. Remove the 7 screws **F** en 4 screws **G** from the grinder motor. (See picture with Pos 10 Grinder Motor)
4. Disconnect the Black / Red wire on the PCB. (See instructions **B**). Unfortunately there is a ferrite bead around the leads preventing easy removal, it may be necessary to cut out a small piece of the plastic bridge in the appliance to get it out.

5. During installation of the grinder motor be aware of the position of the Knob compared with the position of gearwheel 4. On gearwheel 4 you will see an arrow and when this arrow points to the marked line, the Indication on the knob has to point to number 5. This means the flat side of gearwheel 1 has to be on the side off the front panel.

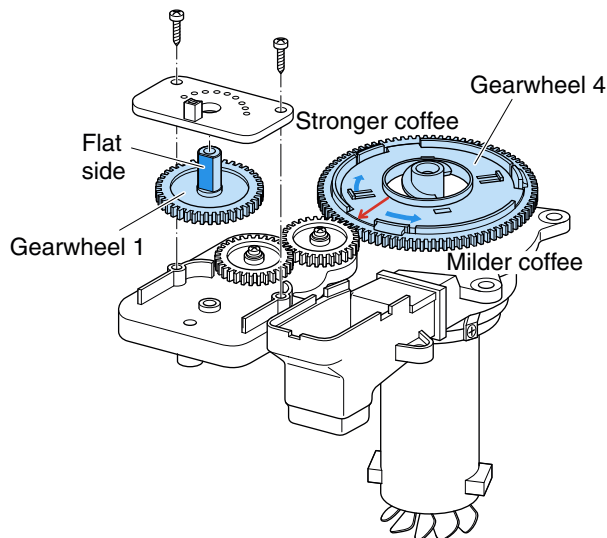

Remark;
How to set the motor grinder in a stronger or milder coffee position?

When in the maximum setting, the coffee is not strong or mild enough; the motor grinder can be changed in a stronger coffee position by turning the gearwheel 4 a couple of gear teeth to the left. The motor grinder can be changed in a milder coffee position by turning the gearwheel 4 a couple of gear teeth to the right.

D. Front panel removal

1. Remove the 2 screws **H**.
2. Disconnect the wire flat cable on the PCB. (See instructions **B**).
Be aware to use the rails when refitting the front panel with the base, and be aware to guide the wires along the motor correctly.

E. Filter holder Housing removal

1. Turn the appliance upside down and remove the 2 screws **I**. (See picture pos 15 filter holder housing)
2. Remove the axle, and remove the filter holder housing.

De-scaling

If the water system is nearly or less clogged by scale then operate the coffeemaker a few times with vinegar or with a 10-15% solution of either vinegar-acid, citric acid or tartar acid, into cold tap water.

Do not use other de-scaling agents as these may harm the appliance.

If this procedure does not restore the function, then switch off the coffeemaker when the acid has passed through during approximately 3 min. Keep the appliance in this condition overnight and continue/repeat the cleaning operation.

After the de-scaling procedure, operate the coffeemaker twice with tap water in order to rinse away any residual substances.

ELECTRICAL DIAGRAM

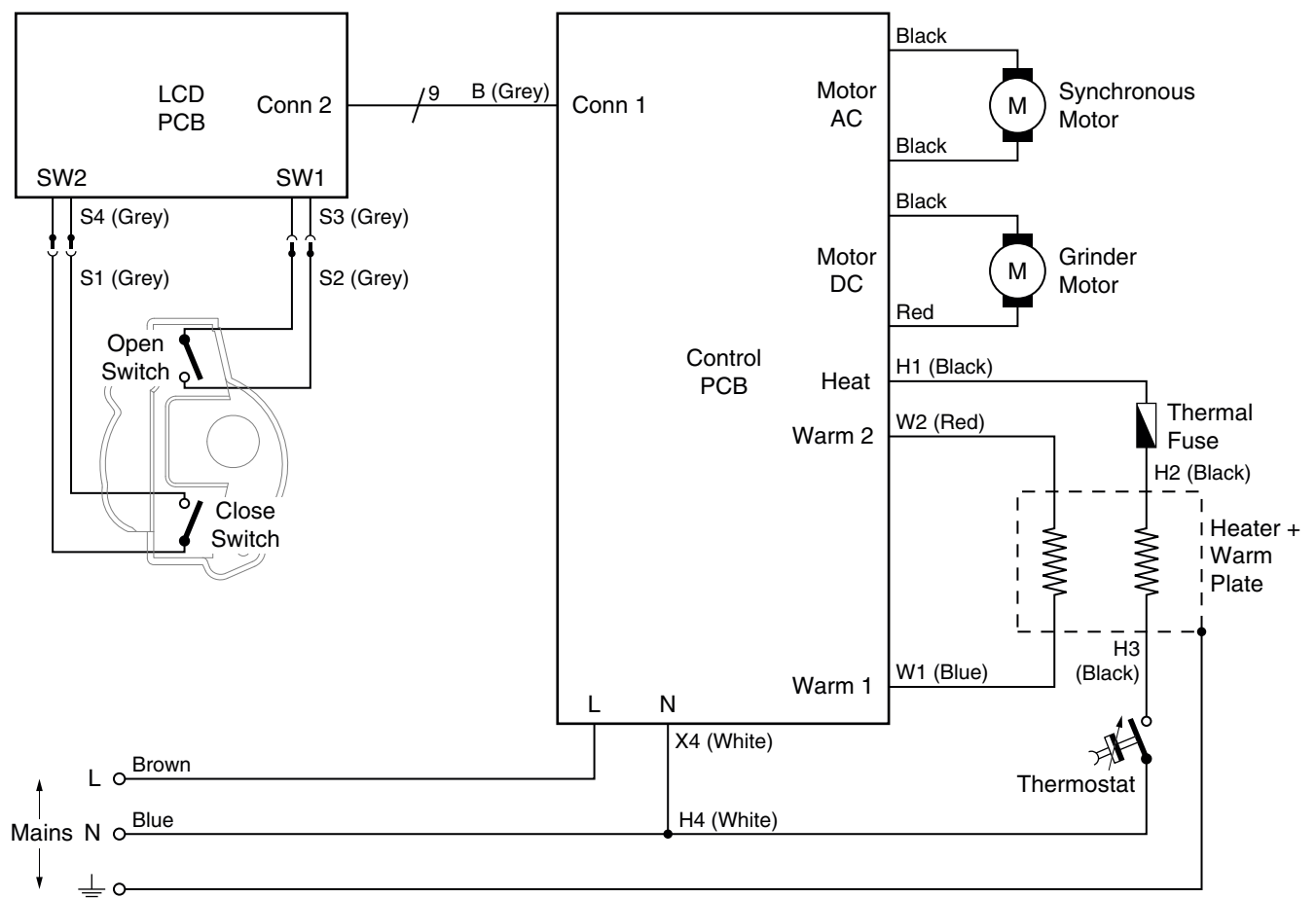

Pos	Service code	Description	
1	4222 459 48891	Heating element	220 - 240 V
2	4222 459 48901	PCB	220 - 240 V
3	4222 459 48941	Bean tray lid	
4	4222 459 49001	Bean tray assy	
5	4222 459 48931	Tank lid	
6	4222 459 48871	Screw cap	
7	4222 459 48961	Cleaning window	
8	4222 459 48971	Sealing ring	
9	4222 459 51781	Knob	
10	4222 459 48851	Grinder motor	220 - 240 V
11	4222 459 48861	Panel	220 - 240 V
12	4222 459 51761	Permanent filter	
13	4222 459 48911	Filter holder + dripstop	
14	4222 459 48881	Hinge	
15	4222 459 48921	Filter holder housing	(Eu)
17	9965 100 52541	Jug assy 12 cups	Metal / Black
18	4222 459 48951	Brush	
19	4222 247 35400	Spoon	
20	4222 459 53231	Hose incl. checkvalve and spring	
21	4222 459 54591	Top cover	
22	4222 459 53651	Locker assy	
24	9965 100 54134	Synchro motor assy	
	4222 459 56181	Liquid sealant (tube 45g)	

EXPLODED VIEW

HD7740

