

Service  
Service  
Service



Philips Consumer Lifestyle

# Service Manual

## PRODUCT INFORMATION

### Safety

- This product meets the requirements regarding interference suppression on radio and TV.
- After the product has been repaired, it should function properly and has to meet the safety requirements as officially laid down at this moment.

## TECHNICAL INFORMATION

- Voltage : 220-240V
- Frequency : 50 Hz
- Power consumption : 1000W
- Color setting : Black / Metal
- Dimensions
  - Appliance H x W x D : 440 x 210 x 310 mm
  - F-Box L x W x H : 320 x 280 x 505 mm
- Cord length : 0,8 m
- Filter size : 1x4
- Contents
  - Jug (max.) : 1320 mL
  - Water container (min.) : 264 mL (2 cups)
  - Water container (max.) : 1320 mL (10 cups)
  - Avg. water loss during brew process : 10%
- Materials
  - Appliance : PP
  - Metal wrap : Stainless steel
  - Jug : Glass
  - Hoses : Silicon
- Brew time (max.) : 10 min
- Temperature (full jug) : > 80 °C
- Keep warm time : 120 minutes  
: 30 min per WK1501  
for EU countries only
- Auto Shut-off time : 30 mins

**De-scaling**

When the appliance indicates it needs to be descaled, operate the coffeemaker a few times with vinegar or with a 10-15% solution of either vinegar (acetic acid), citric acid or tartar acid, into cold tap water.

Use a paper filter to catch any particles coming out.

Do not use other de-scaling agents as these may harm the appliance.

If this procedure does not restore the function, then switch off the coffeemaker when the acid is passing through. Keep the appliance in this condition overnight and continue/ repeat the cleaning operation.

After the de-scaling procedure, operate the coffeemaker twice with tap water in order to rinse any residual substances.

**Schematics**

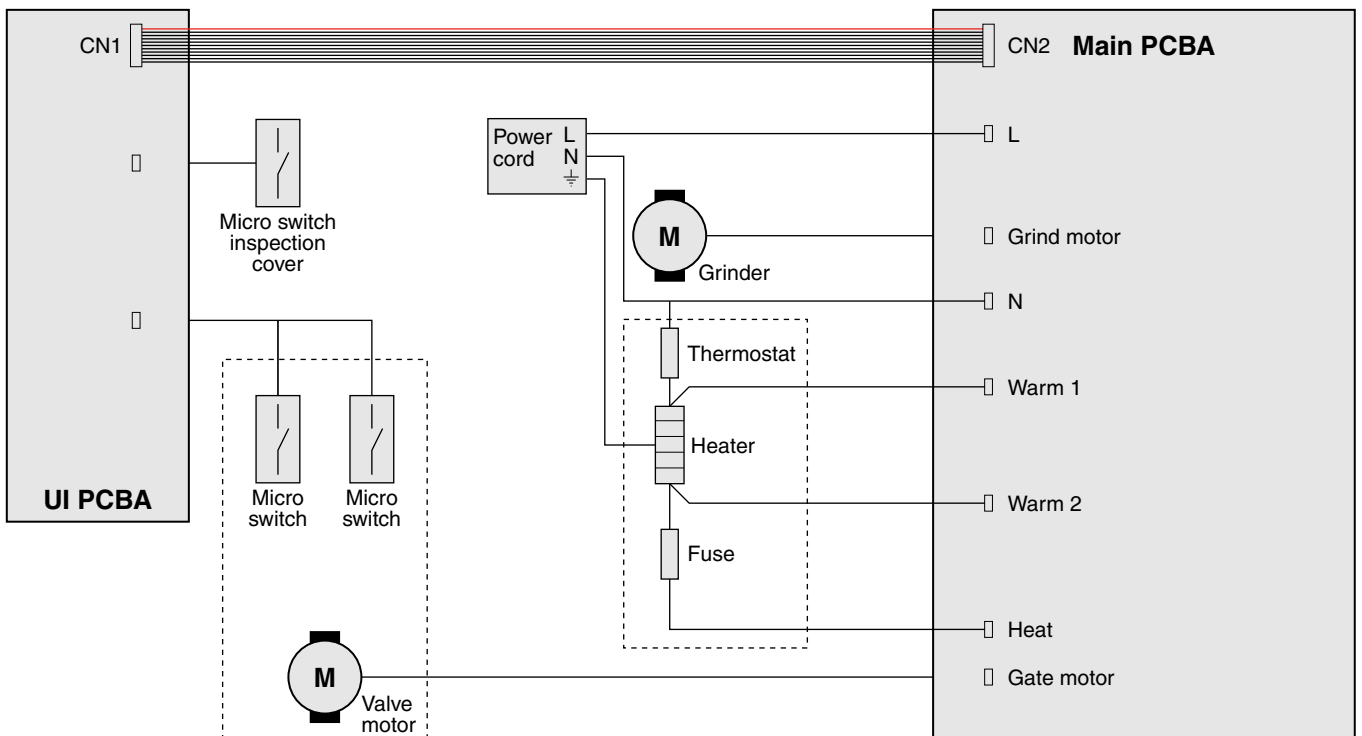

**Self-Check mode**

The appliance is equipped with a self-check mode, this enables you to quickly check the function of the main components of the unit.

	Keep the On/Off button pressed while plugging the mains cord into the socket.	Left side display	Right side display
Press <b>any other</b> button	Hardware version	CH	201
Press <b>any other</b> button	Software version	CH	0004
Press <b>any other</b> button	Heating element enabled	CH	1
Press <b>any other</b> button	Heating element disabled	CH	2
Press <b>any other</b> button	Grinder motor enabled	CH	3
Press <b>any other</b> button	Grinder motor disabled + 6 Beeps	CH	4
Press <b>any other</b> button	Microcontroller check	CH	5 = ok E1 = Nok
Press <b>any other</b> button	Zero-cross detection	CH	6 = ok E2 = Nok
Press <b>any other</b> button	Valve micro switches	CH CH CH	CLO = valve is closed ---- = valve is working OPE = valve is open
Press <b>any other</b> button	Inspection window micro switch	L- = Closed H- = Open	8 8
Press <b>any other</b> button	Thermostat	CH CH	1111 = Thermostat closed 0000 = Thermostat open
Press <b>any other</b> button	Rotary knob	2	9
Press <b>any other</b> button	Rotary knob rotate clockwise	Increasing	9
Press <b>any other</b> button	Rotary knob rotate anti-clockwise	Decreasing	9
Press <b>any other</b> button	LED check	All digits on	All digits on
Press <b>any other</b> button	LED check	All digits off	All digits off
Press <b>On/Off</b> button	Stand-by		

Repair of this appliance should be carried out on part and or assembly level, most repairs can be allocated to a couple of main components:

- **Bean container and duo-bean mechanics**

Disassembly instructions until Step 1.

- **User interface assy**

Disassembly instructions until Step 4.

When in the UI panel itself has been disassembled, please make sure the wire and flat cable seal is properly installed.

Upon reinstallation of the complete panel, please make sure the seal underneath the UI panel is put back.

- **Main PCBA**

Disassembly instructions until Step 4.

When only the PCBA needs replacement, skip steps 1 - 3. Upon reinstallation of the PCBA, please make sure the PCBA holder slides back into its guiding recesses. Please note the position of the Grinder (DC-motor), and Synchro-motor (AC-motor) leads, when reversed the appliance will not start up.

- **Grinder**

Disassembly instructions until Step 6, skip step 3 and 5.

It is not advisable to disassemble the grinder, as this will disrupt the grinders' calibration. In production special tools are used to adjust the grind-fineness to the optimal level.

- **Synchro motor + valve and seal**

Disassembly instructions until Step 6, skip step 3 and 5.

When the valve and or seal have been removed, please make sure that the seal does not get damaged, and that the seal gets reinstalled correctly. The seal is critical to seal the grinder from steam coming from the coffee filter.

- **Heater, bottom water supply**

Disassembly instructions Step 4 and 5.

It is not advisable to disassemble the heater from the keep-warm plate. Heat-conductive paste should be applied to ensure optimal heat transfer from the element to the plate, jug and coffee.

- **Top water supply**

Disassembly instructions Step 1 and 2.

The Silicon hose between the elbow joint and the showerhead does not need to be removed to uninstall this component, when the hose does need replacement, make sure the hose clamps are put back properly, this is to prevent leakage.

When the showerhead has been removed it should be cleaned from any residual liquid gasket and new liquid gasket (supplied in tubes of 45 g.) should be applied to ensure a proper seal.

- **Complete Base, incl. metal wrap**

Disassembly instructions Step 4 and 5.

The main PCBA and Heater assy need to be taken out completely, the base is screwed to the top by means of 6 screws.

Remove all removable and detachable items like the Bean container lid, jug, filter holder and brush. The filter door can be removed for convenience by undoing both latches on the top and bottom side of the hinge.

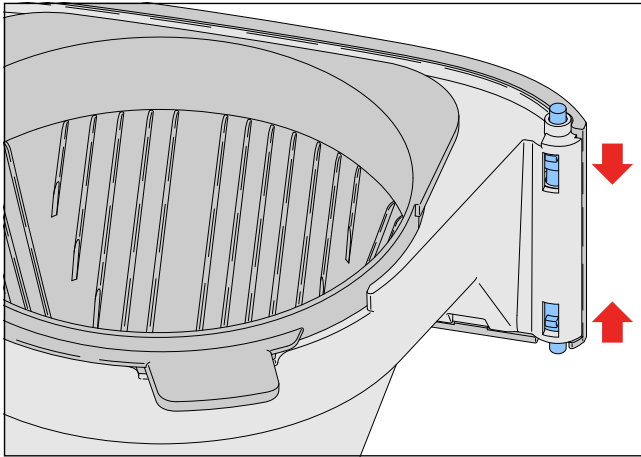

**Step 1: Bean container removal**

To remove the complete bean container, including Duo-Bean feature, remove the 4 screws (C) inside the bean container.

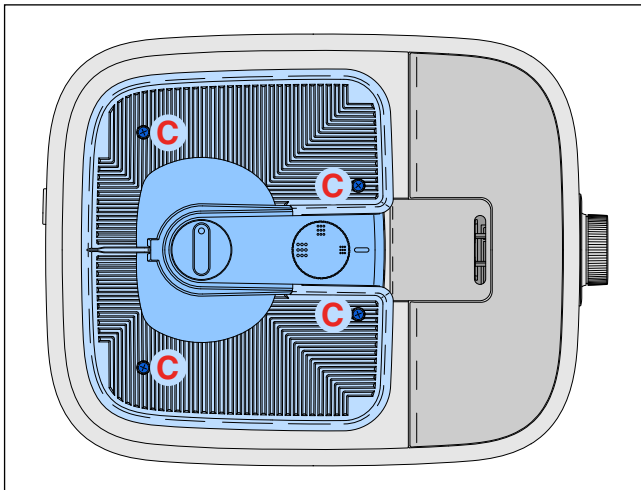

**Step 2: Top cover removal**

The top cover can be opened by removing the four screws (F) located underneath the Bean container and the four screws (G) accessible from the underside of the UI panel.

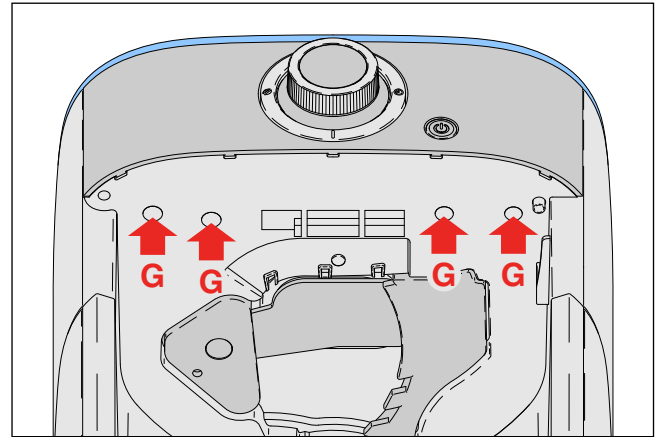
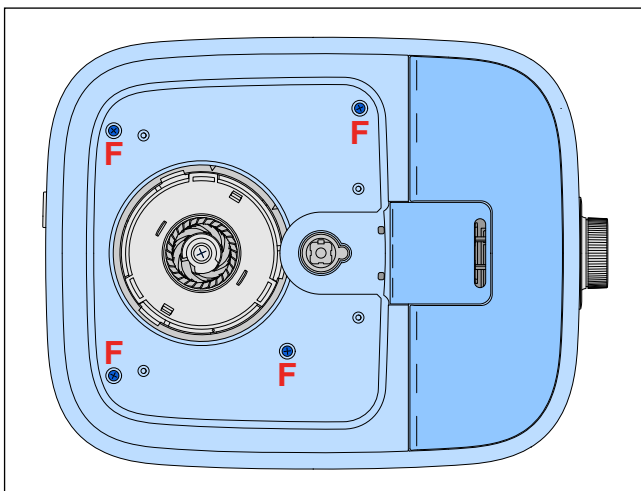

Please note the cable connecting to the Inspection window detection switch. The Water Level Indicator (WLI) cannot be removed without damaging the Top cover. When the top cover needs to be replaced the WLI can be reused, when the WLI needs to be replaced a new top cover needs to be ordered as well.

**Step 3: UI panel removal**

To be able to remove the UI panel, you need to disconnect the leads to the Synchro motor, and the flatcable to the main PCBA. The UI panel is held in place by two screws accessible from the top side of the appliance, and 5 clicks accessible from the bottom side of the UI panel. Unscrew both screws (J).

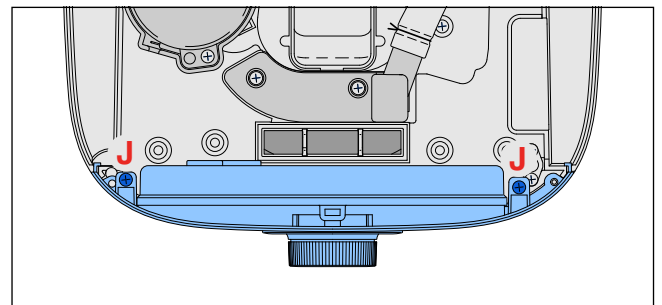

Undo the snaps by tracing the curve of the UI panel with a flat-head screwdriver, while pulling the UI panel upwards.

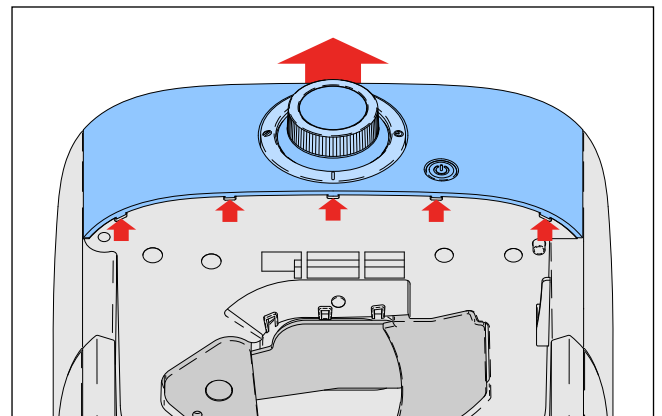

The UI panel can be disassembled, the rotary knob can simply be pulled off, the rotary encoder is secured by a single nut, remove the nut. The PCBA cover is held in place by six screws (L), once unscrewed the PCBA can be taken out. Please mind the rubber seal, preventing steam from reaching the UI PCBA.

**Step 4: Bottom cover & Main PCBA**

To be able to replace the components in the top side of the appliance (like the Grinder and Synchro motor), their leads need to be disconnected from the main PCBA. To reach the main PCBA, remove the six screws (P) in the bottom cover, four of them are located underneath the rubber feet.

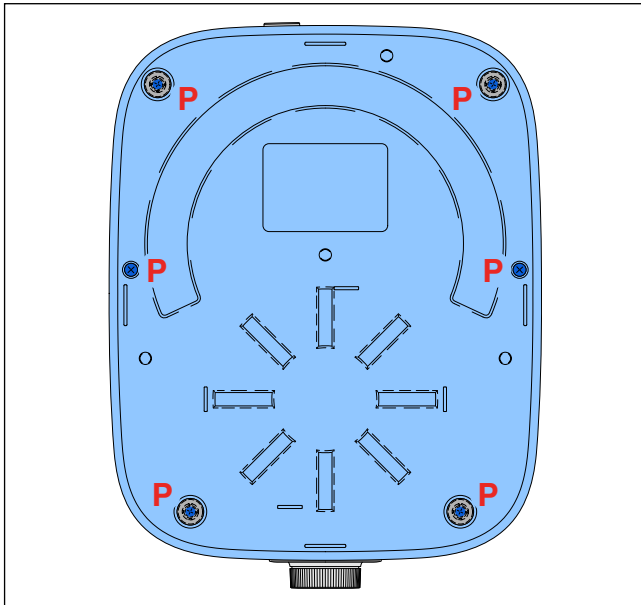

The PCBA is in the plastic box indicated in blue, some leads need to be released before you can take out the PCBA completely.

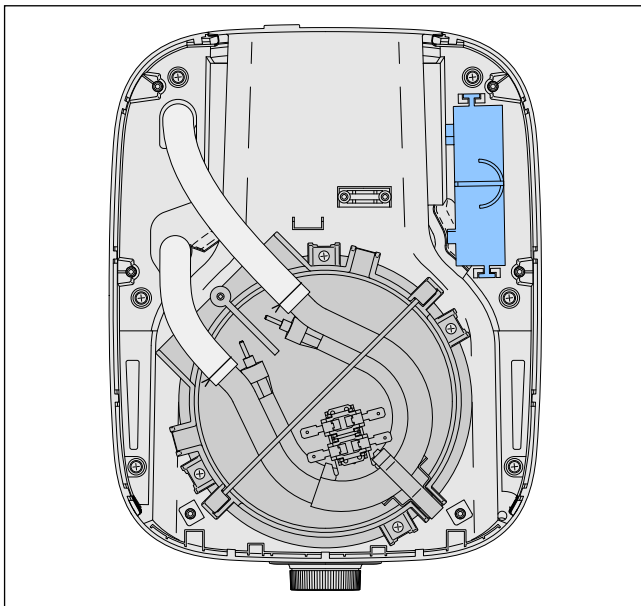

**Step 5: Heater assy**

To replace the heater assy disconnect the leads from the main PCBA and the Silicon hoses from the pinions on the heater. Only the four screws (O) indicated below hold the heater assy (incl. keep warm plate) in place. The top silicon hose is the cold water intake, the bottom silicon hose is the hot water output. It connects to the top water supply.

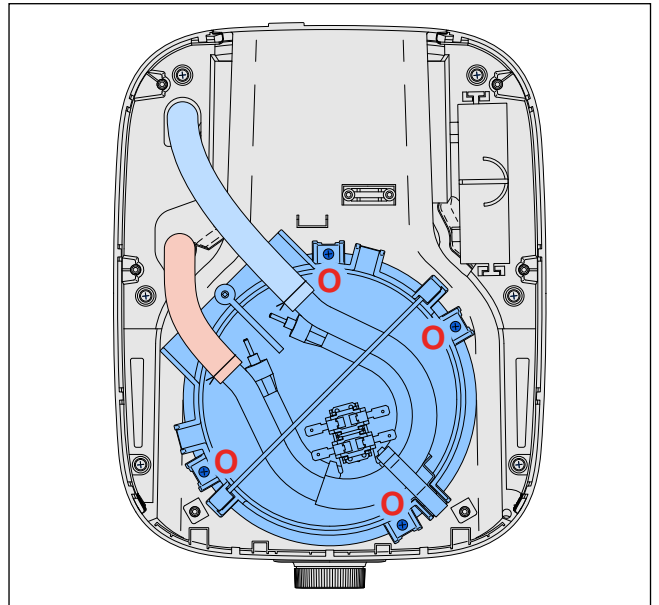

**Step 6: Grinder, Synchro motor and Water supply**

To remove the Grinder, disconnect its leads from the main PCBA and undo screws (U). To remove the Synchro motor remove its leads from the main PCBA and undo screws (V). The top water supply, consisting of the shower head, silicon hose, elbow and riser pipe, can be removed by undoing screws (S), only when the Silicon hose needs replacement the clamps need to be undone.

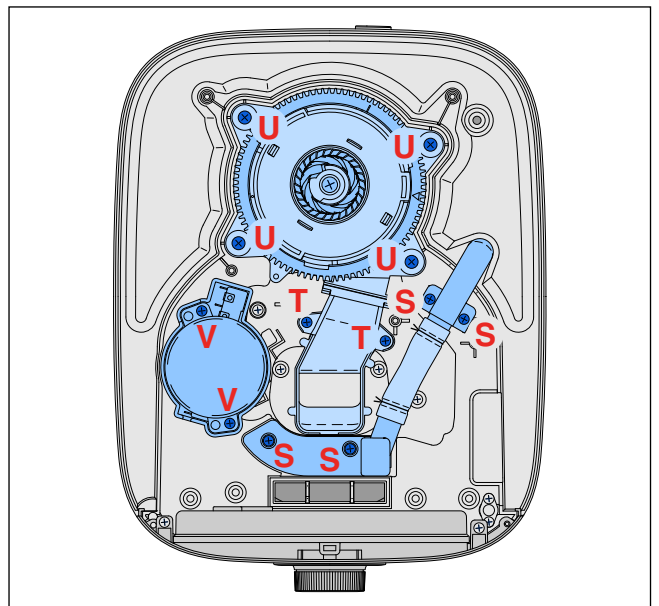

## REASSEMBLY INSTRUCTIONS

# HD7766/00/D

Basically the reassembly needs to take place tracing the steps needed to disassemble the appliance. There are some critical attention points:

All the gaskets in the appliance must be reinstalled properly

### Gasket on top of the grinder

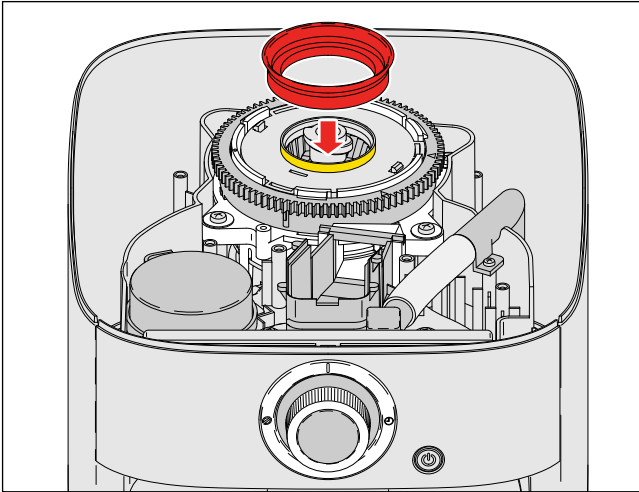

### Gasket for the wires entering the UI panel

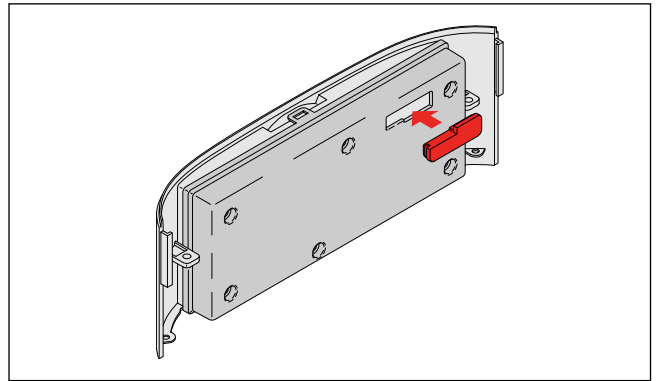

### Gasket for the valve / Synchro motor

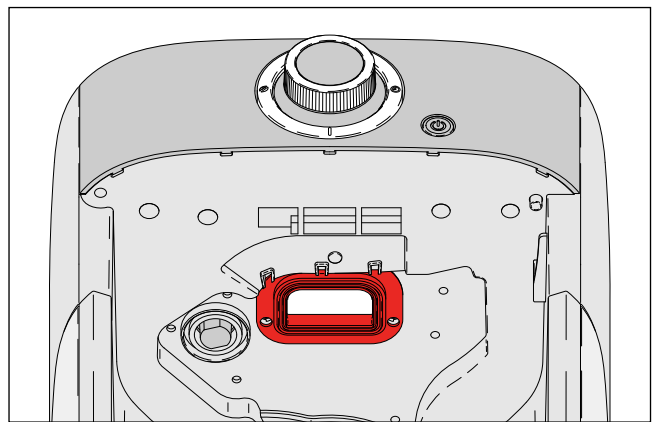

### Gasket under the UI panel

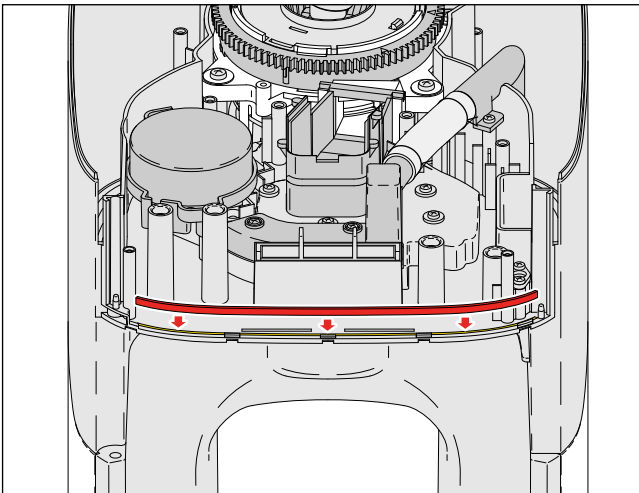

### Gasket for the steam vent

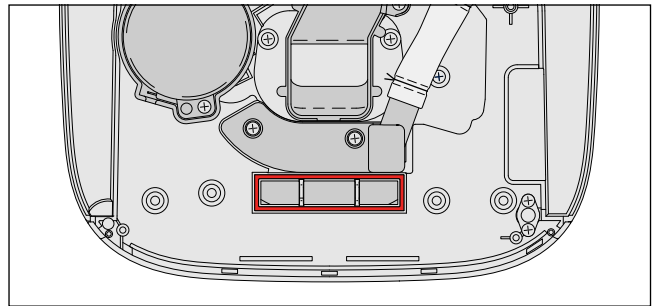

### Gasket of the UI panel

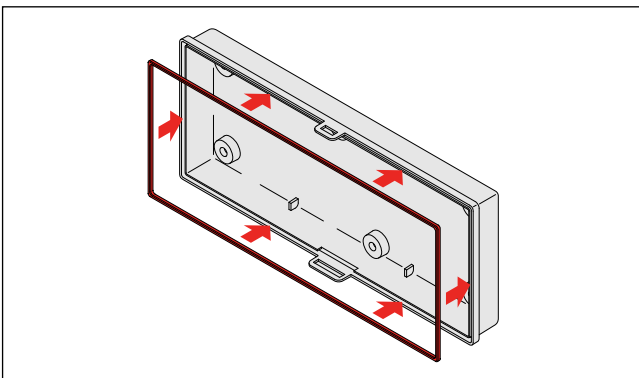

### Gasket for the steam base

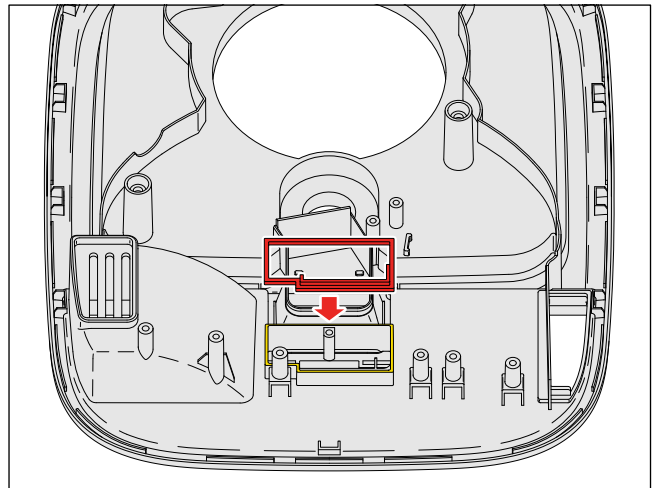

## REASSEMBLY INSTRUCTIONS

# HD7766/00/D

All the liquid seals, when broken, need to be replaced. This includes cleaning the mating surfaces and applying sufficient new liquid sealing.

### Gasket of the Shower head

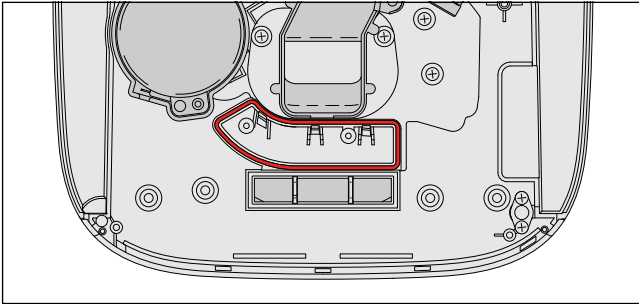

When the UI panel or Synchro motor has been removed, special attention is needed to the proper wire routing from top to bottom. All wires must pass through the slots as indicated in red in the cross section below. They may not be passed through the opening for the Grinder.

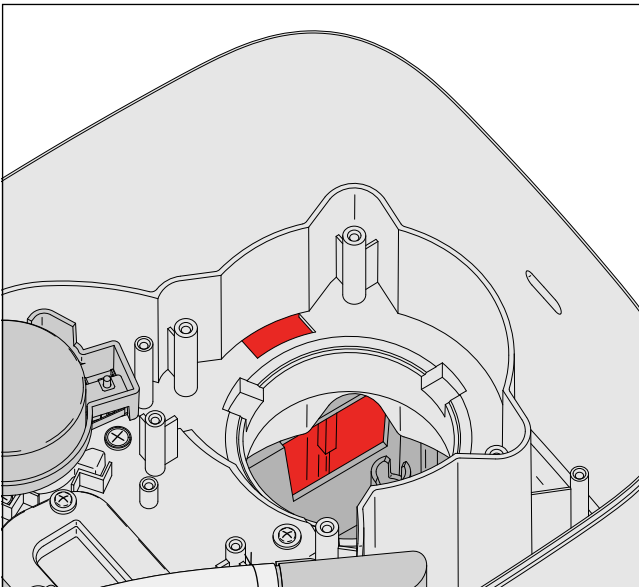

### Bottom Cover

Upon reinstallation of the bottom cover, please mind that the notch on the PCBA holder fits into the recess of the bottom cover.

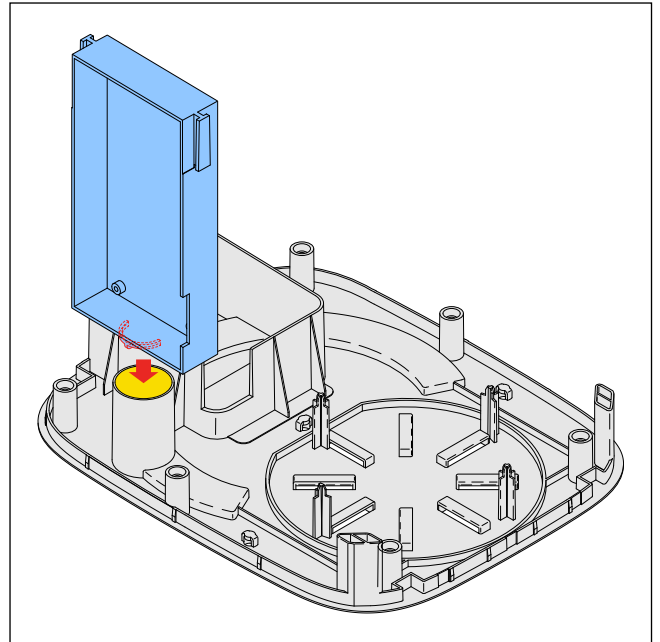



Pos	Service code	Description
1		Door assembly
110	9965 100 64722	Filterholder assy
120	9965 100 64767	Filterdoor assy
2	9965 100 73714	Jug assy Aroma swirl
3	4222 459 48951	Brush
4	9965 100 64753	Bean container cover
5		Bean container assy
510	9965 100 64723	Ground fineness knob
511	9965 100 64726	Knob cover
512	9965 100 64774	Selector knob
513	9965 100 64756	Top localizer
514	9965 100 64745	Bottom localizer
515	9965 100 64741	Spring
516	9965 100 64735	Shield
517	9965 100 64718	Bean tray
518	9965 100 64776	Selector axle
6	9965 100 64766	Grinder seal
7	9965 100 64752	Top cover assembly
710	9965 100 65253	Water lid
711	9965 100 65252	Inspection window
712	9965 100 65255	Seal
713	9965 100 64742	Water level indicator
<b>715</b>	<b>9965 100 75345</b>	<b>Locker assembly</b>
720	9965 100 65254	Micro switch assy
8	9965 100 71811	User interface assembly ASO
810	9965 100 64725	Cable seal
811	9965 100 64721	Back cover
812	9965 100 71809	UI PCBA ASO
813	9965 100 64765	Seal
814	9965 100 64775	Front cover
815	9965 100 64762	Rubber ring
816	9965 100 64727	Pin
817	9965 100 64769	Selector ring
818	9965 100 64737	Deco ring
819	9965 100 64744	Knob + cover
820	9965 100 64731	On/Off button

Pos	Service code	Description
9	9965 100 64754	Steam vent seal
10	9965 100 64759	UI assy seal
12	9965 100 71806	PCB assembly in box
13	9965 100 64749	Heater element assembly
1315	9965 100 64719	Thermostat / fuse
14		Base assembly
1411	9965 100 64729	Base plate
1412	9965 100 64736	Foot
15	9965 100 64746	Grinder coarseness adjustor assy
16		Water supply assembly
1610	9965 100 64733	Elbow
1611	9965 100 73719	Spout hose
1612	9965 100 73718	Spout /D
1614	9965 100 64748	Riser pipe
17		Valve motor assembly
1710	9965 100 64761	Valve motor
1711	9965 100 64732	Bracket + switches
1712	9965 100 64757	Switch actuator
18	9965 100 64777	Filter locker kit
19	9965 100 73715	Grinder assy
20	9965 100 73716	Top housing /D
21	9965 100 73759	Valve seal kit
22	9965 100 64768	Valve kit
2310	9965 100 64773	Bottom housing
24	9965 100 71915	Clamp
25	9965 100 71917	Hose Tank to Heater incl. valve
26	9965 100 71844	Shower head seal
27	9965 100 71916	Hose Heater to Shower head
28	9965 100 72826	Power cord (EU)

