

Service
Service
Service



Philips Consumer Lifestyle

Service Manual

PRODUCT INFORMATION

- This product meets the requirements regarding interference suppression on radio and TV.
- After the product has been repaired, it should function properly and has to meet the safety requirements as officially laid down at this moment.

TECHNICAL INFORMATION

- Voltage : 230 V
- Frequency : 50 Hz
- Power consumption : 1450 W
- Standby power consumption : 0.002 kWh
- Contents reservoir : 755 cc
- Colour setting : Blueberry purple / Black

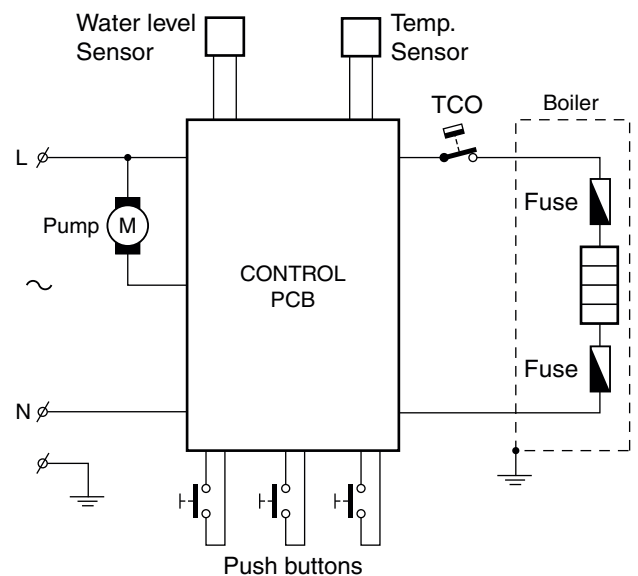

Disassembly information

To remove the brew chamber lid cover handle as follows:

- Place the screwdriver on the positions (see picture 1) and lift the cover over the snap locks on both positions.

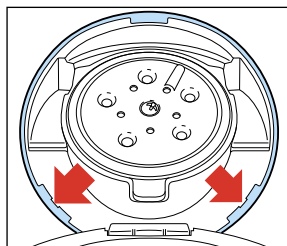

picture 1

- The cover lid can now be lifted up a little and to remove the complete cover including lever and push rod squeeze strongly with two fingers both legs of the push rod (see picture 2) to each other, so that the two pins will get out of the hinge position on the brew chamber.

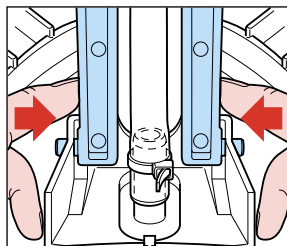

picture 2

- To remove lever from lid cover, take a screwdriver and bend carefully the two lips/ribs in the lid cover outwards and push the lever with force out of the hinge.
- Reassemble follow steps backwards, without using a screwdriver.

To remove the back cover handle as follows:

- Remove valve outlet.
- Start at the upper side of the back cover and stick a screwdriver into the 2 snap locks positions and gently pull the back cover from the appliance so that a little chink between back cover and brew chamber becomes visible.
- Put the screwdriver in to the 4 rectangular holes (snap locks) at the back and gently pull the screwdriver such away that the lips of the snap locks are bent outwards.
- If all clicks positions are loose, it is possible to remove the back cover.
- Reassemble follow steps backwards.

Removing Brew chamber head handle as follows:

- Disassemble back cover!
- Place the appliance such a way that you are looking at the boiler.
- First remove the boiler from the snap lock position of the brew chamber.
- To remove the brew chamber, use your both thumbs (see picture 3) and push strongly with a little distortion (rotation) until the brew chamber comes loose.

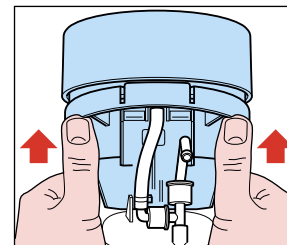

picture 3

- Reassemble follow above steps backwards.

To reach the components placed on the base handle as follows:

- First remove back cover, brew chamber and 3-way valve.
- Remove both Torx T15 screws see exploded view in the near of position A.
- Bend the 2 click snap locks with a screwdriver (see base), and the housing can now be removed.
- To remove the rest of the housing unlock the last 4 snap locks at the base and gently pull of the front cover.
- To reassemble follow above steps backwards.

OPTIONAL (accessories)

- XL watertank (10 Cups)
Commercial type number HD7982
Service code : 4222 259 20100

Descaling

Regular descaling will prolong the life of your appliance and will guarantee optimal brewing results for a long time.

- Follow the steps in the section headed “Preparing the appliance for use” see DFU (Direction for Use manual)
- Instead of only water use a mix of water and Lemon sour.
- For the best result leave the mix of water and Lemon sour for about 30 minutes in the appliance, before you start with flushing the appliance.
- To get the best results repeat above-mentioned step once or twice.
- When finished, flush the appliance twice by repeating the above-mentioned steps only use water instead.

Volume adjustment

The new PCB circuit board makes it possible to adjust the volume output by means of pushing the one-cup and two-cup user controls.

How to adjust the volume output:

1. Be sure the boiler is filled properly, other wise perform fill procedure see DFU for instructions.
2. Switch appliance on and wait until the unit is ready to brew.
3. Be sure a **pod holder** is placed, but **without** a Coffee POD. (Only adjusting with **plain** water)
4. Place a cup on the drip tray cover and push the one-cup button.
5. When the appliance has finished it is stabilized to perform the volume adjustment.
6. Empty the cup and push again for one cup setting, measure the volume output with a graduated beaker. In the table you can find the requirements for the minimum / maximum volume output cc/mL values depending from the country version:

One-cup setting, Including Pod holder, water spec. (Without Coffee pod)		
	Min. water cc/mL	Max. water cc/mL
France version	104	120
General version	127	143

7. Unplug the appliance from the mains.
8. Press the 1- and 2 cup button simultaneously and plug the mains on.
9. When above step succeeded the LED will turn on continuously.
10. Depending if the volume has to de- or increase you have to push the 1- or 2 cup button.
Every time you push the 1- or 2 cup button the LED will turn off for 0.5 second (feedback to user) and the pump time will be shorten or lengthen for 0.5 seconds depending which button was pushed.
Pushing 1 cup button pump, time will be **shorten** with 0.5 sec is approximately - 3.5 cc/mL (less coffee)
Pushing 2 cup button pump, time will be **lengthen** with 0.5 sec is approximately + 3.5 cc/mL (more coffee)

When the volume has to increase with 10 cc for example, push the **2 cup** button 3 times.

The new value will be stored when you switch the appliance off by pushing the main switch. (LED will turn off)

11. Turn appliance on again and brew one cup, measure the volume. In case the volume is not within specification repeat steps 6 - 11.
12. End.

Automatic filling procedure:

The Senseo PCB contains an automatic filling procedure software routine. This fill routine is only meant for **back-up**. Normally the consumer has to follow the guidelines stated in the DFU.

The filling procedure functions as follows:

The consumer has to fill the water container and has to plug the appliance on the mains.

When the Senseo main switch has been pushed the main switch LED will light continuously. This is only the case when the Senseo has not finished the filling procedure completely! (**First use**)

When the consumer pushes the one or two-cup button, the Senseo will start automatically the pump to fill the boiler. When the boiler is filled the pump stops pumping. (Pump time approximately 20 seconds)

When the filling procedure has been successful the software will clear a **Boiler_empty_flag** in the Eeprom.

By means of this **Boiler_empty_flag** the system knows the boiler is filled or not!

When the Senseo is switched off or disconnected from the mains, the value of the **Boiler_empty_flag** is stored in the Eeprom chip.

Restoring the Boiler_empty_flag to production default:

Some times it is needed that the boiler of the Senseo have to be emptied.

This for instance in wintertime were the possibility exists that the boiler becomes frozen during transport e.g.

For those occasions it is handy to restore the **Boiler_empty_flag** again to production default in the Eeprom.

Bringing the Senseo back into production status, has the benefit the flush routine will be activated automatically when installed by the consumer, see topic **Automatic filling procedure**.

To SET the **Boiler_empty_flag** can be done by:

Keep the 1-cup button pressed while plugging in the power cord of the appliance.

To check if the **Boiler_empty_flag** is really set, you should reconnect the power cord a second time to the net (do not push any buttons).

The LED should blink very fast for 0.5 seconds at the moment the power cord was connected to the net.

Pos	Service code	Description	Remark
1	4222 259 60381	Brew chamber assy	Blueberry purple
2	4222 259 38960	Pad holder assy 1-cup	Dark purple
3	4222 259 39022	Pad holder assy 2-cup	Dark purple
4	4222 247 35760	Foam chamber cover	Dark purple
5	4222 247 39540	Foam chamber	Black
6	4222 247 68701	Drip tray cover	Blueberry purple
7	4222 247 35790	Drip tray	
8	4222 259 49862	Front cover printed	Blueberry purple
9	4222 247 65442	Housing	Blueberry purple
10	4222 259 49842	Brew chamber lid printed	Blueberry purple
11	4222 247 38330	Lever	Dark purple
12	4222 247 35820	Pushrod	
13	4222 240 06400	Slider spring	
14	4222 247 35835	Slider	
15	4222 247 06810	Brew chamber seal	
16	4222 259 06890	Distributor assy	
17	4222 259 59541	3-way valve	
18	4222 259 52091	Boiler assy	V7.0 - 230 V
19	4222 247 61940	TCO cap	
20	4222 247 43690	Boiler pin cap	
21	4222 247 61971	Suspension bracket	
22	4222 247 06511	Pressure hose	
23	4222 259 52711	PCB assy ¹	
24	4222 247 39902	Button frame	Silver
25	4222 247 39941	On/off button cover	Silver
26	4222 247 39913	On/off button light guide	
27	4222 247 50504	Base plate	Black
28	4222 247 05130	O-ring	(NTC)
29	4222 259 39372	NTC assy	
30	4222 247 39963	Sensor housing	
31	4222 259 52201	Water container	Translucent dark purple
32	4222 247 40982	Valve outlet	Black
33	4222 259 36994	Back cover assy	Black
34	4222 259 37244	Pump	230 V/ 50 Hz
35	4222 247 05191	Pump damper	
36	4213 247 05256	Foot	
100	4222 244 50680	Ty-wrap	

¹⁾ When you replace the PCB the coffee volume has to be re-set to your country specific setting. Please carry out the Volume Adjustment Procedure to align the volume to your local specification (see table).

EXPLODED VIEW

HD7810/46

