

Service  
Service  
Service



Philips Consumer Lifestyle

# Service Manual

## PRODUCT INFORMATION

- This product meets the requirements regarding interference suppression on radio and TV.
- After the product has been repaired, it should function properly and has to meet the safety requirements as officially laid down at this moment.

## TECHNICAL INFORMATION

- Voltage : 220 - 240 V
- Frequency : 50 - 60 Hz
- Power consumption : 1450 W
- Standby power : <1 W
- Contents reservoir : 1200 cc
- Colour setting : White / Cashmere grey

## OPTIONAL (accessories)

- No specific issues

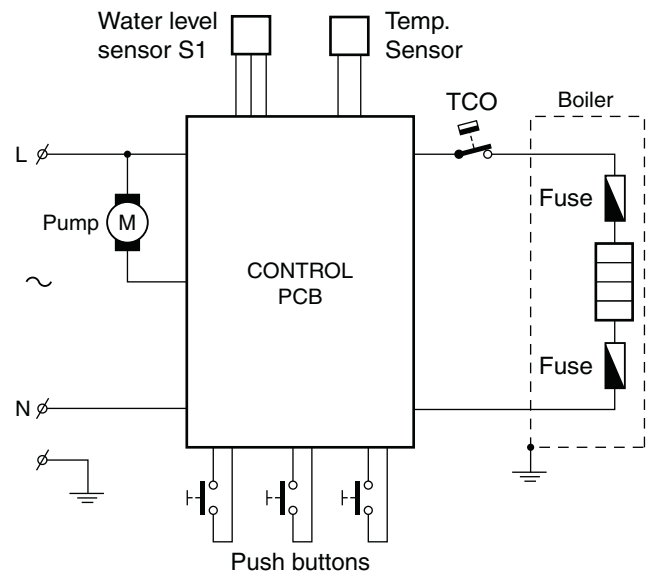

## DISASSEMBLY- AND RE-ASSEMBLY ADVISE

## HD7863/I8 / HD7864/I8

To be able to open the appliance please follow belows steps:

1. Make sure all accessories like tank, podholders, drip tray, spout, and collector are removed.
2. Remove the two screws at the backside of the appliance.
3. Place the appliance on it's back and remove the front panel by unlocking the two snap locks. (see picture)

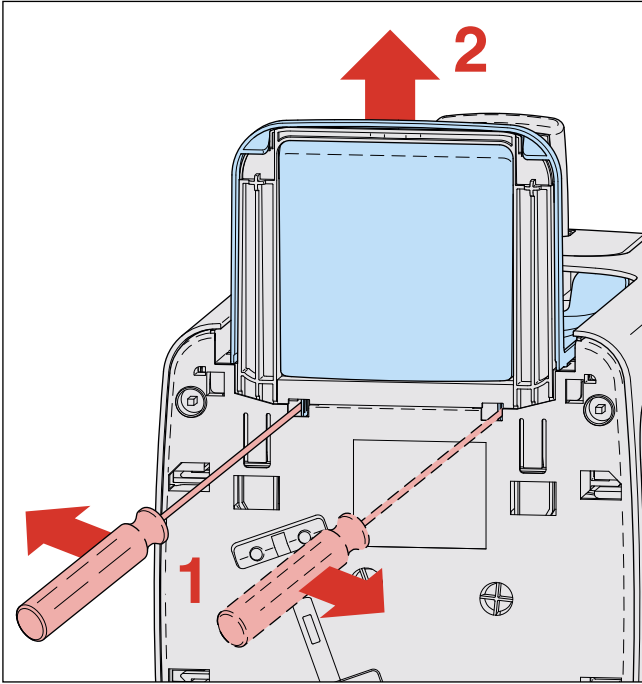

4. To remove the side panels unlock the 2 snap locks at each side and gently pull of the panels.

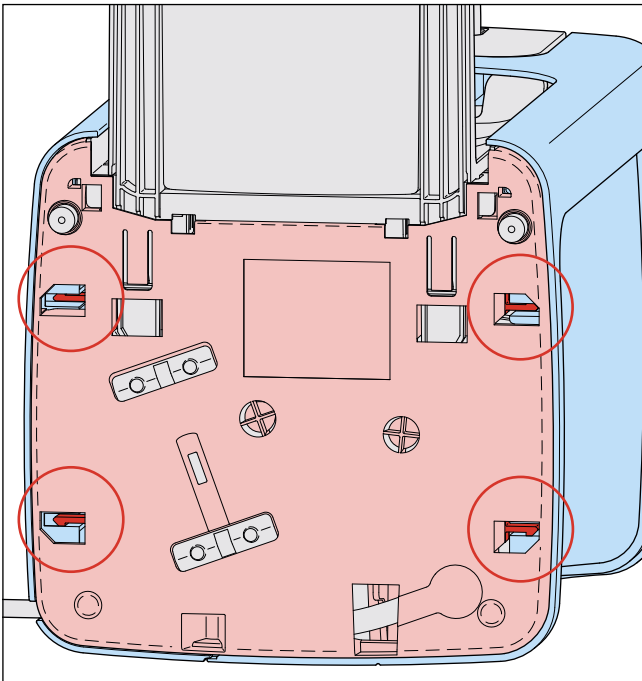

5. Once the front and side panels are removed the inner components can be reached.

To be able to reach the inner parts of the lid assy follow below steps:

1. Remove the two screws **A** which are holding the lid. (see picture)

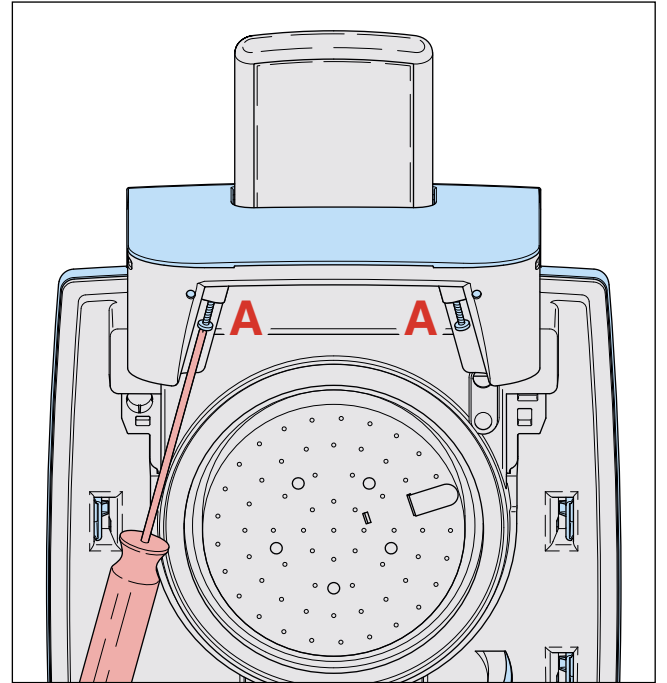

2. To remove the lid cover, start with unlocking the 4 snap locks **B**. (see picture)

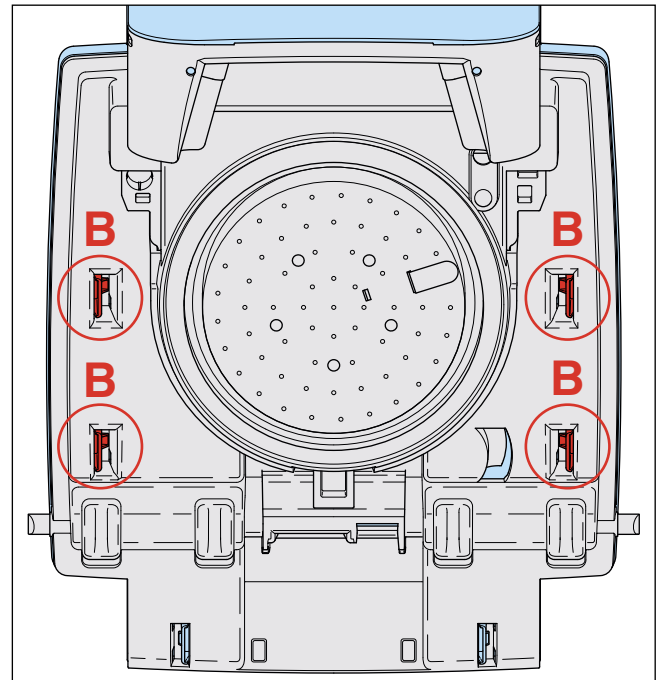

3. The lid cover is still fixed with two snap locks **C**, which can be reached with a screwdriver from the backside of the appliance. (see pictures)

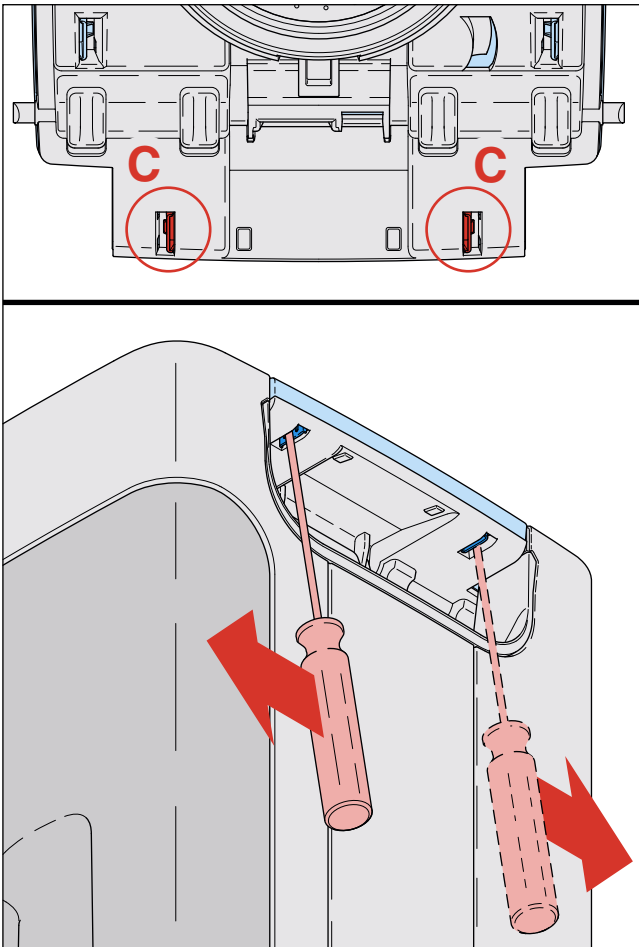

4. Once the lid cover has been removed the inner parts can be reached.
5. To reassembly, please follow steps backward.

**REPAIR INSTRUCTION**

**Descaling**

Descaling is an important element in Senseo maintenance. It should be done at least once every 3 months, up to 6 times a Year!

This will prolong the life of your appliance and will guarantee optimal brewing results for a long time.

**Use the correct descaling agent.**

Only citric acid-based descalers are suitable for descaling the SENSEO® machine. This type of descaler descales the appliance without damaging it. For the correct amount, see under 'Descaling procedure' below. Each descaling mixture can be used only once. After use, the descaling mixture is no longer active.

We advise you to use the special SENSEO® Descaler (HD7006). Read the instructions on the package of the descaling agent.

Never use a descaling agent based on mineral acids such as sulphuric acid, hydrochloric acid, sulphamic acid and acetic acid (e.g. vinegar). These descaling agents may damage your SENSEO® coffee machine.

- Follow the steps in the section headed "Descale the appliance" see DFU (Direction for Use manual)

**Volume adjustment**

The PCB circuit board makes it possible to adjust the volume output by means of pushing the one-cup and two-cup user controls.

How to adjust the volume output:

1. Be sure the boiler is filled properly, other wise perform fill procedure see DFU for instructions.
2. Switch appliance on and wait until the unit is ready to brew.
3. Be sure a **pod holder** is placed, but **without** a Coffee POD. (Only adjusting with **plain** water)
4. Place a cup on the drip tray cover and push the one-cup button.
5. When the appliance has finished it is stabilized to perform the volume adjustment.
6. Empty the cup, podholder and push again for one cup setting, measure the volume output with a graduated beaker. In the table you can find the requirements for the minimum / maximum volume output cc/mL values depending from the country version:

One-cup setting, Including Pod holder, water spec. (Without Coffee pod)		
	Min. water cc/mL	Max. water cc/mL
France version	104	120
General version	125	141

7. Unplug the appliance from the mains.
8. Press the 1- and 2 cup button simultaneously and plug the mains on.
9. When above step succeeded the led will turn on continuously.
10. Depending if the volume has to de- or increase you have to push the one- or two cup button.  
Every time you push the 1- or 2 cup button the LED will turn off for 0.5 second (feedback to user) and the pump time will be shortened or lengthened for 0.5 seconds depending which button was pushed.  
**Pushing 1 cup** button pump, time will be **shorten** with 0.5 sec is approximately – 3.5 cc/mL (less coffee)  
**Pushing 2 cup** button pump, time will be **lengthen** with 0.5 sec is approximately + 3.5 cc/mL (more coffee)  
When the volume has to increase with 10 cc for example, push the **2 cup** button 3 times.  
The new value will be stored when you switch the appliance off by **pushing** the main switch.  
(LED will turn off)
11. Turn appliance on again and brew one cup, measure the volume. In case the volume is not within specification repeat steps 6 - 11.
12. End.

**Automatic filling procedure:**

The Senseo PCB contains a automatic filling procedure software routine.

This fill routine is only meant for **back-up**.

Normally the consumer has to follow the guidelines stated in the DFU.

The filling procedure functions as follows:

The consumer has to fill the water container and has to plug the appliance on the mains.

When the Senseo main switch has been pushed the main switch LED will light continuously. This is only the case when the Senseo has not finished the filling procedure completely! (**First use**)

When the consumer pushes the one or two-cup button, the Senseo will start automatically the pump to fill the boiler.

When the boiler is filled the pump stops pumping. (Pump time approximately 22 seconds)

When the filling procedure has been successful the software will clear a **Boiler\_empty\_flag** in the Eeprom.

By means of this **Boiler\_empty\_flag** the system knows the boiler is filled or not!

When the Senseo is switched off or disconnected from the mains, the value of the **Boiler\_empty\_flag** is stored in the Eeprom chip.

**Restoring the Boiler\_empty\_flag to production default:**

Some times it is needed that the boiler of the Senseo have to be emptied.

This for instance in wintertime were the possibility exists that the boiler becomes frozen during transport e.g.

For those occasions it is handy to restore the **Boiler\_empty\_flag** again to production default.

Bringing the Senseo back into production status, has the benefit the flush routine will be activated automatically when installed by the consumer, see topic **Automatic filling procedure**.

To SET the **Boiler\_empty\_flag** can be done by:

**Keep the 1-cup button pressed while plugging in the power cord of the appliance.**

The main switch LED will blink very rapidly for approximately 1 second.

To check if the **Boiler\_empty\_flag** is really set, you should reconnect the power cord a second time to the net and push the main switch.

The main switch LED should light continuously.

Pos	Service code	Description	Remark
1	4222 259 44211	Padholder assy 1-cup	Deep Black
2	4222 259 44221	Padholder assy 2-cup	Deep Black
3	4222 240 00460	Driptray cover	
4	4222 247 70241	Driptray	Cashmere grey
5	4222 259 56281	Water container assy	Transparent
6	4222 259 56231	Lid-Button assy	Cashmere grey
7	4222 240 01410	Slider spring	
8	4222 240 05990	Ejector pin	
9	4222 247 06810	Brew chamber seal	
10	4222 247 41920	Distribution disk	
12	4222 247 61270	Spout	Deep Black
13	4222 247 70621	Spout cover	
14	4222 247 61590	Decorative spout cover	
15	4222 259 64421	Left panel	White Printed
16	4222 247 70231	Front panel	Cashmere grey
17	4222 247 61280	Collector	Deep Black
18	4222 247 70161	Right panel	White HD7863/18 only
	4222 259 55151	Right panel SS	White HD7864/18 only
19	4213 247 05256	Foot	
20	4222 247 61940	TCO cap	
21	4222 247 43690	Boiler pin cover	
22	4222 259 52091	Boiler assy TCO	V7.0 - 230 V
23	4222 259 50840	Valve assy	HD7860
24	4222 259 55911	PCB hall sensor water container	
25	4222 247 05134	NTC O-ring	
26	4222 259 39372	NTC assy	
27	4222 259 37244	Pump	ULKA HF 230 V ~50 Hz
28	4222 259 56311	PCB assy main	
29	4222 247 61310	Push rod	
32	4222 259 54991	Water container housing panel assy	White
33	4222 259 55041	Brew chamber assy	Cashmere grey

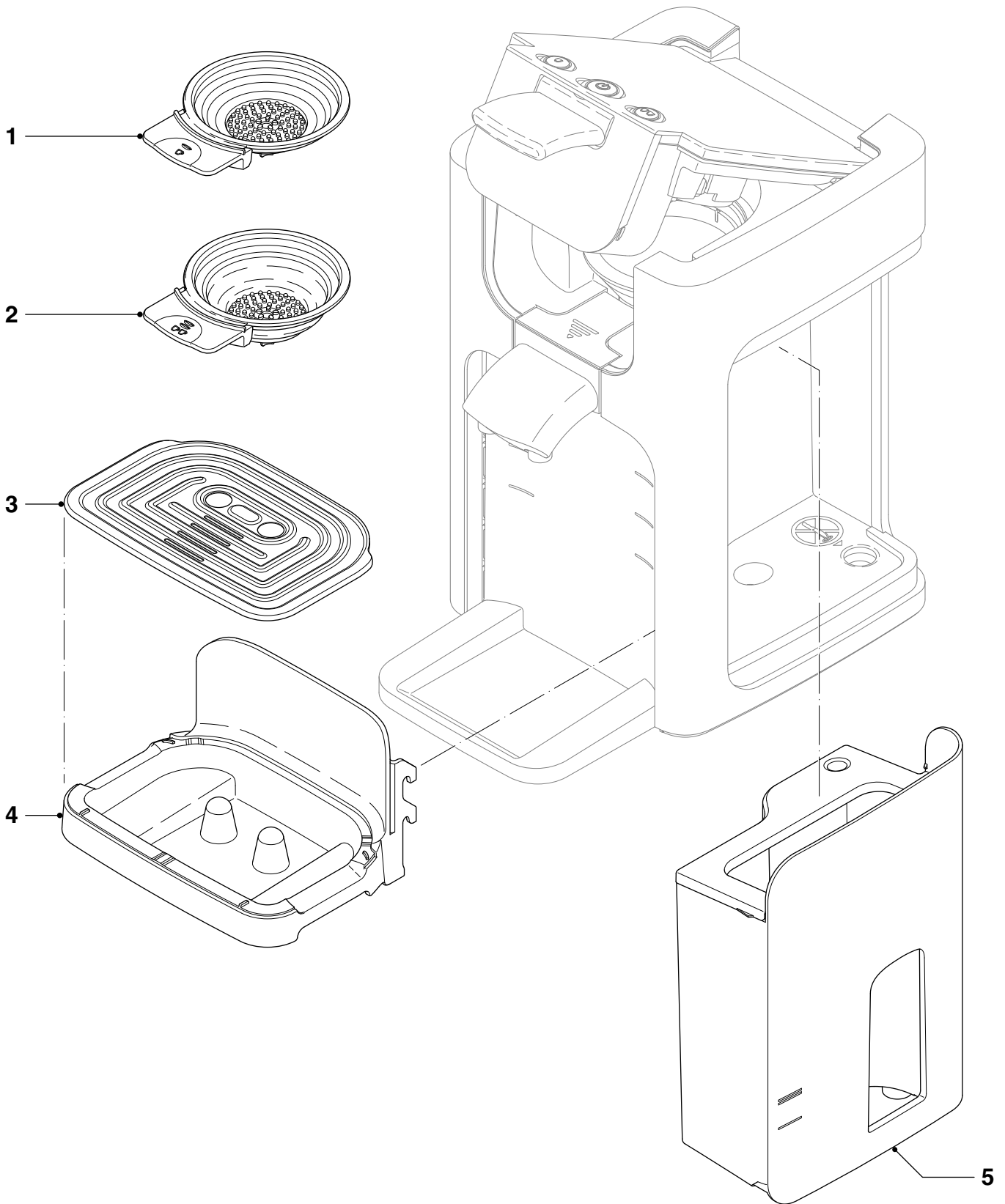

EXPLODED VIEW

HD7863/I8 / HD7864/I8

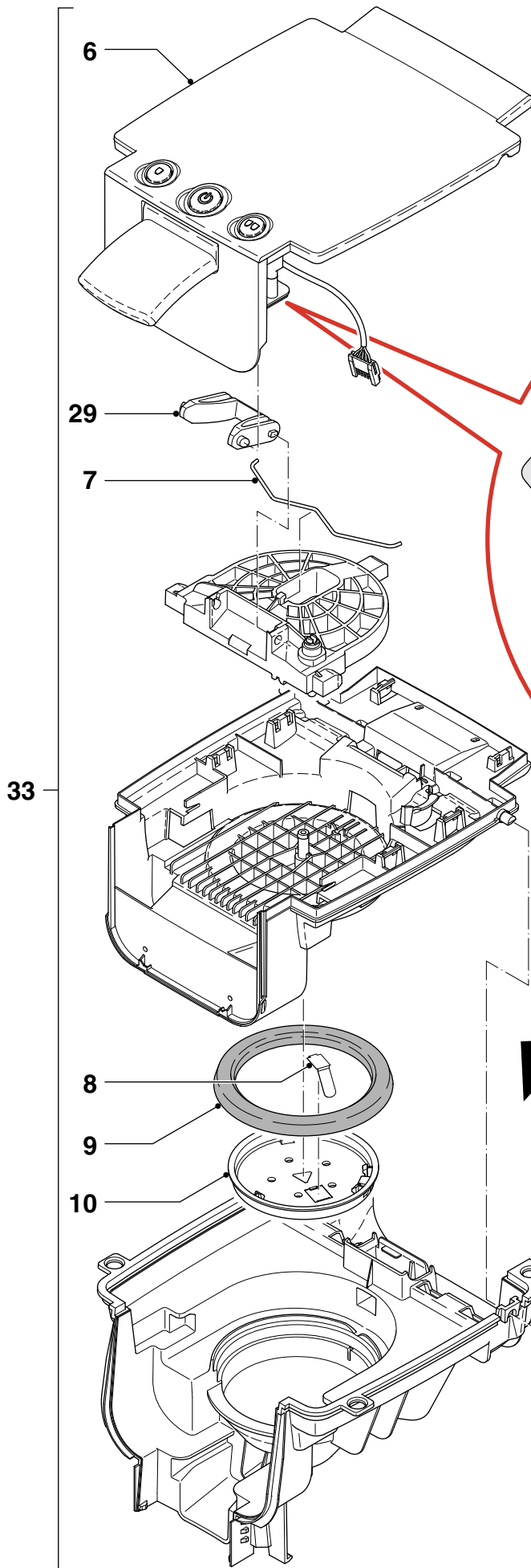

Always exchange the whole lid-button assy 6.  
**Never** unscrew the screws **D** which are holding the button case assy.  
When you do so the button case will not be air-tight anymore which can result in steam/water leakage.  
This will cause that the button assy PCB will malfunction after some use!

