

**Philips Consumer Lifestyle**

Service Manual

PRODUCT INFORMATION

- This product meets the requirements regarding interference suppression on radio and TV.
- After the product has been repaired, it should function properly and has to meet the safety requirements as officially laid down at this moment.

TECHNICAL INFORMATION

- Voltage : 220 - 240 V
- Frequency : 50 Hz
- Power consumption : 1450 W
- Standby power : <0.25 W
- Color setting : Misty Dawn & Black
- Weight : 2,05 Kg
- Dimensions H x W x D
 - Appliance : 31,5 x 24,9 x 30,8 cm
 - F-Box : 36 x 29 x 29,5 cm
- Length of cord : 80 cm
- Contents water reservoir : 930 cc (ml)

ACCESSORIES

- CRP475/01 1-cup pod holder Black
- HD5015/01 2-cup pod holder Black
- CRP860/01 Drip tray Misty dawn
- CRP862/01 Drip tray cover Black
- CRP876/01 Spout Deep black
- CRP872/01 Collector
- CRP864/01 Water container small
- CRP869/01 Water container lid Deep black

OPTIONAL (accessories)

- CRP865/01 Water container big (incl. bucket, optional Britta Filter to be purchased separately)
- CRP866/01 Water container lid (for Water container big)

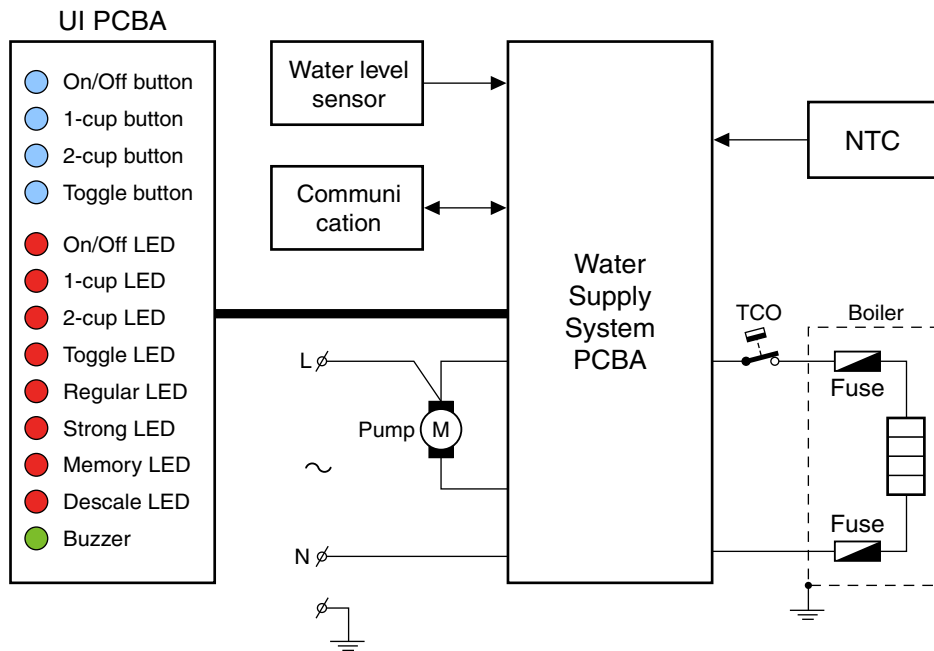

DISASSEMBLY- AND RE-ASSEMBLY ADVISE

⚠ Before you start dismantling! For your safety be sure the plug is disconnected from the mains! The product is designed for easy access to the internal components. Make sure that all accessories like tank, pod holder, drip tray, spout and collector have been removed.

To remove the back cover (31):

Place the appliance facing its backside. Using a small screwdriver remove screw cover (28) and unscrew both screws **A**. You can now remove the back cover from the appliance, please be aware that the Water level sensor (32) is still attached to the back cover.

To remove the brewhead lid cover:

Place a screwdriver on the positions (see picture) and work your way to the bottom. Please be aware that due to the construction of the brewhead, the space inside is limited. There is a chance Hose (a) will come off the pillar when opening the brewhead (22).

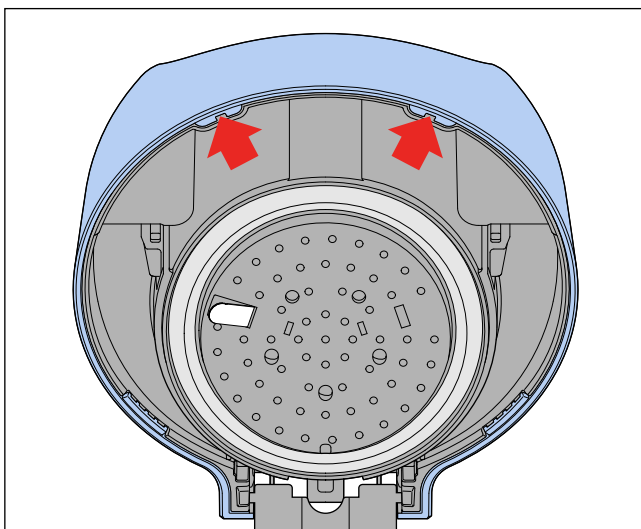

Caution, the hinge spring on the back side of the appliance may come out when the brewhead lid cover is being removed. When reinstalling it, mind your fingers as this is a strong spring.

To remove the boiler (24):

Caution the boiler may still be hot!

- Remove the back cover.
- Disconnect the Hose (a) to the brewhead.
- Unhook the 3-way valve (27) from its seat on the bottom of the brewhead.
- Unhook the boiler from the snap hook on the bottom of the brewhead.
- Disconnect the following leads:
 - (x) Boiler +
 - (y) Boiler -
 - (w) Earth
- Remove Hose (b) from the bottom side of the boiler. The boiler will not drain as long as the 3-way valve is still connected to the top. You can now safely remove the boiler from the appliance.

Note:

Please note, after replacing the boiler the appliance has to be restored to factory default. The filling procedure (cold flush), known from the predecessor Senseo's is no longer available after the flush before first use has been executed. When the "restore to factory default" procedure is not carried out, a new and empty boiler can be switched on, without having the protection of the initial flush procedure, causing the thermal fuses in the heating element to fail. After a boiler replacement or drained system, carry out the "Boiler reset" procedure! Then the initial flush procedure can be carried out.

To remove the brewhead assembly:

- Remove the back cover.
- Remove the boiler, or simply lay it aside.
- Use both thumbs to push the brewhead upwards; you may need to tilt the brewhead forward to remove it from the appliance.

To remove the PCB assembly (34):

- Remove the back cover
- Remove the boiler
- Remove the brewhead assembly
- Remove the Main PCBA cover (33)
- Disconnect the following leads:
 - NTC (flat cable)
 - Water level sensor (flat cable)
 - (z) UI PCBA (flat cable)
 - (s) Live
 - (t) Pump
 - (u) Neutral
 - (v) Earth
- You can now unhook the snap hooks holding the PCBA in place.

To access components located in the base of the appliance (UI Panel, Pump, Water container interface)**Open the Base:**

- Remove the back cover
- Remove the boiler
- Remove the brewhead assembly
- Remove the Main PCBA cover (33)
- Remove the PCB assembly
- Unscrew the two screws (B) holding the Front housing (23) in place. Remove the front housing
- Take the base of the appliance, using a small screw driver start at the point indicated in the picture. Gently push it between the tray panel assembly (36) and base plate (41), the hidden snap should click open.

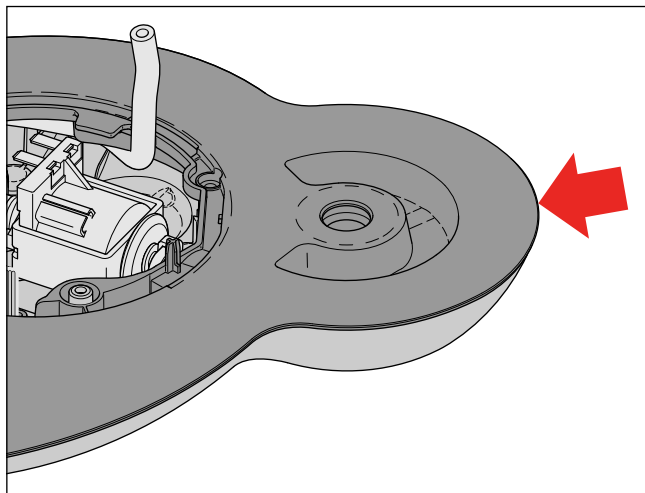

- Undo the two click connections visible on the bottom side of the appliance.

- Now use the screwdriver to trace around the edge of the tray panel assembly and base plate until you reach the position of the drip tray. Repeat the process for the other side. All snap hooks will come undone.

Please note that the water container interface is still connected to the tray panel assembly and to the pump on the base plate

To access the capacitive UI PCBA:

- Remove the back cover
- Remove the boiler
- Remove the brewhead assembly
- Remove the Main PCBA cover (33)
- Remove the PCB assembly
- Unscrew the two screws (B) holding the Front housing (23) in place. Remove the front housing
- Open the Base
- Turn the Tray panel assembly upside down and open the clicks of the UI PCBA Cover
- Here you will find:
 - UI PCBA (38)
 - UI Panel frame
 - Light distributor

Descaling

Descaling is an important element in Senseo maintenance. It should be done at least once every 3 months, up to 6 times a Year! This will prolong the life of your appliance and will guarantee optimal brewing results for a long time. Use the correct descaling agent. Only citric acid-based descalers are suitable for descaling the SENSEO® machine. This type of descaler descales the appliance without damaging it. For the correct amount, see the instructions in the packaging of the descaler.

We advise you to use the special SENSEO® Descaler (HD7011 or HD7012). Read the instructions on the package of the descaling agent. Never use a descaling agent based on mineral acids such as sulphuric acid, hydrochloric acid, sulphamic acid and acetic acid (e.g. vinegar). These descaling agents may damage your SENSEO® coffee machine. Follow the steps in the section headed "Descale the appliance" see DFU (Direction for Use manual).

Please note, as the appliance is equipped with a capacitive touch panel as a user interface, special attention is required to be able to enter several service modes. The capacitive buttons need 0,5 seconds to initialize after the mains is connected. During this timeslot the capacitive buttons must not be touched, otherwise you will not be able to enter the service modes.

Service mode

The appliance is equipped with a dedicated service mode. The service mode enables you to carry out some settings and tests.

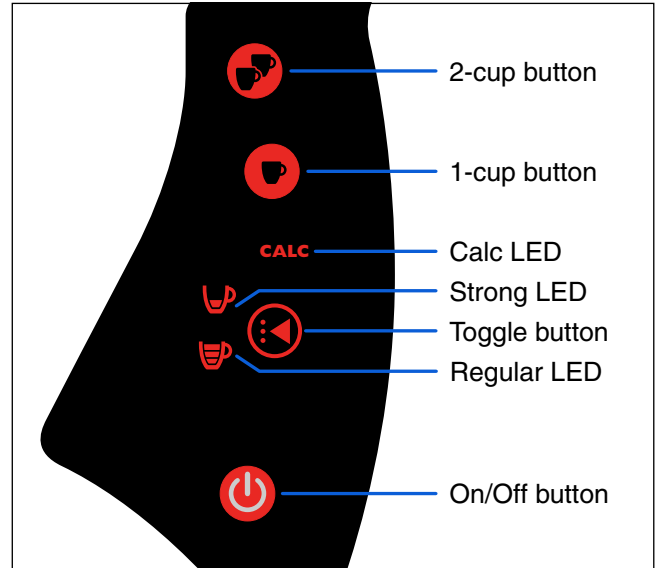

Service mode																																							
Press the indicated button after connecting the mains																																							
1-cup button	Boiler reset	<p><i>Only in case of a reset appliance you can check it's current settings. When connecting the appliance to the mains, you should see the On/Off light blinking very rapidly for 0.5 seconds. For convenience the country selection and ME/HE selection are also being displayed.</i></p> <table border="1"> <thead> <tr> <th colspan="2">Boiler_empty_flag set</th> <th></th> <th>Blinking</th> </tr> </thead> <tbody> <tr> <td rowspan="2">Country Selection</td> <td>General version</td> <td></td> <td>Off</td> </tr> <tr> <td>France / Spain version</td> <td></td> <td>Blinking</td> </tr> <tr> <td rowspan="2">ME / HE Selection</td> <td>Mid-end</td> <td></td> <td>Off</td> </tr> <tr> <td>High-end</td> <td></td> <td>Blinking</td> </tr> </tbody> </table>	Boiler_empty_flag set			Blinking	Country Selection	General version		Off	France / Spain version		Blinking	ME / HE Selection	Mid-end		Off	High-end		Blinking																			
Boiler_empty_flag set			Blinking																																				
Country Selection	General version		Off																																				
	France / Spain version		Blinking																																				
ME / HE Selection	Mid-end		Off																																				
	High-end		Blinking																																				
1 & 2-cup button	Settings	<pre> graph TD Settings[Settings] --> Calibration[Manual pump calibration (Volume adjustment)] Calibration --> Selection[Mid-End / High-End Selection (to enable Personal Coffee Memory button)] Selection --> Country[Country Selection (General / France-Spain)] Country --> Off[Off] </pre>																																					
2-cup button	Sensor & LED test	<table border="1"> <thead> <tr> <th>Sensor</th> <th>LED</th> <th>LED on</th> <th>LED off</th> </tr> </thead> <tbody> <tr> <td>On/Off button</td> <td>On/Off LED</td> <td>Button pressed</td> <td>Button released</td> </tr> <tr> <td>1-cup button</td> <td>1-cup LED</td> <td>Button pressed</td> <td>Button released</td> </tr> <tr> <td>2-cup button</td> <td>2-cup LED</td> <td>Button pressed</td> <td>Button released</td> </tr> <tr> <td>Toggle button</td> <td>Toggle LED</td> <td>Button pressed</td> <td>Button released</td> </tr> <tr> <td>NTC boiler</td> <td>Descale LED</td> <td>NTC error</td> <td>NTC ok</td> </tr> <tr> <td>Water level sensor</td> <td>Regular LED</td> <td>Water present</td> <td>Water low</td> </tr> <tr> <td>-</td> <td>Strong LED</td> <td><always on></td> <td>-</td> </tr> <tr> <td>-</td> <td>Memory my cup LED</td> <td><always on></td> <td>-</td> </tr> </tbody> </table>		Sensor	LED	LED on	LED off	On/Off button	On/Off LED	Button pressed	Button released	1-cup button	1-cup LED	Button pressed	Button released	2-cup button	2-cup LED	Button pressed	Button released	Toggle button	Toggle LED	Button pressed	Button released	NTC boiler	Descale LED	NTC error	NTC ok	Water level sensor	Regular LED	Water present	Water low	-	Strong LED	<always on>	-	-	Memory my cup LED	<always on>	-
Sensor	LED	LED on	LED off																																				
On/Off button	On/Off LED	Button pressed	Button released																																				
1-cup button	1-cup LED	Button pressed	Button released																																				
2-cup button	2-cup LED	Button pressed	Button released																																				
Toggle button	Toggle LED	Button pressed	Button released																																				
NTC boiler	Descale LED	NTC error	NTC ok																																				
Water level sensor	Regular LED	Water present	Water low																																				
-	Strong LED	<always on>	-																																				
-	Memory my cup LED	<always on>	-																																				

BOILER RESET:**Boiler-reset-step 0 Entry to boiler reset mode:**

1. Connect mains;
2. After 0.5 second and before 1.5 second operate the 1-cup button.
3. Release all switches.

SETTINGS:**Manual pump calibration**

Please note that the volume adjustment to compensate for a different country execution is now split in Volume adjustment (calibrate Regular coffee cup volume) and the Country selection (set the corresponding Strong coffee cup volume).

Service-step 0 Entry to calibration mode:

1. Connect mains;
2. After 0.5 second and before 1.5 second operate the 1-cup and 2-cup buttons simultaneously.
On/off, 1-cup and 2-cup LEDs will be switched ON.
3. Release all switches.

Service-step 1A Decrease calibration value:

1. Push (and release) the 1-cup button to decrease the calibration value.
The On/Off LED will be OFF for 0.5 seconds.
2. Repeat step 1A.1 when required.

Service-step 1B Increase calibration value:

1. Push (and release) the 2-cup button to increase the calibration value.
The On/Off LED will be OFF for 0.5 seconds.
2. Repeat step 1B.1 when required.

Service-step 2 Store calibration value:

1. Operate the On/Off button.
On/Off LED will blink fast for 1.0 seconds and the calibration value is stored.
2. Release all switches.
The On/Off and 1-cup LED will be ON.
The memory LED will be OFF when ME is selected and ON when HE is selected.

ME/HE selection

In this appliance ME (Mid-End) should be selected; Strong LED off.

Service-step 3 Change HE/ME selection value:

1. Push (and release) the 1-cup button to change the HE/ME value.
The strong LED will be OFF when ME is selected and ON when HE is selected.
2. Repeat step 3.1 when required.

Service-step 4 Store HE/ME selection value:

1. Operate the On/Off button.
On/Off LED will blink fast for 1.0 seconds and the HE/ME value is stored.
2. Release all switches.
The On/Off LED will be OFF.

Country selection**Service-step 5 Change country selection value:**

1. Push (and release) the 2-cup button to change the country value.
The regular LED will be OFF when a European selection is selected and ON when a France selection is selected.

Note that when changing the country selection the pump needs to be recalibrated again with a defined pump time.

2. Repeat step 5.1 when required.

Service-step 6 Store country selection value:

1. Operate the On/Off button.
On/Off LED will blink fast for 1.0 seconds and the country selection value is stored.
2. Release all switches
The On/Off LED will be OFF.

When settings have been changed to change the coffee volume (Manual pump calibration or Country selection), the appliance needs to be unplugged from the mains before the new settings will take effect.

SENSOR AND LED TEST

To validate the assembly and electrical correctness of an appliance, especially during testing and debugging phase, a sensor and LED test is very useful. Please keep in mind that it is not an automated test and only intended as indication.

Service-step 0 Entry to test mode:

1. Connect mains;
2. After 0.5 second and before 1.5 second operate the 2-cup button.
3. Release all switches.
4. All LEDs will be ON for 1.0 seconds and after that switch to OFF again.

Service-step 1 Sensor identification:

1. Manually operate a button or sensor.
The related LED - refer to the table on p.4 - will be ON.
2. Release the button or sensor.
The related LED - refer to the table on p.4 - will be OFF.

Service-step 2 End test

1. Disconnect mains → end test program

PCBA REPLACEMENT

 **When there is the need for a PCBA replacement the default setting of the PCBA will be:**

- Boiler empty flag = SET
- ME/HE selection = Mid end
- Country selection = General version

Please follow below way of working.

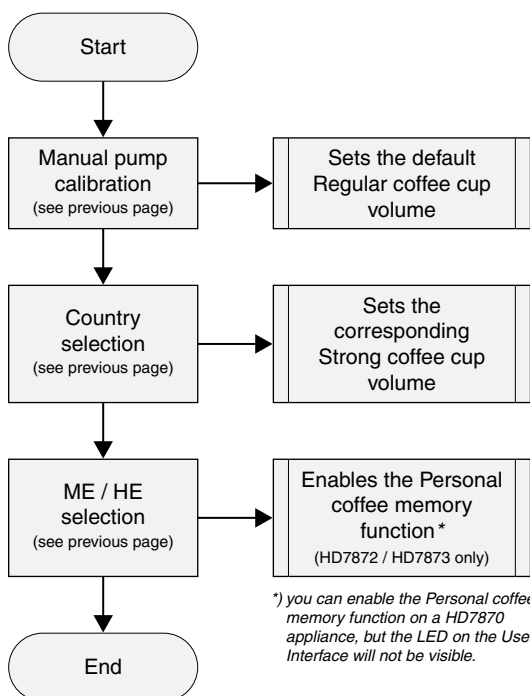

Volume adjustment

The PCB circuit board makes it possible to adjust the volume output by means of pushing the one-cup and two-cup user controls. How to adjust the volume output:

1. Make sure the boiler is filled properly, otherwise perform fill procedure see DFU for instructions.
2. Switch appliance on and wait until the unit is ready to brew.
3. Make sure a pod holder is placed, but without a Coffee POD. (Only adjusting with plain water)
4. Place a cup on the drip tray cover and push the one-cup button.
5. When the appliance has finished it is stabilized to perform the volume adjustment.
6. Empty the cup, pod holder and push again for one cup setting, measure the volume output with a graduated beaker. In the table you can find the requirements for the minimum / maximum volume output cc/mL values depending from the country version:

One-cup setting, Including Pod holder, water spec. (Without Coffee pod)		
	Min. water cc/mL	Max. water cc/mL
French / Spanish version	101	121
General version	123	143

7. Unplug the appliance from the mains.
8. Press the 1- and 2 cup button simultaneously and plug the mains on.
9. When above step succeeded the LED will turn on continuously.
10. Depending if the volume has to de- or increase you have to push the one- or two cup button. Every time you push the 1- or 2 cup button the LED will turn off for 0.5 second (feedback to user) and the pump time will be shortened or lengthened for 0.5 seconds depending which button was pushed.
Pushing 1 cup button pump, time will be shorten with 0.5 sec is approximately – 3.5 cc/mL (less coffee).
Pushing 2 cup button pump, time will be lengthen with 0.5 sec is approximately + 3.5 cc/mL (more coffee).
 When the volume has to increase with 10 cc for example, push the 2 cup button 3 times. The new value will be stored when you switch the appliance off by pushing the main switch (LED will turn off).
11. Turn appliance on again and brew one cup, measure the volume. In case the volume is not within specification repeat steps 6 - 11.

Note:

Changing a newly installed PCBA (by default delivered with General version settings) into a French or Spanish setting requires a decrease of the pump time by 2,5 seconds (or five pushes of the 1-cup button).

Pos	Service code	Description	Remark
1	4222 259 4421 I	Pad support 1-cup	Deep black
2	4222 259 4422 I	Pad support 2-cup	Deep black
3	4222 247 6750 I	Collector	Deep black
4	4222 259 53432	Spout assy complete	Deep black
5	4222 247 6775 I	Drip tray cover	Deep black
6	4222 247 6749 I	Drip tray	Lime yellow
7	4222 259 5294 I	Water container assy complete	Transparent
8	4222 247 6824 I	Water container lid	Deep black
14	4222 247 6822 I	Lid window	Misty dawn
15	4222 247 6821 I	Lid cover	Deep black
16	4222 247 6819 I	Lever	Deep black
17	4222 247 6759 I	Pushrod	
18	4222 240 01413	Spring	
19	4222 247 06814	Brew chamber seal	
20	4222 240 0599 I	Ejector pin	
21	4222 247 41922	Distribution disk	
22	4222 259 53413	Brew chamber assy	Deep black
23	4222 247 6828 I	Front housing	Deep black
24	4222 259 5209 I	Boiler assy	
25	4222 247 05134	NTC O-ring	
26	4222 259 4730 I	NTC assy	
27	4222 259 5448 I	3-way valve	
28	4222 247 6832 I	Screw cover	Deep black
29	4222 247 6833 I	Valve outlet	Deep black
30	4222 247 6831 I	Water container catch	Deep black
31	4222 247 6829 I	Back housing	Deep black
32	4222 259 5187 I	Water level sensor	
33	4222 247 6743 I	Main PCBA cover	
34	4222 259 51853	Main PCBA assy	
35	4222 247 0659 I	Pressure hose	
36	4222 259 52912	Tray panel assy complete	Mystery black
37	4222 248 5662 I	UI sticker	ME
38	4222 259 52833	UI PCBA	
39	4222 247 6772 I	UI PCBA Cover	
40	4222 259 37244	Pump	
41	4222 247 6827 I	Base plate	Misty dawn
42	4213 247 05256	Foot	

EXPLODED VIEW

HD7870/60 161 162

