

Service Service Service

New Royal and Gran Crema



Service Manual

Revision 02 January 2013

Table of contents	Page	Table of contents	Page
1. Introduction		4.8. Water level detection (water tank)	7
1.1. Documentation required	1	4.9. Descaling request	7
1.2. Tools and equipment required	1	4.10. Water filter	8
1.3. Material	1		
1.4. Safety warnings	1	5. Troubleshooting	
1.5. Service Policy	2	5.1.1. Test mode New Royal	1
1.6. External machine parts	3	5.1.2. Diagnostics mode New Royal	5
1.7. Internal machine parts	4	5.2. Test mode Royal Gran Crema	7
		5.3. Error messages	10
2. Technical specifications			
2.1. Technical specifications	1	6. Standard checks	
2.2. Specification for the measurement of the coffee products temperature.	2	6.1. Repair schedule	1
2.3. Machine parameters and performance	3	6.2. Service schedule	1
		6.3. Final test	2
3. User instructions			
3.1.1. Customer and programming menu	1	7. Disassembly	
3.1.2. Machine indications	3	7.1. Outer elements	1
3.2.1. Customer and programming menu in Royal Gran Crema	4	7.2. Coffee grinder	1
3.2.2. Machine indications in Royal Gran Crema	5	7.3. Grinder blades	2
3.3. Operation, cleaning and maintenance	6	7.4. Coffee grinder motor	3
		7.5. Doser hatch, coil and microswitch	3
4. Operating logic		7.6. Doser hopper	3
4.1. Water circuit	1	7.7. Coffee boiler and steam boiler	4
4.2. Frother unit valve assembly	3	7.8. Boiler pin	4
4.3. Cappuccino maker assembly	3	7.9. Coffee pump and steam pump	4
4.4. Relief valve	4	7.10. Flow meter	5
4.5. Coffee cycle	5		
4.6. Single microswitch	6		
4.7. Temperature sensor	6		

All parts of this document are the property of Saeco International Group.

All rights reserved. This document and all the information herein is provided without liability deriving from any errors or omissions. Furthermore, no part may be reproduced, used or collected, except where express authorization has been provided in writing or through a contractual agreement.

Published by Saeco International Group
013

Subject to modification

EN 4219 400

2011-July-08

Table of contents		Page
7.11.	Gear motor	5
7.12.	Relief valve	6
7.13.	Solenoid valve assembly	6
7.14.	Steam pipe assembly	7
7.15.	Dispenser assembly	7
7.16.	Power board	7
7.17.	Display, keypads and control board	8
7.18.	Fitting and removing Oetiker clamps	9
8.	Notes	
9.	Water circuit diagram	
10.	Electrical diagram	



CHAPTER 1

INTRODUCTION

1.1. Documentation required

The following documentation is needed for repair procedures:

- Instruction booklet for specific model.
- Technical documentation for specific model (diagrams, exploded view, symptom cure and service manual).

1.2. Tools and equipment required

As well as the standard equipment, the following is required:

Qty.	Description	Notes
1	Screwdriver	Torx T 8 - T 10 - T 20
1	Screwdriver	Cross-head
1	Pliers for Oetiker clamps	
1	CC -A - Vdc tester	
1	Digital thermometer	Scale limit > 150°C
1	SSC (Saeco Service Center)	Programmer (for programming and diagnostics mode)

1.3. Material

Description	Notes
Thermal paste	Heating element > 200°C
Descaler	Saeco descaler
Grease solvent	Personal choice
Silicone grease	Safe to use with food

1.4. Safety warnings

We recommend you consult this Service Manual of the machine before performing any maintenance work.

Observe all applicable standards relating to the repair of electrical appliances.

Always disconnect the power plug from the mains before beginning repair work.

Simply turning off the main machine power switch is not an adequate safety precaution.

This domestic appliance is rated as insulation class I.

On completion of the repair work, insulation and dielectric rigidity tests must be performed.

1.5 Service POLICY grid as used for coffee machine

For IN WARRANTY repairs is mandatory to use the single components (not the assembly) available in the exploded views of the coffee machines or of the specific components. If you find the information "SEE THE EXPLODED VIEW E....." in the assembly description field, it means that the single components of the assembly are available in the other pages of the exploded view. It's possible to use the assembly only if there is a specific Symptom Cure that include this possibility or when the single components are not available for the order.

List of principal assembly present in all our coffee machines

Components	Assembly use	Single components available
COFFEE GRINDER	<u>Only for OOW repairs</u>	YES , to consult the specific exploded-view of the machine or of the Coffee Grinder on website
BREWING UNIT	<u>Only for OOW repairs</u>	YES , to consult the specific exploded-view of the machine or of the Brewing unit on website
BOILER	<u>Only for OOW repairs</u>	YES , to consult the specific exploded-view of the machine on website
GEAR MOTOR	<u>Only for OOW repairs</u>	YES , to consult the specific exploded-view of the machine on website
FILTER HOLDER	<u>Only for OOW repairs</u>	YES , to consult the specific exploded-view of the machine on website
MILK CARAFE	<u>Only for OOW repairs</u>	YES , to consult the specific exploded-view of the machine on website
THERMAL CARAFE	<u>Only for OOW repairs</u>	YES , to consult the specific exploded-view of the Thermal Carafe on website
MILK ISLAND	<u>Only for OOW repairs</u>	YES , to consult the specific exploded-view of the Milk Island on website

1.6. External machine parts

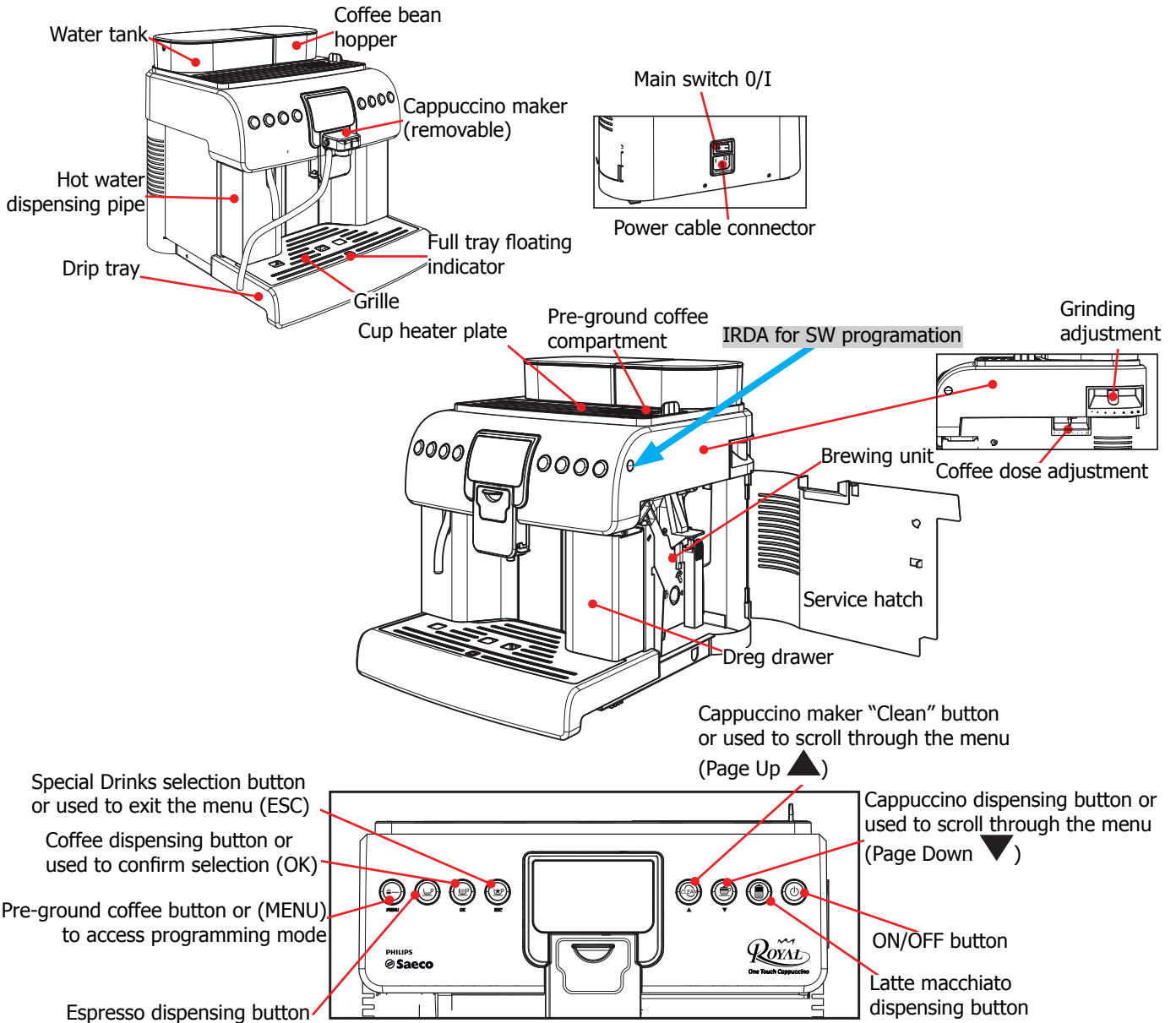

Gran Crema

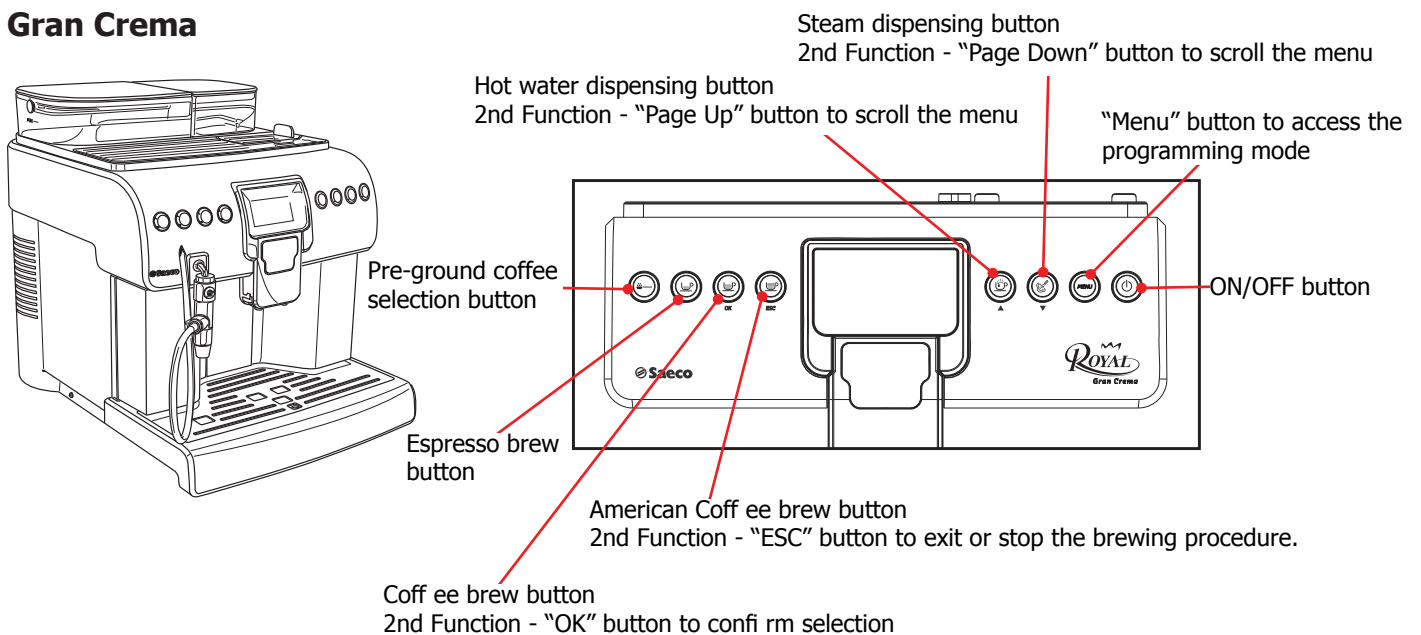

1.7. Internal machine parts

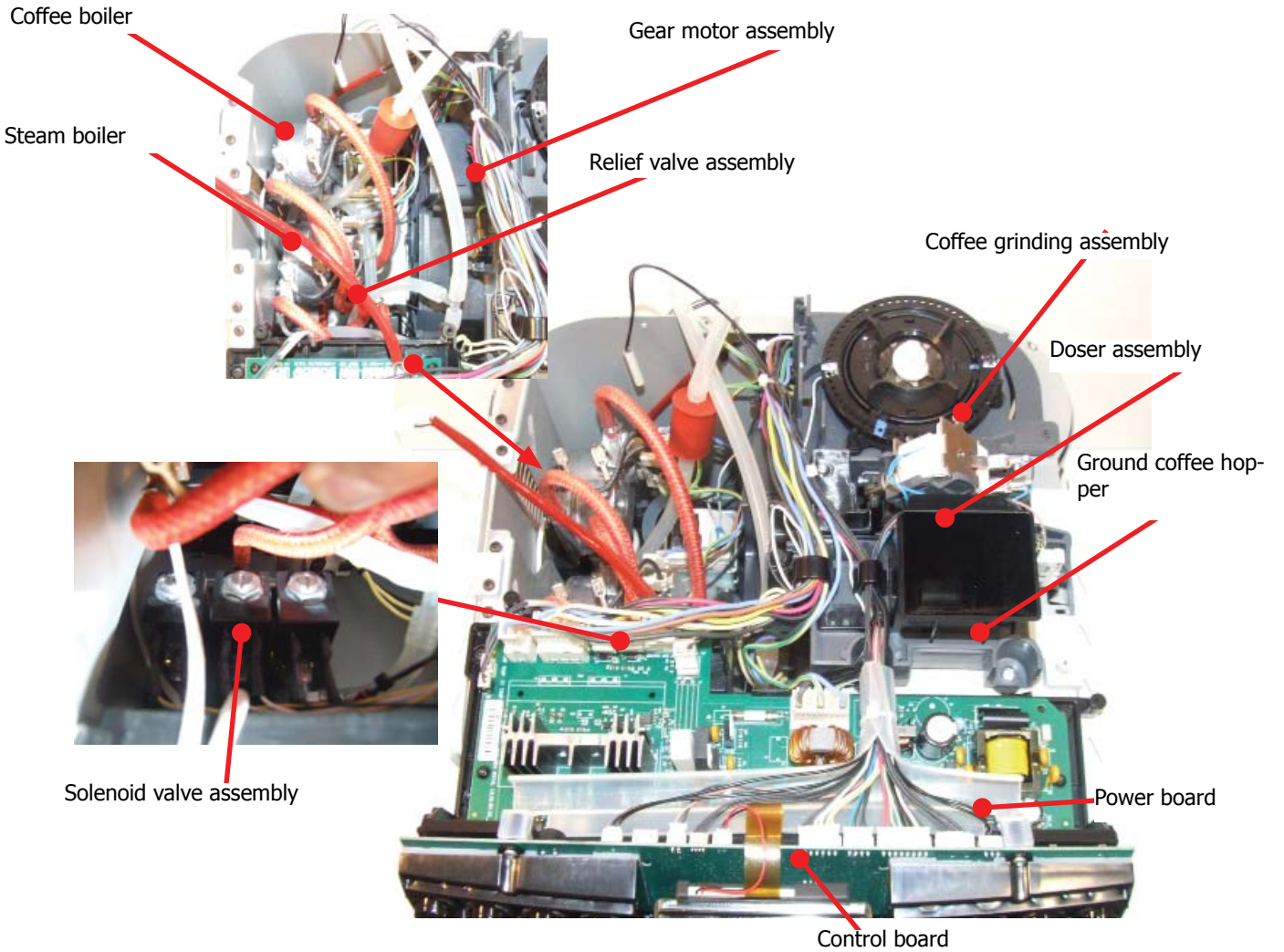

Gran Crema

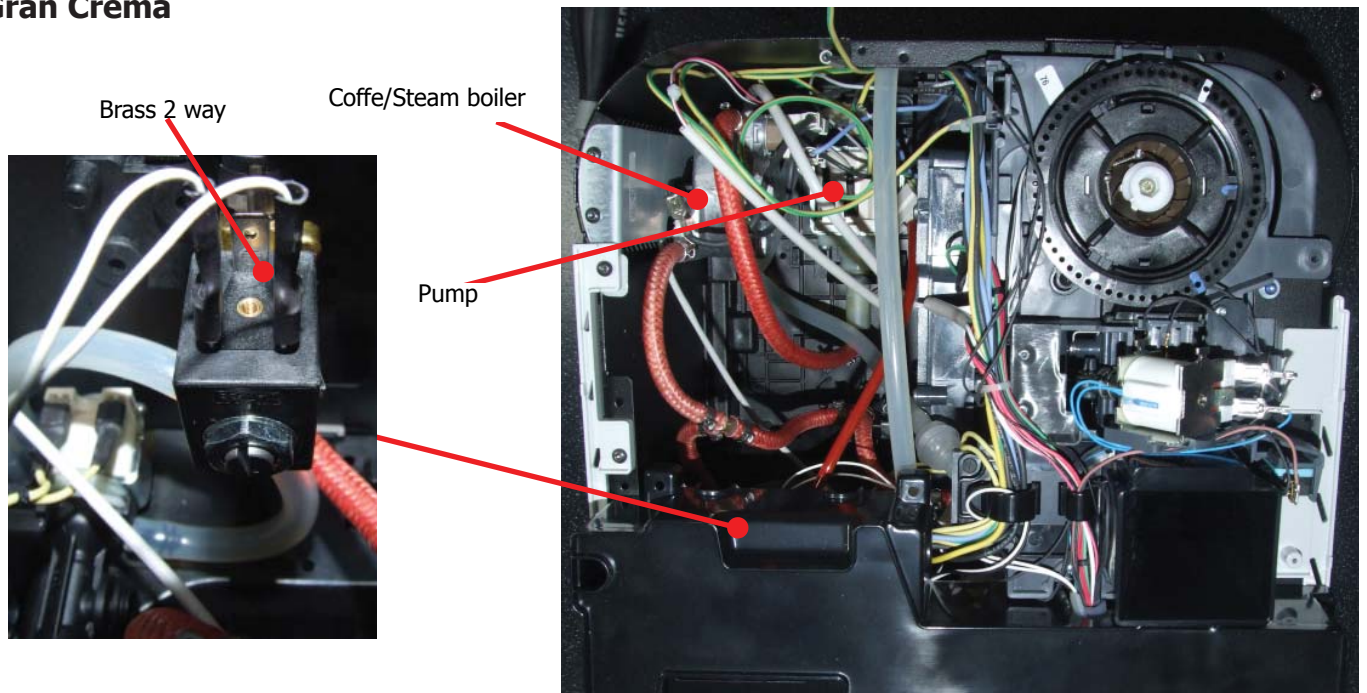



CHAPTER 2

TECHNICAL SPECIFICATIONS

2.1. Technical specifications

Power supply and output:	New Royal 240 V~ 50/60 Hz 1300 W - 230 V~ 50/60 Hz 1300 W 120 V~ 60 Hz 1300 W - 100 V~ 50/60 Hz 1300 W Gran Crema 240 V~ 50/60 Hz 1900 W - 230 V~ 50/60 Hz 1900 W 120 V~ 60 Hz 1900 W - 100 V~ 50/60 Hz 1900 W
Temperature monitoring:	(NTC) variable resistor sensor - transmits the value to the electronic card
Safety system:	2 thermostats at 190°C one shot
Gear motor:	2 rotation directions; power supply 24VC
Coffee pump	Ulka Type EP5/S GW approx. 13-15 bar with reciprocating piston and thermal switch 120°C 48 W, 230V, 50 Hz,
Steam pump	Ulka HF with reciprocating piston 230V, 50 Hz and thermal switch 120°C - 22W
Overpressure valve: (multi-way valve)	Opening at approx. 19-23 bar
Water filter:	In tank
Coffee grinder:	Direct current motor with conical steel grinder blades
Power consumption:	During heating phase- approx. 5.6 A
Consumption in Standby	< 0.3 W
Dimensions: W x H x D in mm:	336x380x450
Weight:	16 kg
Water tank capacity:	2.2 l
Coffee bean hopper capacity:	320 g. of coffee beans
Dreg drawer capacity:	19 (18+1)
Heat exchanger capacity:	Approx. 10 cc
Water circuit filling time:	Approx. 50 sec Max. on first filling cycle including rinsing
Heating time:	Approx. 25 sec. Max. in stand-by
Grinding time:	Approx. 4-7 sec.

2.2. Specification for the measurement of the coffee products temperature.

The temperature is influenced by the flow from the dispenser and stratification of temperatures in the glass. In order to consider these phenomena and to introduce measures that allow comparisons in controlled conditions, below guidelines must be followed:

Conditions:

- a) Water temperature in tank: 23°C (+/-2°C).
- b) It must be used a plastic cup (see picture N°1).
- c) It must be used a thermocouple thermometer (e.g. type K - see picture N°2).
- d) The coffee machine is tested without any change of parameters or calibrations, which may affect the temperature of products, so the measurement of temperature must be done with machine in default factory setting.

Procedure:

1. The temperature must be measured in the cup, immediately after dispensing. Cup has to be placed on a non-metal surface using a thermocouple thermometer.
2. The temperature in the cup is measured by immersing the probe of the thermometer up to touch the bottom. The probe then must be moved in a circular motion for 5/6 rotations. At the end of the rotations, stop in the center of the cup.
3. The highest temperature measured during the rotations is the value we are searching for, and that must be reported;
4. Test measurement: from end of dispensing to the end of rotations must be completed within 12 seconds.

Limits of acceptability

The acceptance limits are divided by features and products and are the following:

Espresso Coffee Italy Q.ty 25/40 gr.

Temperature of 1st product 69°C ≤ 85°C

Temperature of 2nd product 72°C ≤ 85°C

Coffee Q.ty 70/120 gr.

Temperature of 1st product 69°C ≤ 85°C

Temperature of 2nd product 72°C ≤ 85°C



2.3. Machine parameters and performance

PRODUCT QUANTITY	Minimum quantity (Puls.)	Default quantity (Puls.)	Maximum quantity (Puls.)	User programmable	Programm. by Production / Service
Espresso	90	130 - 170 *	200	Yes	No
Coffee	100	200 -280*	600	Yes	No
Long coffee	70	330 - 440 *	600	Yes	No
American coffee	300	-	600	Yes	No
Pre-ground	Yes				
Hot water	Continues for 400 pulses				

* Depends on the language selected by the user

RINSE	Initial rinse	Final rinse
When performed	When the machine is switched on and the boiler temperature is $\leq 50^{\circ}\text{C}$	When the machine is switched off electronically, manually or automatically after 30', if at least one coffee has been dispensed, before switching off
No. of pulses	130	100
Stopping option	Yes, by pressing any key	Yes, by pressing any key
User disable option	No	No
Production/Service department disable option	No	No
No. of pulses user adjustment option	No	No
No. of pulses Production/Service department adjustment option	No	No
Pulse range (Min. – Max.)	No	No

Descaling cycle frequency			
Hardness	Water hardness	Without water filter	With water filter
1	Soft (up to 7°dH)	240 litres (480,000 pulses)	480 litres (960,000 pulses)
2	Medium (7° - 14°dH)	120 litres (240,000 pulses)	240 litres (480,000 pulses)
3	Hard (15° - 21°dH)	60 litres (120,000 pulses)	120 litres (240,000 pulses)
4	Very hard (over 21°dH)	30 litres (60,000 pulses)	60 litres (120,000 pulses)

The default water hardness level is 4. Each litre of water corresponds to approximately 2,000 pulses.

DREG DRAWER	Description and values
Time-out for dreg drawer	5 sec.
Warning to empty dreg drawer after	Yes, after 15 lots of dregs
Empty dreg drawer blocking alarm after (double coffee is the last beverage dispensed)	18 lots of dregs (19 lots of dregs)
Reset dreg counter	The dreg drawer must be emptied only when prompted by the machine ensuring the machine is switched on and removing the drawer for more than 5 seconds.

STANDBY	Description and values
Inlet time (min. – max.)	15 minutes - 180 minutes
Inlet time (default)	30 minutes
Inlet time programmed by user	Yes
Inlet time programmed by Production/ Service	Yes
Boiler temperature during Standby	Boiler OFF
Cup heater during Standby	Cup heater OFF

WATER TANK	Description
Water reserve (pulses)	200
Water reserve modifiable by Production/Service departments	No
"Fill tank" alarm	Yes
"No tray" alarm	No
Water mains	No



CHAPTER 3

USER INSTRUCTIONS

3.1.1. Customer and programming menu in New Royal

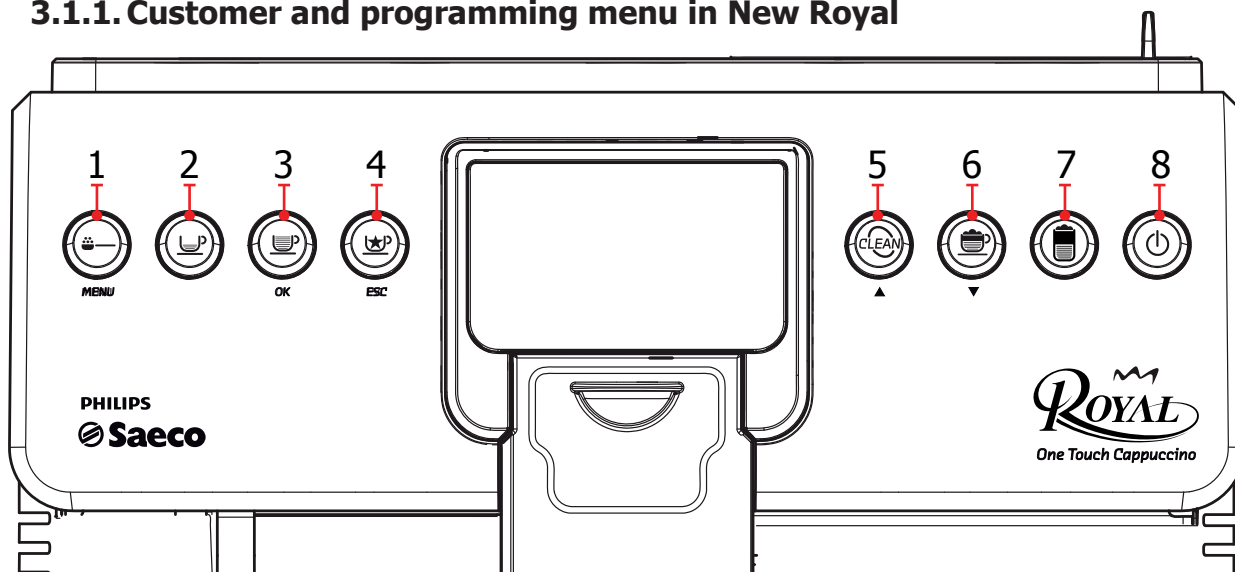

1		Pre-ground selection button - MENU This button is used to select the possibility to dispense the coffee with pre-ground coffee.	2nd function - Press for 5 seconds to access the machine programming menu.
2		Espresso dispensing button	
3		Coffee button - OK The button is used to select the type of coffee dispensing.	2nd function - Press to select the heading shown on the display.
4		Special Drinks selection button - ESC The button is used to access the list of special drinks the machine can dispense.	2nd function - Press to exit the selected page and/or exit the programming mode and/or stop the drink dispensing.
4		CLEAN button (washing) - Page UP The button is used to carry out a cleaning cycle of the cappuccino maker by dispensing steam (for more details refer to the specific paragraph).	2nd function - Press to scroll the selection in the page upwards.
6		Cappuccino dispensing button - Page DOWN The button is used to select cappuccino dispensing.	2nd function - Press to scroll the selection in the page downwards.
7		Latte Macchiato dispensing button	
8		ON/OFF button	

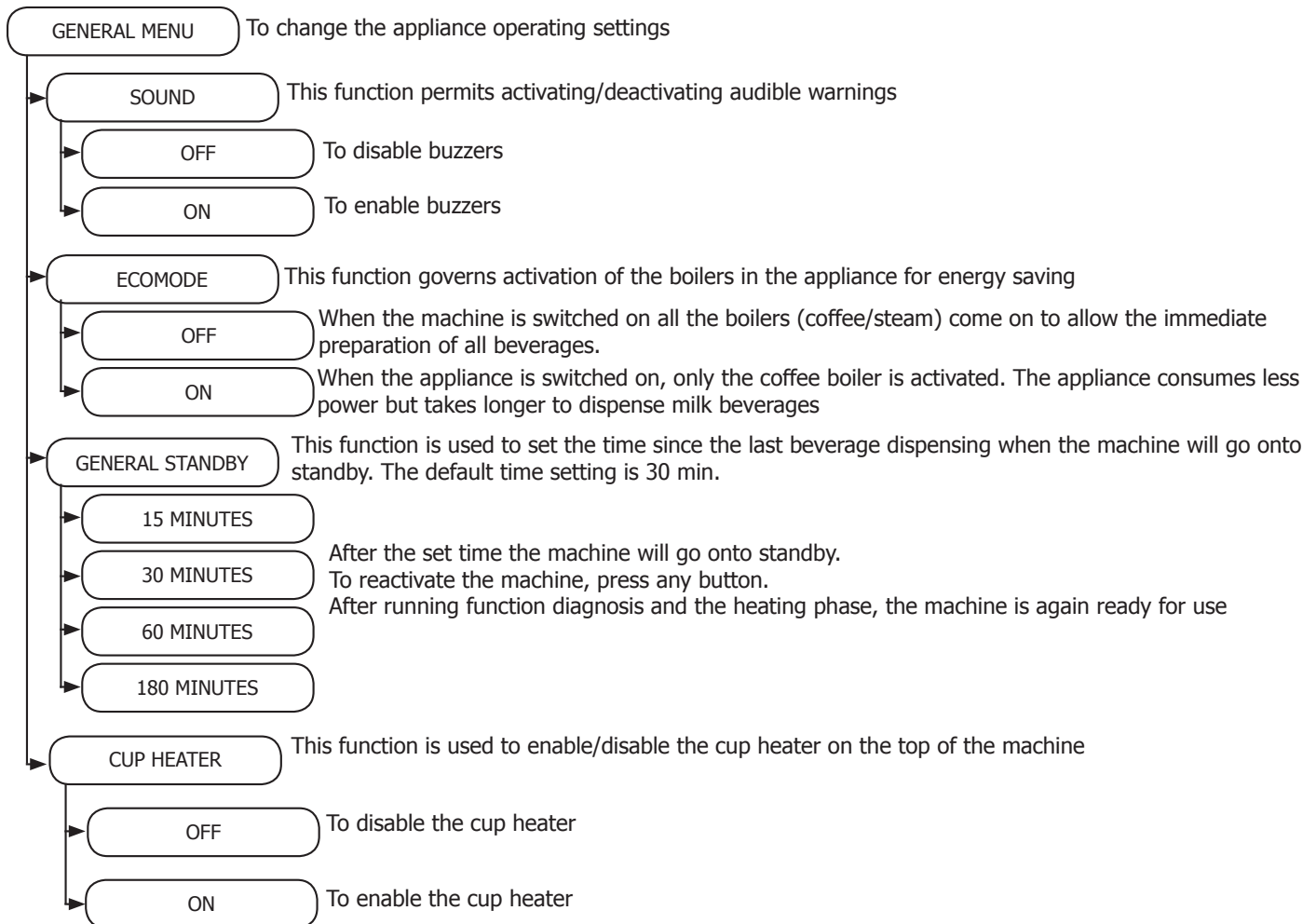
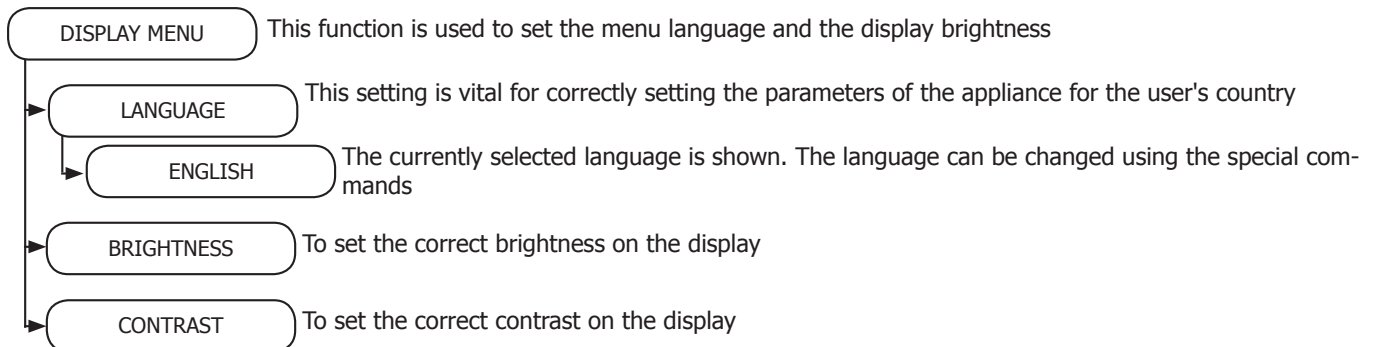
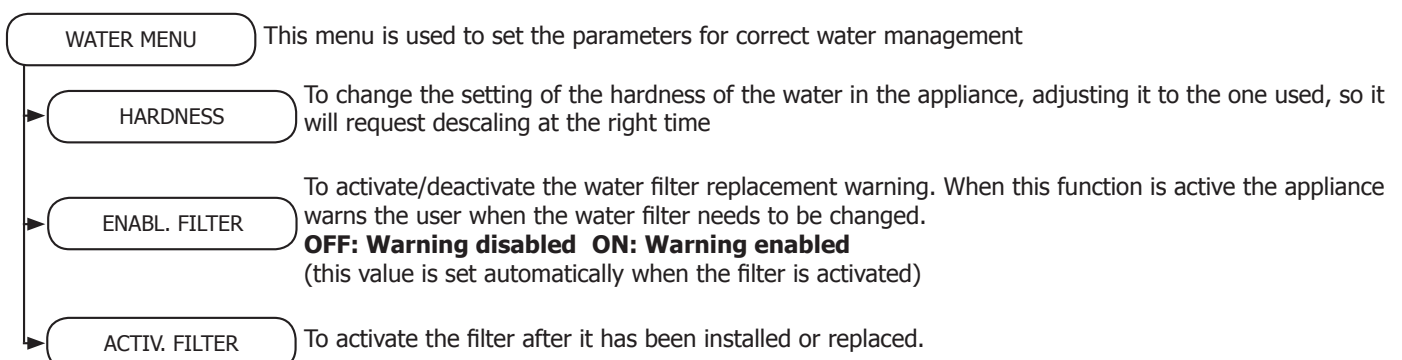
MACHINE MENU Used to customize the machine's operational settings**DISPLAY MENU****WATER MENU**







MAINTENANCE

MAINTENANCE	This function lets you set all the functions so that machine maintenance is managed better
UNIT CLEANING	This function is used to run the washing cycle for the Brewing Unit
DESCALING	This function is used to run the descaling cycle
CAPPUCCINO MAKER CLEANING	This function lets you run the washing cycle for the cappuccino maker used for making beverages containing milk

FACTORY SETTINGS

FACTORY SETTINGS	This function allows the factory values to be reset. Restoring the factory parameters deletes all the personal parameters set beforehand.
------------------	--

3.1.2. Machine indications

CHIUDERE LO SPORTELLLO LATERALE »!«	For the machine to become operative, the service hatch must be closed	AGGIUNGERE CAFFE' »!«	Fill the coffee hopper with coffee beans.
INSERIRE VASCA RACCOGLIGOCCE »!«	Insert the drip tray		The appliance requires a descaling cycle. If this message appears you may continue to use the machine but the operations may be compromised. Remember that any damage caused due to lack of de-scaling is not covered by the warranty.
INSERIRE CONTENITORE FONDI »!«	Insert the dreg drawer		The machine requires replacement of the "Intenza" water filter with a new one. Proceed with the replacement of the filter. The alarm is displayed only if the "Enable Filter" function is ON.
INSERIRE COPERCHIO CHICCI »!«	Close or correctly position the coffee bean hopper lid to enable dispensing of any beverage		The machine indicates that in a few cycles' time the dreg drawer will need emptying. This message allows you to carry on dispensing beverages.
RIEMPIRE SERBATOIO ACQUA »!«	Take out the tank and fill it with fresh drinking water		Remove the dreg drawer and empty out the dregs. Note: the dreg drawer must only be emptied with the machine switched on. If the drawer is emptied with the machine switched off the machine cannot register the emptying operation.
INSERIRE GRUPPO »!«	Insert the brewing unit in its correct location		An event has occurred that requires restarting the appliance. Note the code (E xx) shown at the bottom. Switch off the machine and switch it back on after 30 seconds. If the problem persists, contact the assistance center.
INSERIRE IL CAPPUCCINATORE »!«	An operation has been selected that requires the dispensing of milk. Insert the cappuccino maker in the machine as specified in the manual.		An operation has been selected that requires the dispensing of milk. Insert the valve in the cappuccino maker.
INSERIRE LA VALVOLA NEL CAPPUCCINATORE »!«	An operation has been selected that requires the dispensing of milk. Insert the valve in the cappuccino maker.		

3.2.1. Customer and programming menu in Royal Gran Crema

General Menu Royal Gran Crema

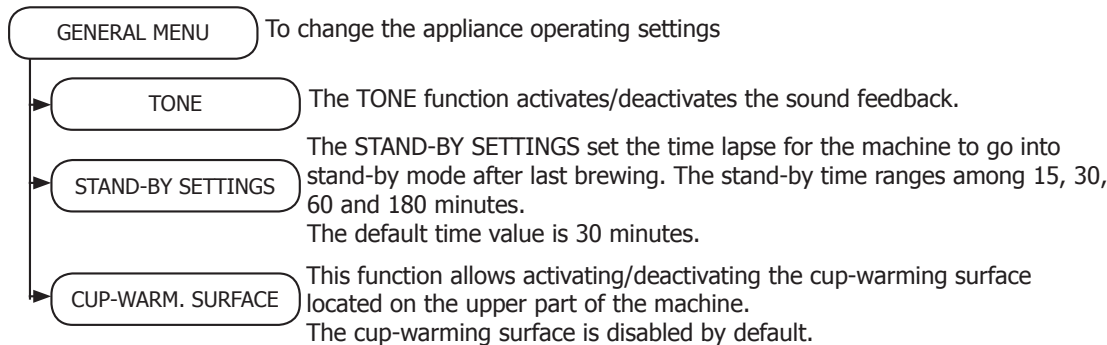

Display Menu Royal Gran Crema

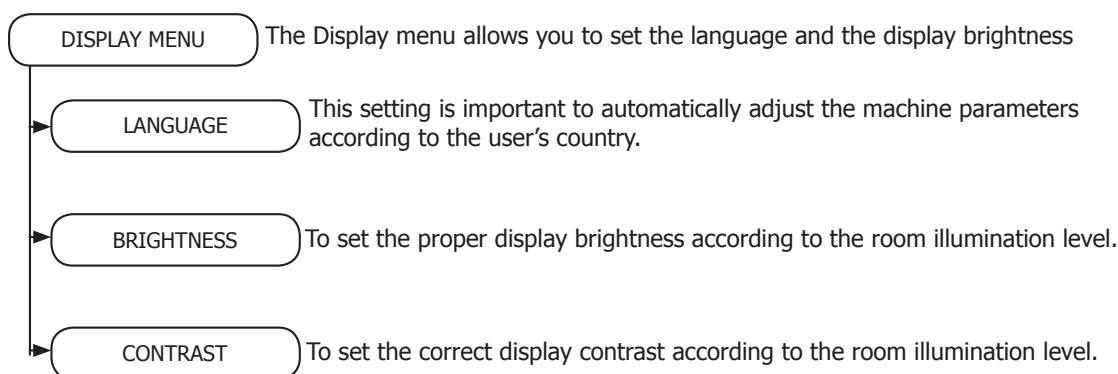

Water Menu Royal Gran Crema

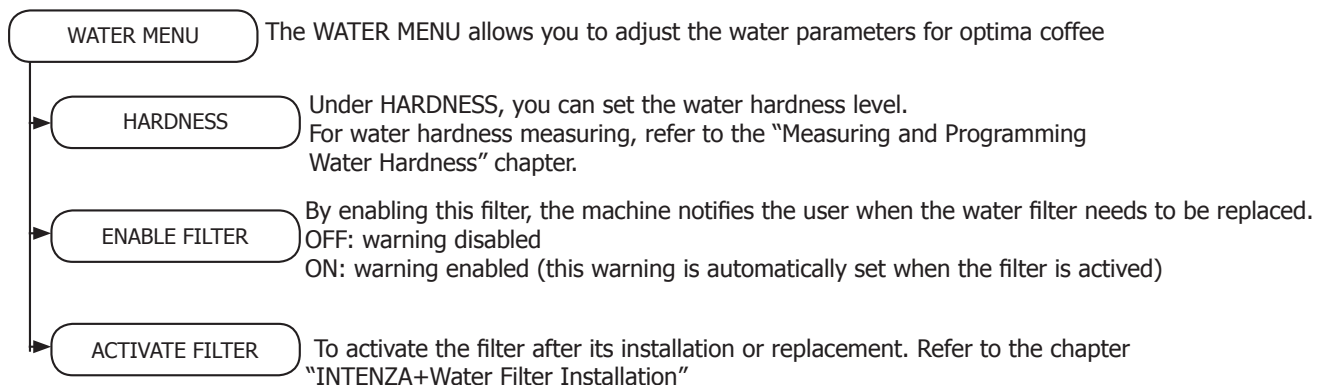

Maintenance Menu Royal Gran Crema

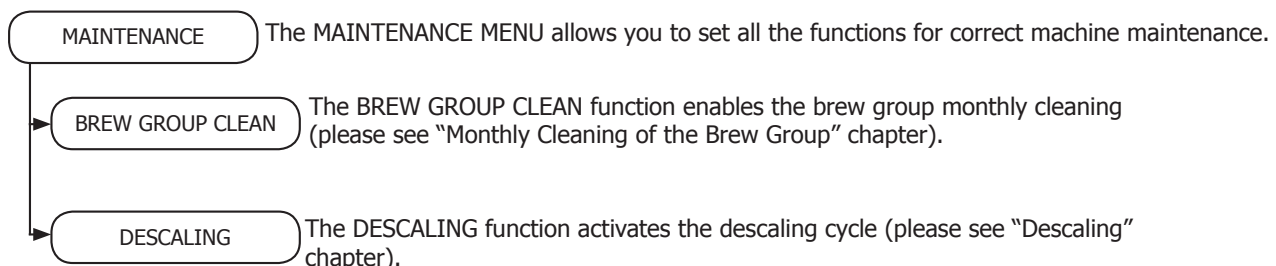

Factory Settings Royal Gran Crema

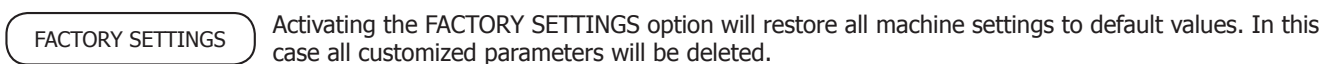

3.2.2. Machine indications in Royal Gran Crema



To restore the machine operation, close the service door.

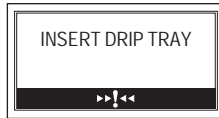

Insert the drip tray.



Insert the coffee grounds drawer.

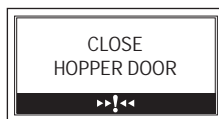

Close or correctly place the coffee bean hopper inner lid to be able to prepare any product.



Remove the tank and fill it with fresh drinking water.

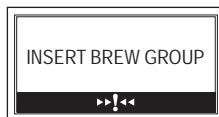

Insert the brew group into its seat.



Fill the coffee bean hopper with coffee beans.



The machine requests a descaling cycle. When this message is displayed, it is still possible to use the machine, but its correct operation might be affected. Damage caused by failure to descale the machine is not covered by warranty.



The machine requests the "INTENZA+" water filter to be replaced with a new one. Replace the filter as described in the "Replacing the "INTENZA+" Water Filter" chapter. The alarm is displayed only if the "ENABLE FILTER" function is set to ON ("Machine Programming chapter").



The machine reminds that after a few cycles it will be necessary to empty the coffee grounds drawer. This message does not prevent the machine from brewing some more products.



Remove the coffee grounds drawer and empty the coffee grounds into a suitable container.

Note: the coffee grounds drawer must be emptied only when the machine asks for it and with the machine turned on. If the drawer is emptied with the machine turned off, the machine will not record the emptying operation



Blinking red light. Machine in Stand-by. The stand-by settings can be changed ("Machine Programming" chapter).

Press the " " button.



An event has occurred which needs the machine to be restarted.

Take note of the code (E xx) shown at the bottom.

Turn off the machine, wait for 30 seconds and then turn it on again. If the problem persists, contact the service centre.



If this page is displayed after starting the machine, this means that the descaling cycle is needed.

Press the " " button to enter the descaling menu and refer to the relevant section.

Press the " " button to go on using the machine.

We remind you that damage caused by failure to descale the machine is not covered by warranty.

3.3. Operation, cleaning and maintenance

Operating the machine		
1	Fill water tank	
2	Fill the coffee bean hopper	
3	Switch on the appliance	
4	Press the button to start the appliance	
5	Select the desired language	Store
6	Heating	When the heating phase begins, wait for it to finish
7	Rinse	Carry out a rinse cycle for the internal circuits
8	Machine ready	The machine is ready to dispense beverages

CLEANING AND TECHNICAL SERVICING		
A	Empty the dreg drawer	When indicated
B	Empty the drip tray	As necessary (float indicator)
C	Clean the water tank	Weekly
D	Clean the coffee bean hopper	As necessary
E	Clean the casing	As necessary
F	Clean the brewing unit	Every time the coffee bean hopper is filled or weekly
	Lubricate the brewing unit	After 500 dispensing cycles
	Clean the unit housing	Weekly
H	Descaling	When indicated
I	Cleaning the cappuccino maker with detergent	Before redelivery

Descaling cycle frequency			
Hardness	Water hardness	Without water filter	With water filter
1	Soft (up to 7°dH)	240 litres (480,000 pulses)	480 litres (960,000 pulses)
2	Medium (7° - 14°dH)	120 litres (240,000 pulses)	240 litres (480,000 pulses)
3	Hard (15° - 21°dH)	60 litres (120,000 pulses)	120 litres (240,000 pulses)
4	Very hard (over 21°dH)	30 litres (60,000 pulses)	60 litres (120,000 pulses)

The default water hardness level is 4. Each litre of water corresponds to approximately 2,000 pulses



CHAPTER 4

OPERATING LOGIC

4.1. Water circuit

New Royal

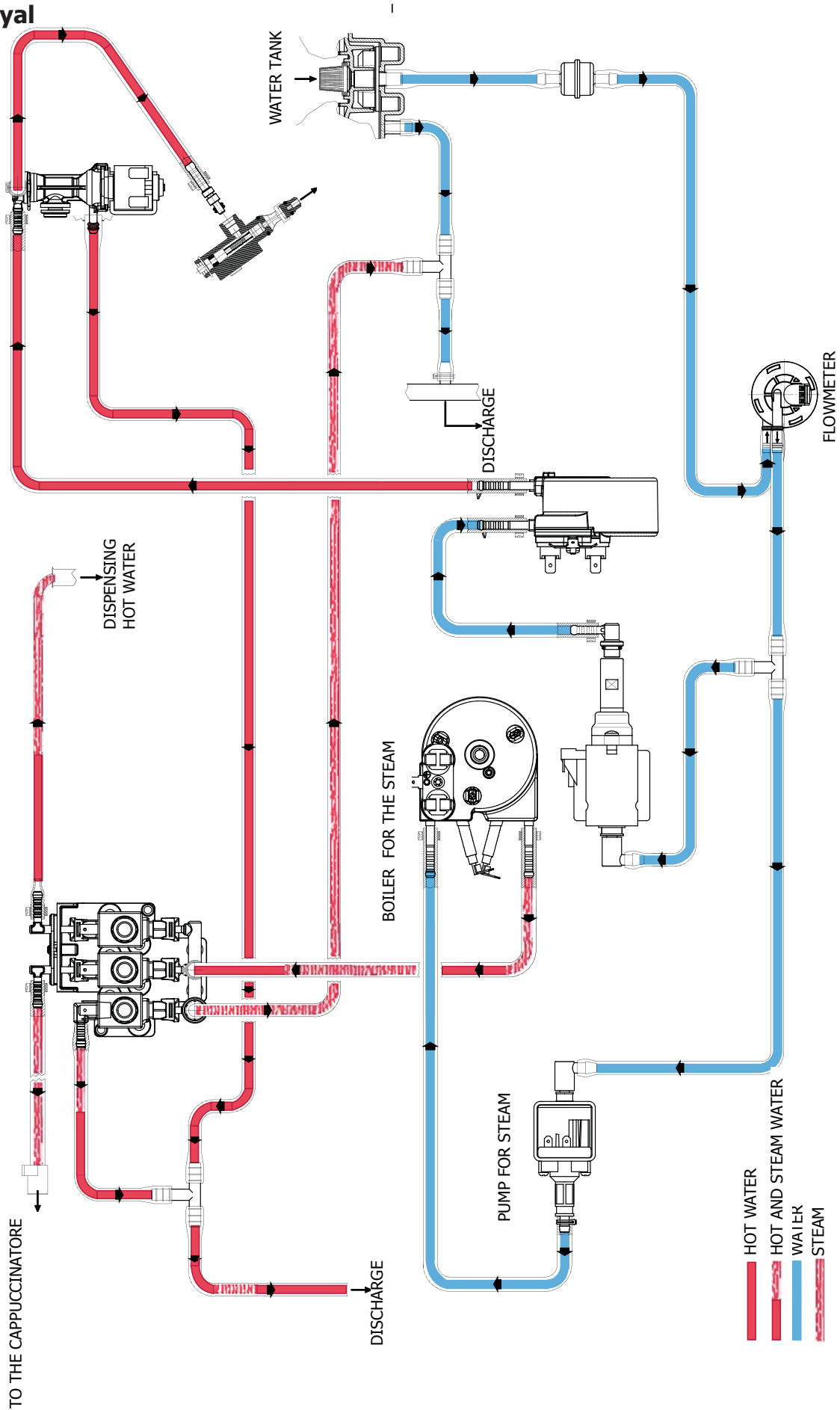

Royal Gran Crema

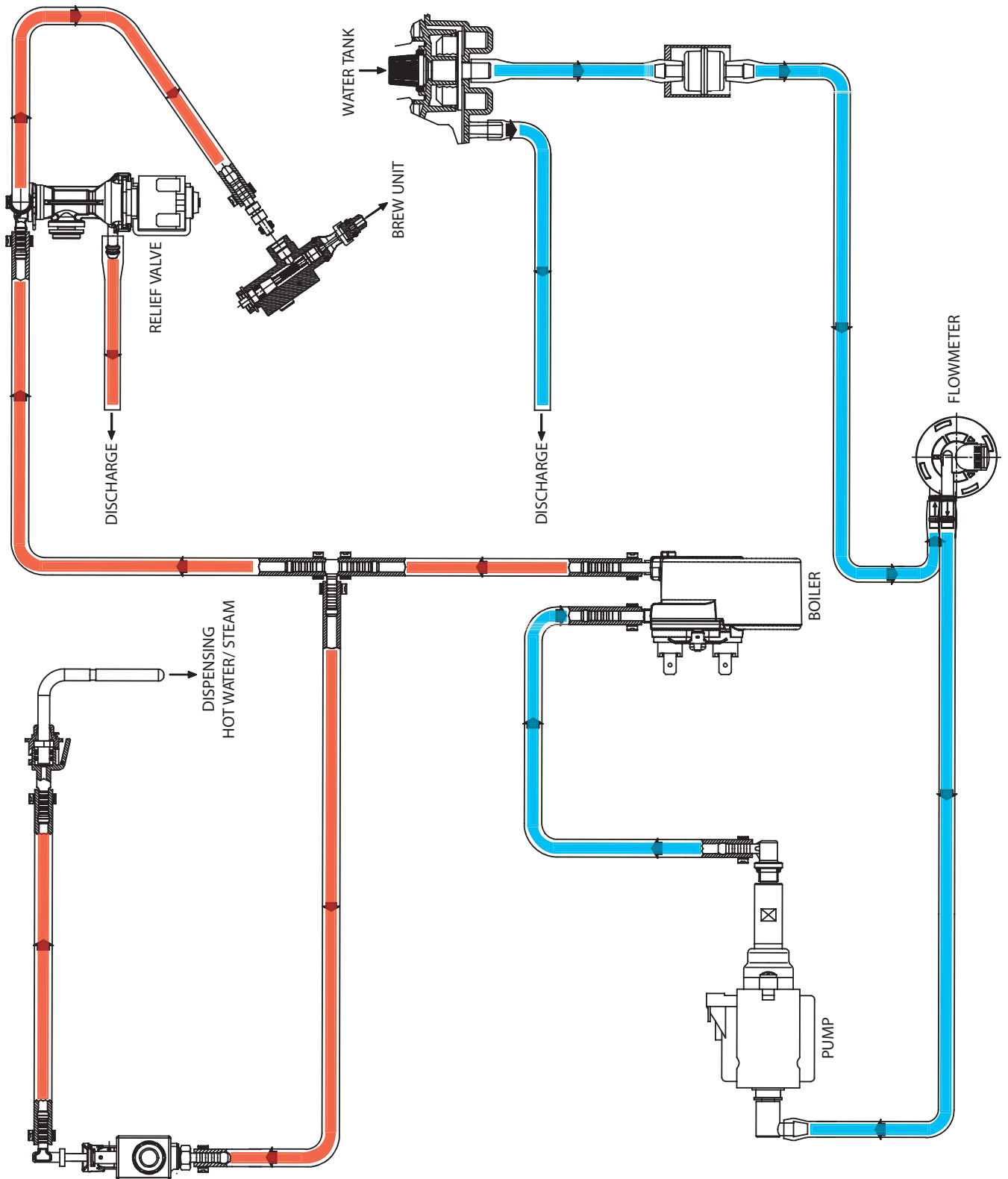

- WATER
- HOT WATER
- HOT AND STEAM WATER

4.2. Frother unit valve assembly

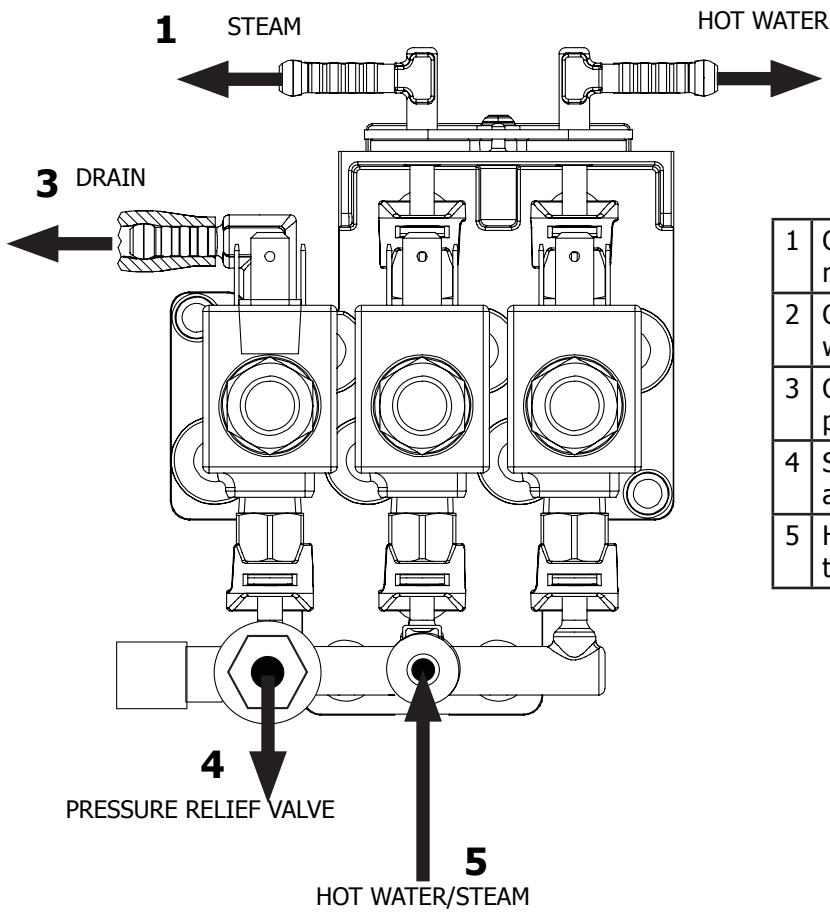

1	Outlet leading to the cappuccino maker for milk-based products
2	Outlet leading to the steam pipe but which dispenses hot water only
3	Outlet for reducing the internal pipe pressure after dispensing
4	Safety valve protecting the valve assembly
5	Hot water or steam inlet according to selected beverage

4.3. Cappuccino maker assembly

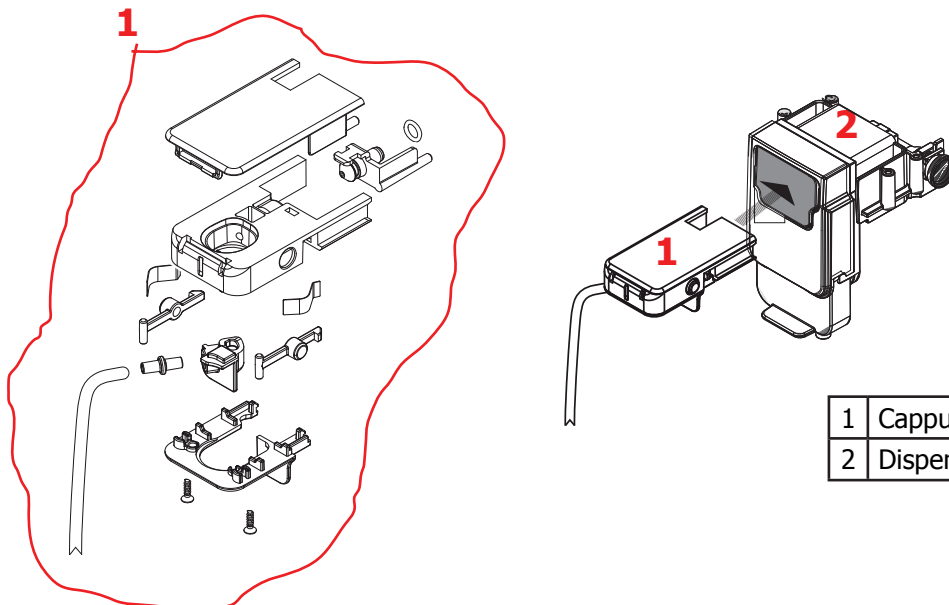

1	Cappuccino maker assembly
2	Dispenser assembly

4.4. Relief valve

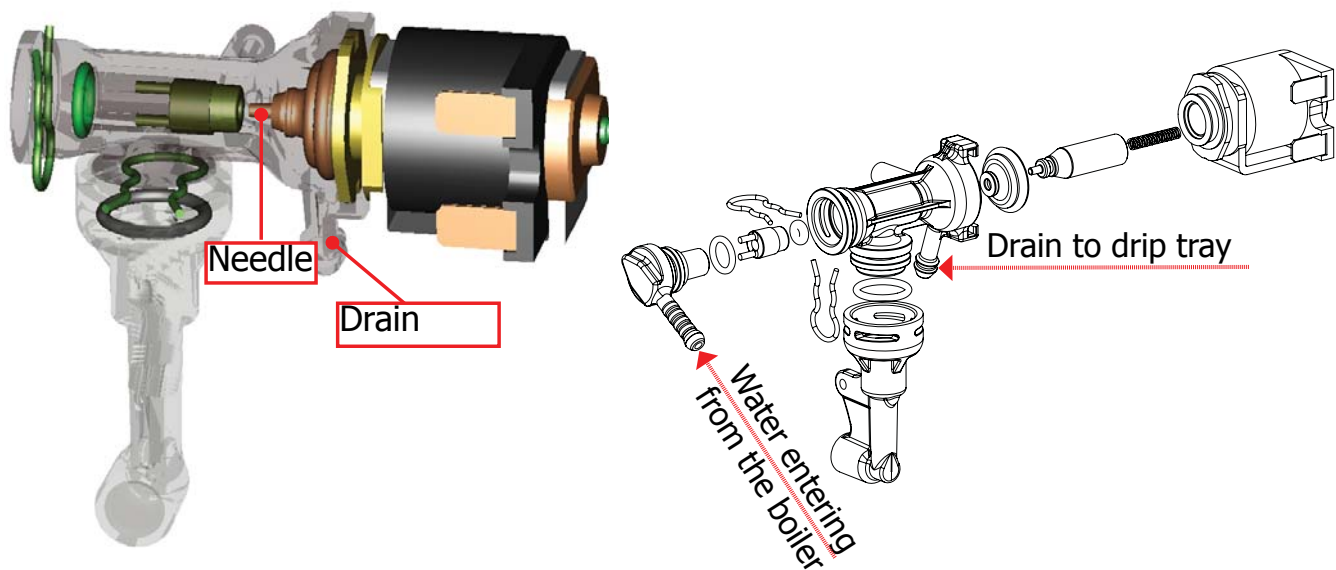

Functions:

Safety valve: functions as a safety valve by opening towards the drain in the event that the pressure rises above 16-19 bar

Filling the circuit: The solenoid valve opens (drain position) and the pump is activated, automatically refilling the circuit by expelling the air in the pipe

Unit discharge: before the unit descends it opens briefly, discharging the pressure created to prevent spraying and making the dregs drier

Coffee beverage: when a coffee beverage is selected, the pump is charged briefly during the grinding process and the valve assumes the drain position in order to fill the pipes with hot water.

4.5. Coffee cycle

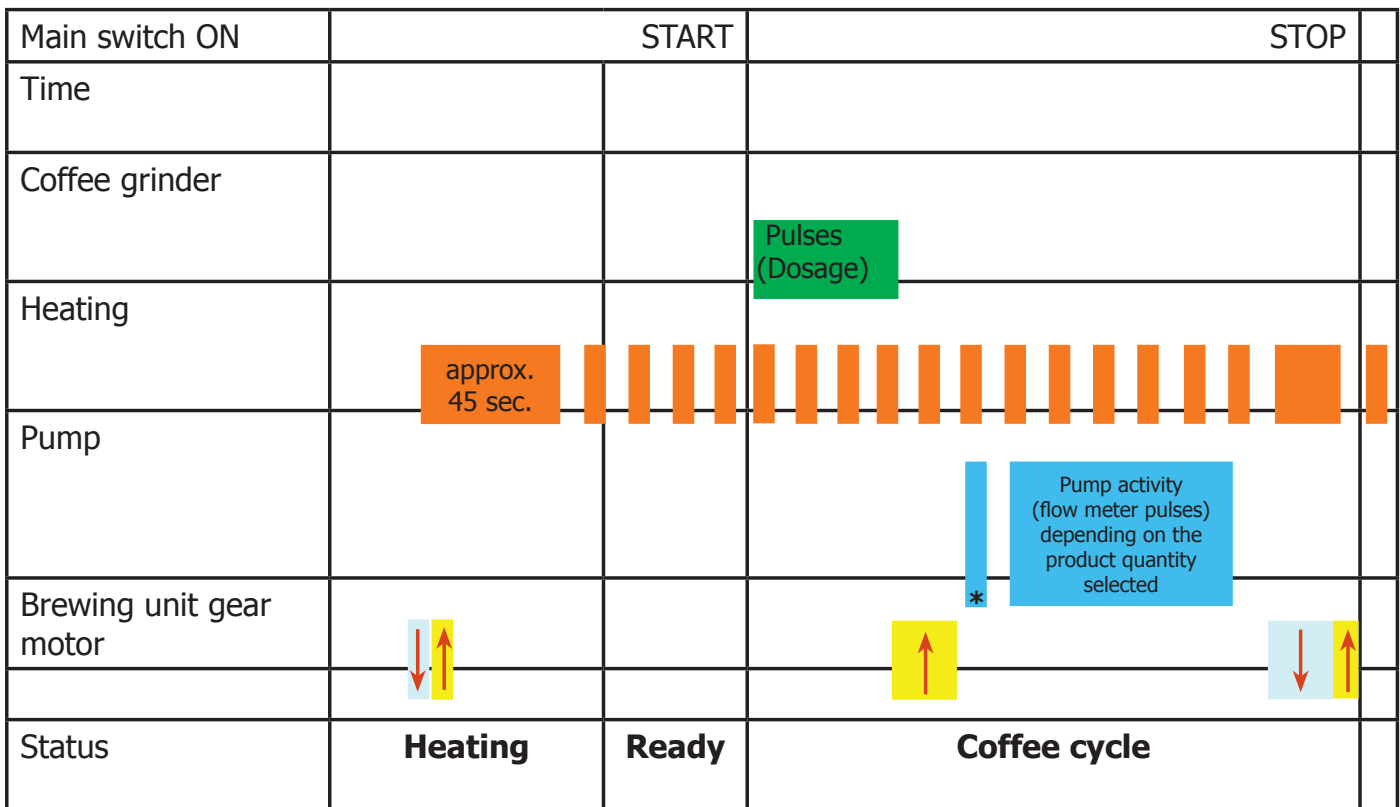

Notes: * Only with Pre-brewing



Single microswitch gear motor

Switching on

When the machine is switched on, the gear motor repositions itself as follows:

- It acts on microswitch 1 (see following chapter)
- The gear motor changes its rotation direction and moves upwards again by approx. 1-2 mm
- The boiler begins to heat the water for approx. 45 sec., at full power, in order to reach the optimal temperature. The temperature will then remain at a constant level.

Coffee cycle

1. The coffee grinder starts grinding (managed by the doser microswitch)
2. The doser opens
3. The gear motor (brewing unit) moves to the brewing position
4. Preliminary dispensing phase (short pump activity, short pause)
5. Product dispensing (the pump operation period is defined by the amount of product dispensed)
6. The gear motor moves to its home position (the dregs are expelled automatically)

4.6. Single microswitch

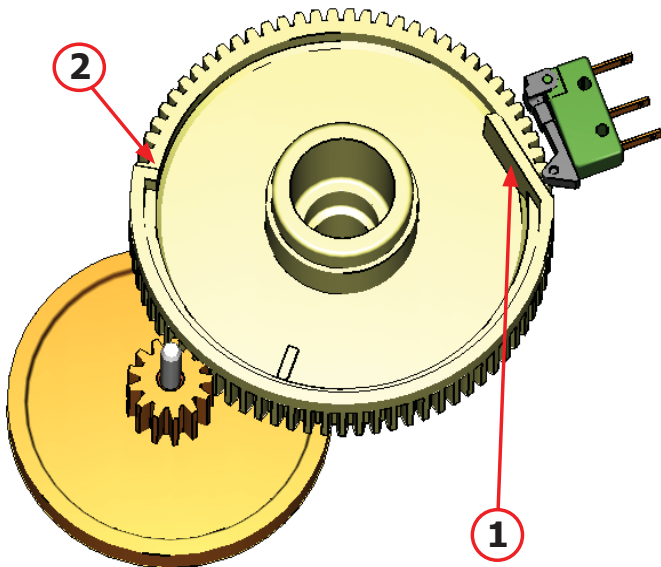

The gear motor is powered by a direct current motor that engages with the smaller double toothed wheel using a worm screw. The unit is mounted on the axle of the large gear wheel and when a coffee is requested, it moves from the standby position to the dispensing position, and then back to the standby position again.

- **Standby position: 1**

- **Dispensing position: 2**

4.7. Temperature sensor (adjustment)

Temp. (°C)	R nom (kΩ)	ΔR (+/- %)
20	61.465	8.6
50	17.599	5.9
75	7.214	4.1
80	6.121	3.7
85	5.213	3.4
90	4.459	3.1
100	3.3	2.5
125	1.653	3.9
150	0.893	5.1

An NTC is used as a temperature sensor; in the event of overheating this reduces boiler element power consumption.

The electronic system detects the current boiler temperature from the drop in voltage of the sensor and adjusts it accordingly.

Heating element values and corresponding temperatures: see table.

4.8. Water level detection (water tank)

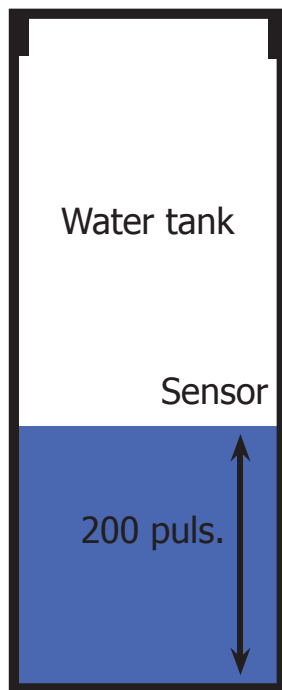

“Water low” message (water reserve)

Function:

The water level is monitored by a capacitive sensor, located one third of the way up the water tank wall.

If the electronics assembly detects, by means of the sensor, that the amount of water in the tank has dropped below the above mentioned level, a water reserve remains available for the dispensing process underway (this will cover 200 flow meter pulses).

The beverage dispensing process will then come to an end.

If a dispensing cycle ends after the sensor has been triggered (in the reserve) then the display “Water low” continues to be displayed during the following dispensing cycle.

4.9. Descaling request

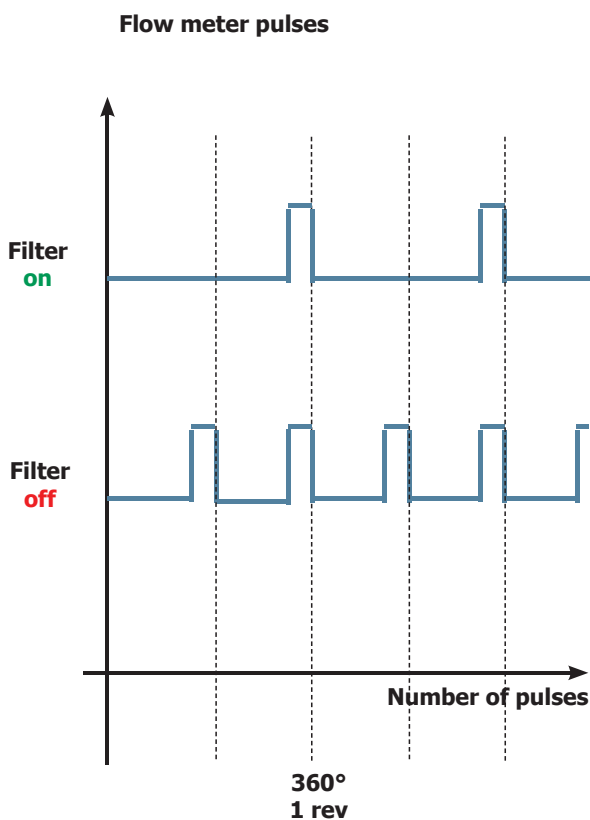

“Descaling” – message with water filter inserted

(appliances with display only)

The water hardness is set on the basis of the regional water hardness analysis (1, 2, 3, 4).

Filter off:

If the function is turned off the electronics assembly monitors the flow meter pulses, recording one pulse each turn.

Filter on:

If the function is turned on the electronics assembly monitors the flow meter pulses, recording one pulse every two turns.

“Change water filter” message

The electronics assembly uses the flow meter pulses to keep track of the amount of water which has flowed through; after the specified amount (set in accordance with the water hardness level), the “Replace filter” message appears.

4.10. Water filter

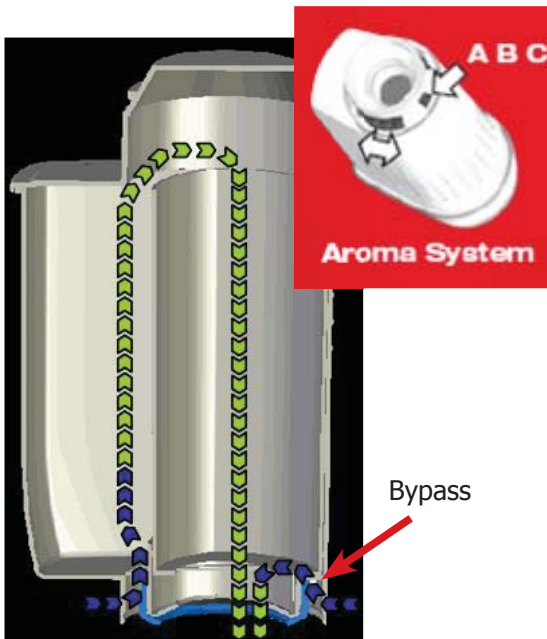

Water filter

Function:

- Reduced limescale deposits which take longer to form.
- Improved water quality.
- Improved taste due to the ideal water hardness

Life span / descaling performance:

- - 10 ° dH
- 60 litres
- 2 months

To achieve the best possible operating mode consistency over the total life span, the water is channelled using a 3-stage bypass (A, B, C) depending on the degree of hardness.

See small image.



CHAPTER 5

TROUBLESHOOTING

5.1.1. Test mode New Royal

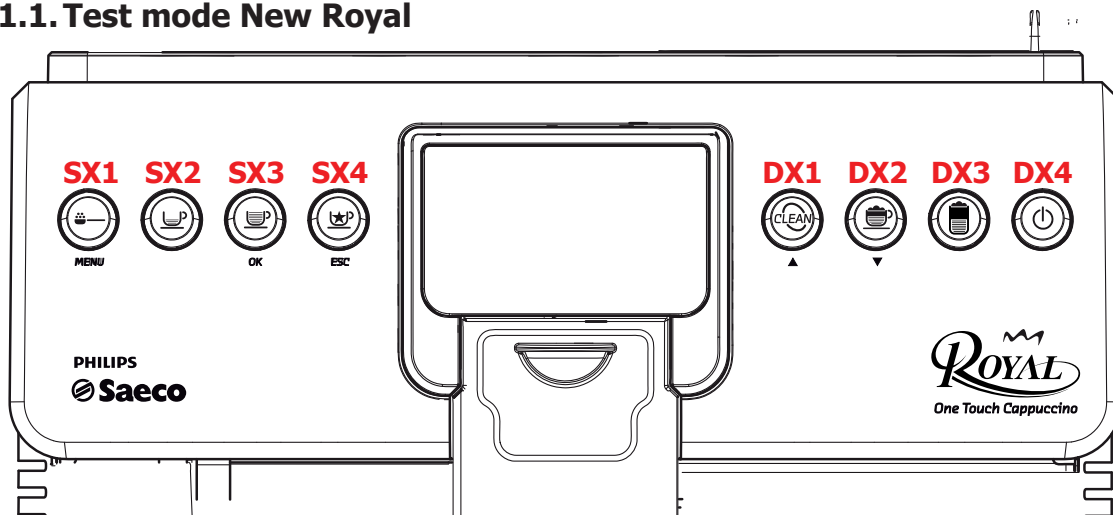

BUTTON	MAIN FUNCTION	SECONDARY FUNCTION
SX1	Select ground/pre-ground	Menu access (hold down)
SX2	Espresso	
SX3	Coffee	OK
SX4	Access to Special Menu	ESC
DX1	Clean cycle	Scroll menu up
DX2	Cappuccino	Scroll menu down
DX3	Latte macchiato	
DX4	Entry to Stand-By	

To enter Test Mode:

- Switch on the machine.
- Press the four function keys in the sequence indicated below (**SX3, SX2, SX4, SX1**) before the initialization bar is completed.

TITLE			
SX1	SX2	SX3	
INFO1	INFO2	INFO3	INFO4
INFO5	INFO6	INFO7	
	DX2	DX3	DX4

Entry into Test Mode results in a screen divided into sections, as illustrated in the diagram below

The sectors highlighted in yellow on the following screens represent the various loads that can be activated by pressing the keys indicated in each sector.

This load is deactivated by pressing the same key once more.

The sectors highlighted in green provide information on the sensor status.

Other conditions in which a load can be automatically deactivated are:

- If a work cycle is defined and ends (e.g., coffee grinder or brewing unit).
- A time-out is reached (e.g.: 5 sec for the boiler test).

The symbols ▼ ▲ can be activated with keys SX4 and DX1 and are used to navigate the Test mode.

Description of each page

1 Software

1 Software			
DF:64	ER:8	Debug	▲
B2C	B2B	B2B RI	MV: xx
f: xx Hz	*	xx.yy.zz	
▼	Swiss	Pow Off	ESC

SECTOR	TYPE	DESCRIPTION
DF	FUNCTION	Provides information on the memory status. Must be 64
ER	FUNCTION	Provides information on the memory status. Must be 8
Debug	FUNCTION	If selected, enables a debug window in user mode
Swiss	FUNCTION	The Swiss function is used to enable or disable the ECO-MODE default setting. If Swiss is enabled, the default for the Eco-Mode is "ON", if Swiss is disabled the default for the Eco-Mode is "OFF". The water circuit emptying function restores the ECOMODE value to the default value. As stated above, the default value depends on the Swiss setting.
Pow Off	FUNCTION	Indicates whether the machine will go to Stand-By mode when powered up - main electro-mechanical switch (I/O) on, if this occurs the words "Pow Off" are highlighted. If it is disabled, the machine will not go to Stand-By mode straight after Power On.
ESC	FUNCTION	If pressed, it exits the Test mode.
B2C	INFO	If activated, it indicates that the machine version is B2C.
B2B	INFO	If activated, it indicates that the machine version is B2B.
B2B RI	INFO	If activated, it indicates that the machine version is B2B with mains water.
MV: xx	INFO	Indicates the version of the EEPROM Memory
f	INFO	Indicates the mains frequency. It has the following values: 50 Hz 60 Hz ERR if the frequency cannot be detected.
xx.yy.zz	INFO	Indicates the version of the loaded software.

Press DX1 to move on to the next screen

2 Brew Unit

2 Brew Unit			
Work	Home	Stop	▲
H/W	m Door	m Dreg	m BU
xx	m Tray	mA: xxxx	
▼	Dreg+	Dreg-	*

SECTOR	TYPE	DESCRIPTION
Work	FUNCTION	If activated, it causes the gear motor to move the unit into the Work position
Home	FUNCTION	If activated, it causes the gear motor to move the unit into the Home position
Stop	FUNCTION	If activated, it stops the gear motor
Dreg+	FUNCTION	If activated it increases the maximum value of the dregs set before the alarm is activated
Dreg-	FUNCTION	If activated it decreases the maximum value of the dregs set before the alarm is activated
H/W	INFO	If activated it indicates that the Home/Work position microswitch has been pressed
m Door	INFO	If activated it indicates that the side hatch microswitch has been pressed
m Dreg	INFO	If activated it indicates that the magnetic reed sensor for the dreg drawer presence is active container present
m BU	INFO	If activated it indicates that the unit presence microswitch has been pressed
xx	INFO	Indicates the current value set for the maximum quantity of dregs
m Tray	INFO	If activated it indicates that the magnetic reed sensor for the drip tray presence is active drip tray present
mA	INFO	Indicates the maximum unit current value as an average in one sec.

Press DX1 to move on to the next screen

3 Water Circuit

3 Water Circuit			
EV steam	EVwater	EVdisch.	▲
m Capp	m Milk	m Tank	*
T1 xx	T2 xx	p/s: xx	
▼	EVcoffee	Pump 1	Pump 2

SECTOR	TYPE	DESCRIPTION
EVsteam	FUNCTION	If activated it switches on the 24VDC solenoid valve in the steam circuit
EVwater	FUNCTION	If activated it switches on the 24VDC solenoid valve in the hot water circuit
EVdisch.	FUNCTION	If activated it switches on the 24VDC solenoid valve in the steam circuit discharge
EVcoffee	FUNCTION	If activated it switches on the 230VAC solenoid valve in the electro-pilot
Pump 1	FUNCTION	If activated it switches on pump 1 in the coffee circuit
Pump 2	FUNCTION	If activated it switches on pump 2 in the water/steam circuit

SECTOR	TYPE	DESCRIPTION
m Capp	INFO	Indicates the status of the presence of the cappuccino maker unit if it is inserted it is on
m Milk	INFO	Indicates the status of the presence of the milk valve inside the cappuccino maker if it is inserted it is on
m Tank	INFO	If activated it indicates that the water sensor in the tank is active water present at least to the sensor level
T1 xx	INFO	indicates the temperature of the coffee boiler in °C
T2 xx	INFO	indicates the temperature of the water/steam boiler in °C
p/s: xx	INFO	indicates the water flow rate in the water circuit, expressed in flow meter pulses per second

Press DX1 to move on to the next screen

4 Heaters & Grinder

4 Heaters & Grinder			
Heater 1	Heater 2	St.Out.	▲
T1 xx	T2 xx	NoBean	T.O.
m Bean	m Dose	Grinder Block	
▼	Grinder	EVdose	CupHeat

SECTOR	TYPE	DESCRIPTION
Heater 1	FUNCTION	If activated, runs the coffee boiler for T.O. (8 seconds). The boiler comes on only if the coffee boiler temperature is less than 130°C
Heater 2	FUNCTION	If activated, runs the coffee boiler for T.O. (8 seconds). The boiler comes on only if the water/steam boiler temperature is less than 130°C
St.Out.	FUNCTION	If selected, it activates the Steam-Out function
Grinder	FUNCTION	If activated, it activates the coffee grinder. The coffee grinder remains on until the activation button is no longer pressed, or the coffee low warning is given or the doser chamber is filled, i.e. the "m Dose" microswitch is pressed. The coffee grinder will not come on if the "m Bean" sensor is not enabled (bean lid closed)
EVdose	FUNCTION	Activates the doser solenoid valve for 0.5 sec
CupHeat	FUNCTION	Activates the cup heater plate
T1 xx	INFO	indicates the temperature of the coffee boiler in °C
T2 xx	INFO	indicates the temperature of the water/steam boiler in °C
NoBean	INFO	If activated, it indicates that there is no coffee
T.O.	INFO	Displays the 8 second countdown prior to boiler activation
m Bean	INFO	If activated it indicates that the bean hatch is closed
m Dose	INFO	If activated, it indicates that the doser microswitch is pressed doser chamber full
Grinder Block	INFO	If activated, it indicates that the coffee grinder is blocked for safety reasons

5.1.2. Diagnostics mode New Royal

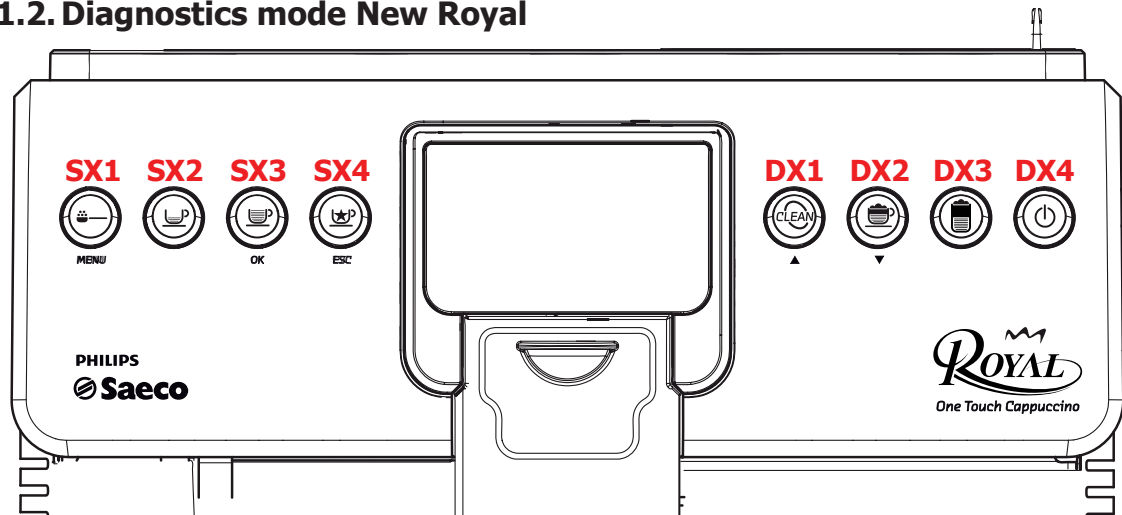

To enter Diagnostics mode:

- Switch on the machine
- Press the four function keys in the sequence indicated below (**SX2, SX4, SX1, SX3**) before the initialization bar is completed

Description of menus in diagnosis mode

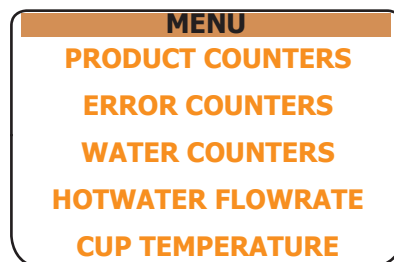

1. Product counters

- Espresso
- Coffee
- Long coffee
- American Coffee
- Hot water
- Cappuccino
- Latte macchiato
- Hot milk

2. Error counters

2.1. Error log

- Error code
- Error index
- Error text

2.2. Errors reset

3. Water counters

3.1. Descaling cycle

- Since last
- Since second last
- Since third last
- Number of execution

3.2. Brewing unit cleaning

- Number of execution
- Since last

3.3. Since production

3.4. Water filter

- Since last reset
- Number of reset

4. Hotwater flowrate

- 100 ÷ 150

5. Cup temperature

- 75 ÷ 85

Press buttons **DX2** or **DX1** to move the cursor onto the desired beverage and press **SX3** to enter the sub-menu

1. PRODUCT COUNTERS

• ESPRESSO (default 0)	• dispensing no.
• COFFEE (default 0)	• dispensing no.
• LONG COFFEE (default 0)	• dispensing no.
• AMERICAN COFFEE (default 0)	
• HOT WATER (default 0)	• dispensing no.
• CAPPUCCINO (default 0)	• dispensing no.
• LATTE MACCHIATO (default 0)	• dispensing no.
• HOT MILK (default 0)	• dispensing no.

2. ERROR COUNTERS

• ERRORS LOG (default 0)	• ERROR CODE (default 0)	ERROR CODE - the code representing the type of error that has occurred (see Tab. 5.3 Error messages)
	• ERROR INDEX (default 0)	NUMERICAL POSITION - represents the numerical position of the error in the internal list for a max no. of 20
	• ERROR TEXT (default 0)	ERROR DESCRIPTION - a text description of the type of error that has occurred

• ERRORS RESET	All the errors are reset
----------------	--------------------------

3. WATER COUNTERS

• DESCALING CYCLES	• SINCE LAST (default 0)	Represents the consumption of water since the last descaling cycle
	• SINCE SECOND LAST (default 0)	As above but for the penultimate descaling cycle
	• SINCE THIRD LAST (default 0)	As above but for the third last descaling cycle
	• NUMBER OF EXECUTION (default 0)	total no. of descaling cycles performed
• BREWING UNIT CLEANING	• NUMBER OF EXECUTION (default 0)	Represents the consumption of water since the last unit cleaning cycle. When performed it goes back to 0.
	• SINCE LAST (default 0)	Represents the number of unit cleaning cycles carried out on the C.A.
• WATER FILTER	• SINCE LAST RESET (default 0)	Represents the consumption of water since the last filter activation cycle. When performed it goes back to 0
	• NUMBER OF RESET (default 0)	total no. of filter activation cycles performed.

• WATER SINCE PRODUCT	Total consumption of water in litres (default 0)
-----------------------	--

6. HOTWATER FLOWRATE 100 to 150 (default 120)

7. CUP TEMPERATURE 75 to 85 (default 78)

5.2. Test mode Royal Gran Crema

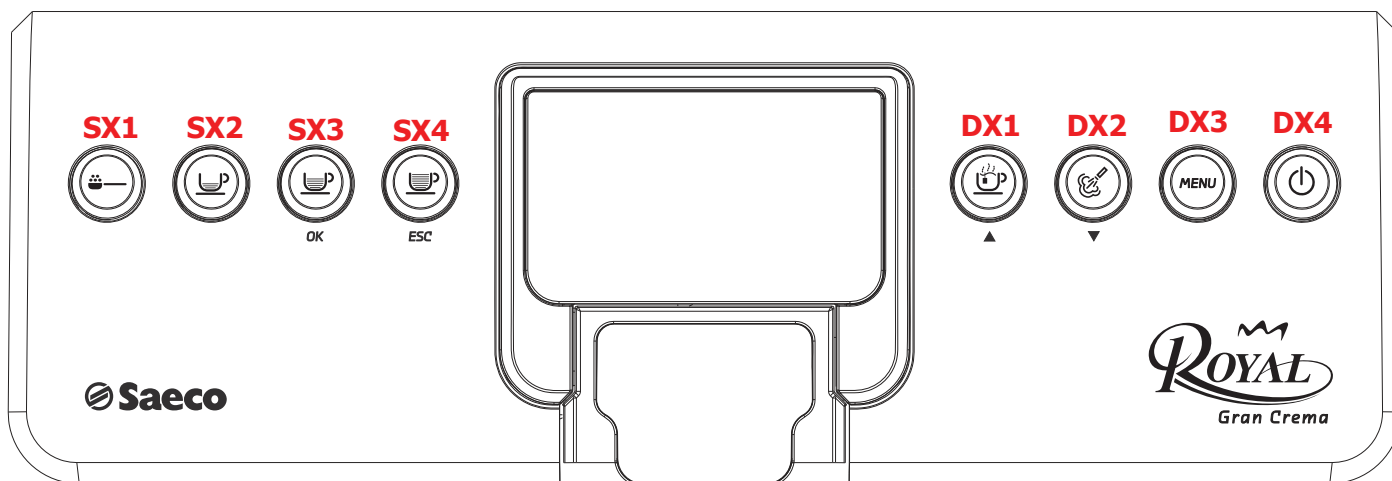

To enter Test Mode:

- Switch on the machine.
- Press the four function keys in the sequence indicated below (**SX3, SX2, SX4, SX1**) before the initialization bar is completed.

Entry into Test Mode results in a screen divided into sections, as illustrated in the diagram below

TITLE			
SX1	SX2	SX3	▲
INFO1	INFO2	INFO3	INFO4
INFO5	INFO6	INFO7	
▼	DX2	DX3	DX4

The sectors highlighted in yellow on the following screens represent the various loads that can be activated by pressing the keys indicated in each sector.

This load is deactivated by pressing the same key once more.

The sectors highlighted in green provide information on the sensor status.

Other conditions in which a load can be automatically deactivated are:

- If a work cycle is defined and ends (e.g., coffee grinder or brewing unit).
- A time-out is reached (e.g.: 5 sec for the boiler test).

The symbols ▼ ▲ can be activated with keys SX4 and DX1 and are used to navigate the Test mode.

Description of each page

1 Software

1 Firnware & MCU Config			
CW.884B3C53	Fv.01.02.01	▲	
AG.88A83DE4	EM. 1	EV. 15	
f: xx Hz	230 V	Boot.01.04.00	
▼	Debug	Pow Off	ESC

SECTOR	TYPE	DESCRIPTION
CW	INFO	Provides information on the memory status. (internal information)
Fv	INFO	Firmware version.
AG	INFO	Provides information on the memory status. (internal information)
EM	INFO	Provides information on the memory status. (internal information)
EV	INFO	Provides information on the memory status. (internal information)
f	INFO	Indicates the mains frequency. It has the following values: 50 Hz 60 Hz ERR if the frequency cannot be detected.
- - - V	INFO	Tension board
Boot	INFO	Provides information on the memory status. (internal information)
Debug	FUNCTION	Enable / Disable debug messages during the normal functioning of the machine, but currently is not functional if activated / deactivated by the display.
Pow Off	FUNCTION	Indicates whether the machine will go to Stand-By mode when powered up - main electro-mechanical switch (I/O) on, if this occurs the words "Pow Off" are highlighted. If it is disabled, the machine will not go to Stand-By mode straight after Power On.
ESC	FUNCTION	If pressed, it exits the Test mode.

Press DX1 to move on to the next screen

2 Brew Unit

2 Brew Unit			
Work	Home	Stop	▲
m H/W	m Door	m Dreg	m BU
xx	m Tray	mA: xxxx	
▼	Dreg+	Dreg-	-

SECTOR	TYPE	DESCRIPTION
Work	FUNCTION	If activated, it causes the gear motor to move the unit into the Work position
Home	FUNCTION	If activated, it causes the gear motor to move the unit into the Home position
Stop	FUNCTION	If activated, it stops the gear motor
Dreg+	FUNCTION	If activated it increases the maximum value of the dregs set before the alarm is activated
Dreg-	FUNCTION	If activated it decreases the maximum value of the dregs set before the alarm is activated
H/W	INFO	If activated it indicates that the Home/Work position microswitch has been pressed
m Door	INFO	If activated it indicates that the side hatch microswitch has been pressed
m Dreg	INFO	If activated it indicates that the magnetic reed sensor for the dreg drawer presence is active container present
m BU	INFO	If activated it indicates that the unit presence microswitch has been pressed
xx	INFO	Indicates the current value set for the maximum quantity of dregs
m Tray	INFO	If activated it indicates that the magnetic reed sensor for the drip tray presence is active drip tray present
mA	INFO	Indicates the maximum unit current value as an average in one sec.

3 Hydraulic Circuit

3 Hydraulic Circuit			
EV W/S	-	EV Dsg	▲
T1 25	-	m Tank	-
-	-	p/s: xx	
▼	EV AC	Pump 1	-

SECTOR	TYPE	DESCRIPTION
EVsteam	FUNCTION	If activated it switches on the 24VDC solenoid valve in the steam circuit
EVdisch.	FUNCTION	If activated it switches on the 24VDC solenoid valve in the steam circuit discharge
EV AC	FUNCTION	If activated it switches on the 230VAC solenoid valve in the electro-pilot
Pump 1	FUNCTION	If activated it switches on pump 1 in the coffee circuit
m Tank	INFO	If activated it indicates that the water sensor in the tank is active water present at least to the sensor level
T1 xx	INFO	indicates the temperature of the coffee boiler in °C
p/s: xx	INFO	Indicates instant by instant the water flow in the turbine, expressed in pulses per second. When powered Pump1 (pump coffee) and activated the solenoid valve 230V (EVcoffee) the value should not be less than 12 p / sec.

Press DX1 to move on to the next screen

4 Heaters & Grinder

4 Heaters & Grinder			
Heater 1	-	St.Out.	▲
T1 xx	-	NoBean	T.O.
m Bean	m Dose	Grinder Block	
▼	Grinder	EVdose	CupHeat

SECTOR	TYPE	DESCRIPTION
Heater 1	FUNCTION	If activated, runs for T.O. (8 seconds). The boiler comes on only if the coffee boiler temperature is less than 130°C
St.Out.	FUNCTION	If selected, it activates the Steam-Out function
Grinder	FUNCTION	If activated, it activates the coffee grinder. The coffee grinder remains on until the activation button is no longer pressed, or the coffee low warning is given or the doser chamber is filled, i.e. the "m Dose" microswitch is pressed. The coffee grinder will not come on if the "m Bean" sensor is not enabled (bean lid closed)
EVdose	FUNCTION	Activates the doser solenoid valve for 0.5 sec
CupHeat	FUNCTION	Activates the cup heater plate
T1 xx	INFO	indicates the temperature of the coffee boiler in °C
NoBean	INFO	If activated, it indicates that there is no coffee
T.O.	INFO	Displays the 8 second countdown prior to boiler activation
m Bean	INFO	If activated it indicates that the bean hatch is closed
m Dose	INFO	If activated, it indicates that the doser microswitch is pressed doser chamber full
Grinder Block	INFO	If activated, it indicates that the coffee grinder is blocked for safety reasons

5.3. Error messages

Code	Brief description	Description
01	Coffee grinder blocked	The coffee grinder is blocked (grinder blades jammed or sensor not reading properly)
03	Brewing unit blocked in 'work' position	Descent time-out exceeded
04	Brewing unit blocked in 'home' position	Ascent time-out exceeded
05	Water circuit blocked	No water in flow meter or flow meter not turning (jammed)
06	Frother unit solenoid valve	Frother unit solenoid valve short-circuit
07	Doser microswitch blocked	Doser microswitch short-circuit
10	Coffee boiler short-circuit	Coffee boiler temperature sensor short-circuit
11	Coffee boiler in open circuit	Coffee boiler temperature sensor in open circuit
12	Steam boiler short-circuit	Steam boiler temperature sensor short-circuit
13	Steam boiler in open circuit	Steam boiler temperature sensor in open circuit
14	Misc. temperature errors (coffee boiler)	Coffee boiler temperatures out of control
15	Misc. temperature errors (steam boiler)	Steam boiler temperatures out of control
16	Brewing unit short-circuit	Brewing unit microswitch short-circuit
17	Not used	
18	Not used	
19	No zero crossing	No zero crossing on card, could be caused by power board
20	Not used	



CHAPTER 6

STANDARD CHECKS

6.1. Repair schedule

	Action
1	Visual inspection (transport damage)
2	Machine data check (rating plate)
3	Operational check / problem analysis
4	Opening machine
5	Visual inspection
6	Operational tests
7	Repairing the faults encountered
8	Checking any modifications (view Symptom Cure, new software, etc.)
9	Service activities in accordance with the operating schedule
10	Internal cleaning
11	Operational test while the appliance is open
12	Assembly
13	Final inspection test
14	Draining the circuit (in winter)
15	External cleaning
16	Lubricating the brewing unit with suitable grease
17	Insulation test HG 701 (dielectric)
18	Documentation

6.2. Service schedule

S	Replacement
ES	Visual inspection
D	Descaling
CF	Operative check

P	Cleaning
TR	Noise test
R	Adjustment

Component	Action	Support/tool
Water filter	P/S/CF	
Water tank lip seal	S/CF	
Boiler pin O-ring	S/CF	
Brewing unit	ES/P/CF	Grease solvent / Grease
Hoses, attachments and Oetiker clamps	ES/CF	
Coffee circuit pump	ES/TR/CF	
Hot water/steam circuit pump	ES/TR/CF	
Gear motor	ES/TR/CF	
Coffee grinder	P/R/CF	Vacuum cleaner / brush
Water circuit	D/CF	Saeco descaler
Frothing valve assembly	ES/S/CF	
Multi-way valve (solenoid pilot)	ES/S/CF	

6.3. Final test

Test	Procedure	Support/tool	Standard	Tolerance
Espresso	2-3 Espressos for adjustment purposes	Measuring scoop	Same amount	15%
Coffee	2-3 Coffees for adjustment purposes	Measuring scoop	Same amount	15%
Noise			Standard	
Amount of cream	Blow into the cup until the cream separates		The cream should come together again to form a complete layer	
Cream colour			Hazel brown	
Temperature	Reading taken while dispensing	Thermometer	84 °C	± 4 °C
Grinding level	Check the grain size of the ground coffee			
Hot water	Dispense water			
Steam	Dispense steam			
Dreg drawer missing indication	Remove the dreg drawer		Dreg drawer missing indication	
Low bean level indication	Start brewing a coffee while the coffee bean hopper is empty		Low bean level indication	



CHAPTER 7

DISASSEMBLY

7.1. Outer elements



Loosen the screws as illustrated and remove the grinding adjustment lever handle.

Remove the lid and the water tank, coffee bean and ground coffee container lid, dreg drawer, drip tray, brewing unit, coffee unit support plate, coffee dispenser.



Loosen the screw as illustrated and remove the grinding adjustment lever.



Loosen the screws as illustrated.

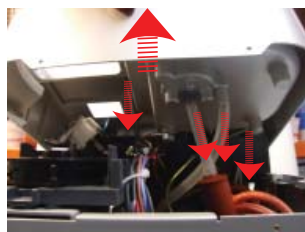

Lift the upper lid and disconnect the electrical and water circuit connections which prevent it from being removed.



Slide out the pin as illustrated and remove the hatch.

7.2. Coffee grinder

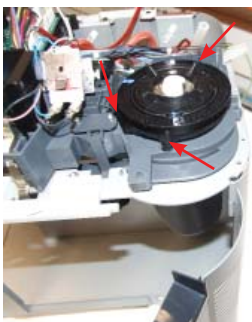

Vibration damper.

Slide out the coffee grinder from the vibration dampers as illustrated.



Disconnect the electrical connections.



When disassembling, check the position of the marks as illustrated and when re-assembling return them to the same position.

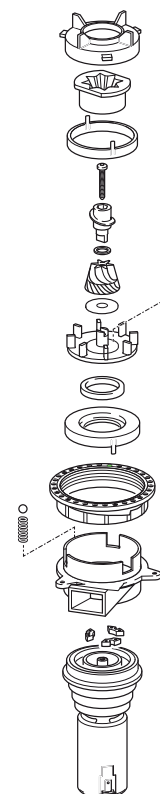

Coffee grinder exploded view

7.3. Grinder blades

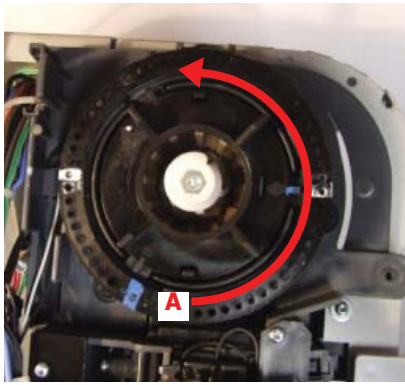

To slide out the upper grinder support turn the nut (A) anticlockwise until it is released.

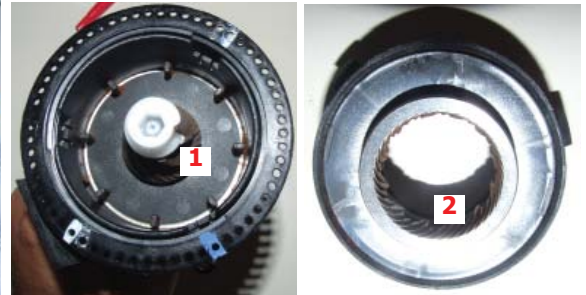
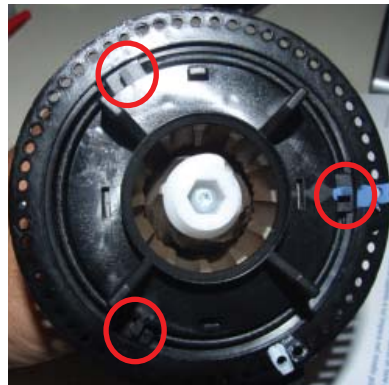

Lower grinder (1) and upper grinder (2).

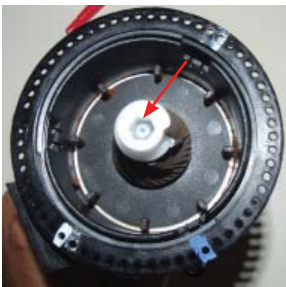

Loosen the screw as illustrated and slide out the lower grinder. When re-assembling take care to replace the three springs and three balls correctly.

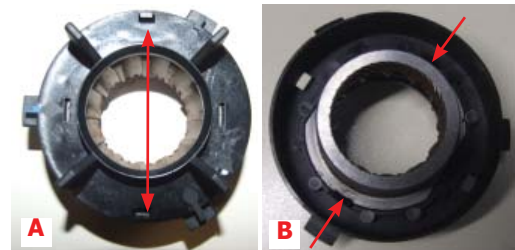

Release the upper grinder lid by pressing on the fins as illustrated (A) and remove the grinder by unhooking the catches as illustrated (B).

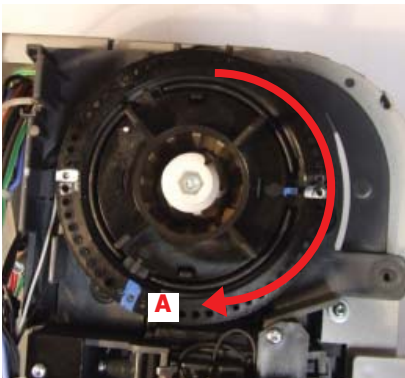

To adjust the distance between the grinders

- reconnect the coffee grinder and switch on
- turn the adjusting ring (A) slowly clockwise until the two grinders touch each other
- turn the adjusting ring (A) anticlockwise one notch.

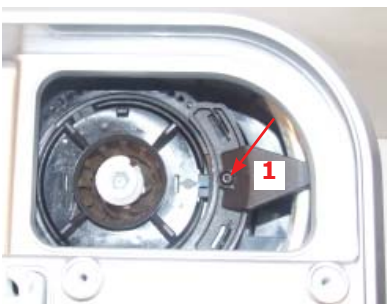

When reassembling the adjusting lever (1) position it in the center (2) and tighten the screw as illustrated.

7.4. Coffee grinder motor

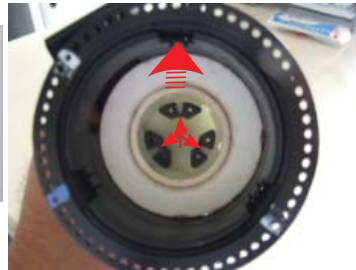

Remove the balls as illustrated, the springs underneath and lift up the grinding support.

Remove the three grinding dampers and the felt ring.

Release the motor support by lifting the catches as illustrated and replace the motor.

7.5. Doser hatch, coil and microswitch

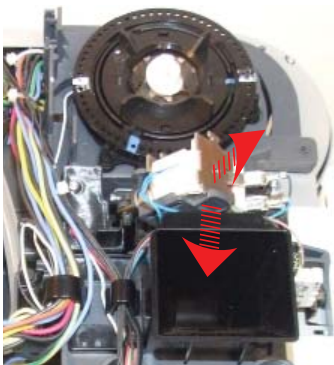

Release the catch as illustrated and lift the coil.

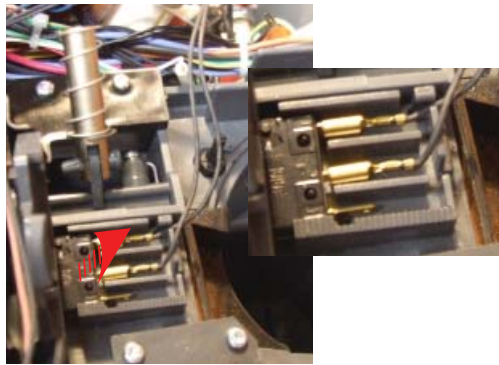

Remove the electrical connections and slide out the microswitch.

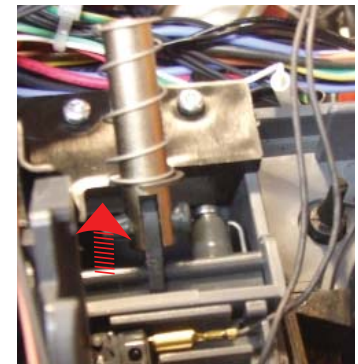

Lift the doser hatch using a lever in the pin and slide it out.

7.6. Doser hopper

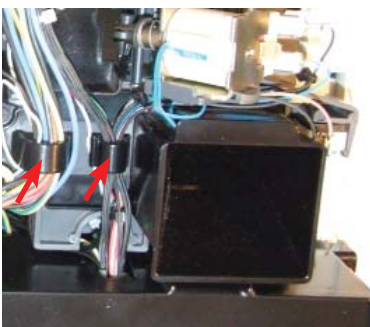

Remove the cabling from the cable grips as illustrated.

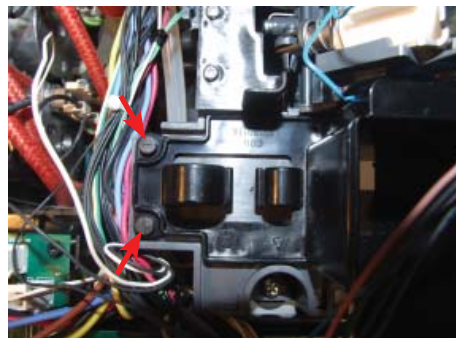

Lift the hopper and release it from the rubber hooks as illustrated.

7.7. Coffee boiler and steam boiler



Loosen the screws as illustrated and remove the boiler pin.

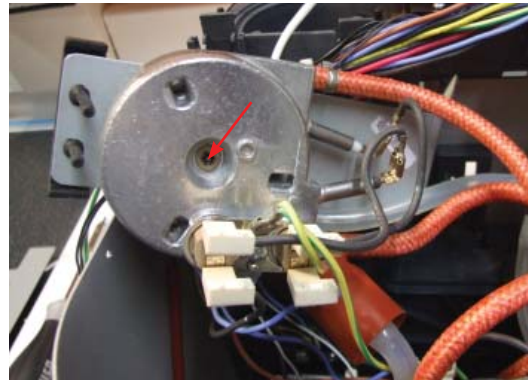

Loosen the screw as illustrated, remove the boiler support and disconnect the electrical and water circuit connections.

7.8. Boiler pin



Loosen the screws as illustrated and remove the boiler pin cover.

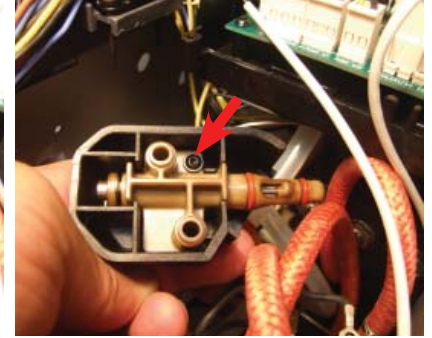
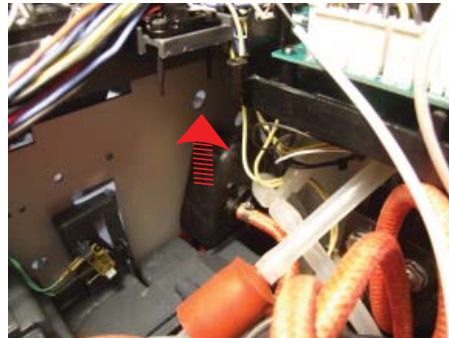

Slip off the pin support and loosen the screw as illustrated.

7.9. Coffee pump and steam pump

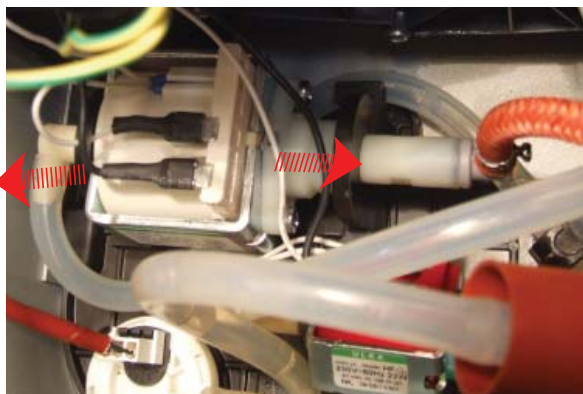

Remove the boiler support, lift the pump upwards from the two supports and disconnect the electrical and water circuit connections.

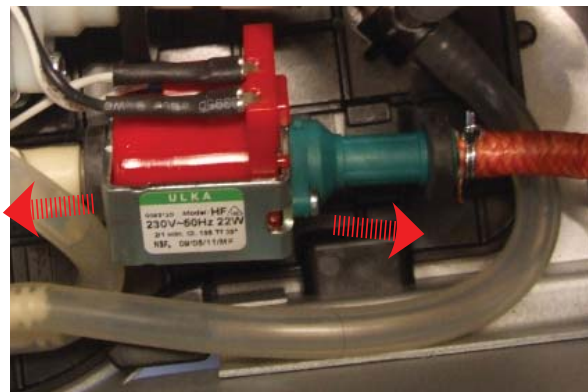

Remove the boiler support, lift the pump upwards from the two supports and disconnect the electrical and water circuit connections.

7.10. Flow meter

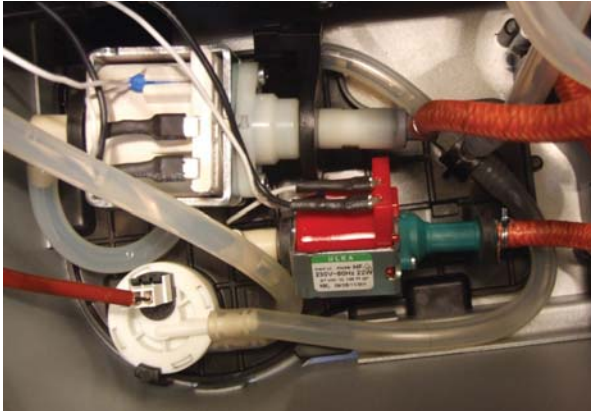

Remove the boiler support lift the flow meter upwards and disconnect the electrical and water circuit connections.

7.11. Gear motor

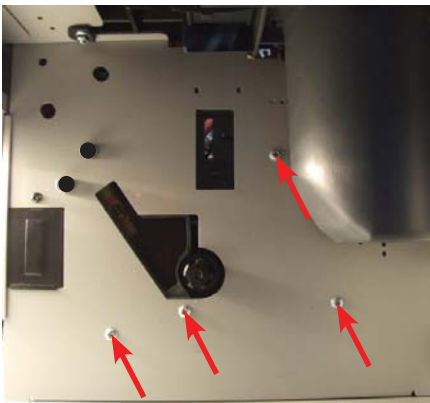

Loosen the screws as illustrated and remove the gear motor assembly.

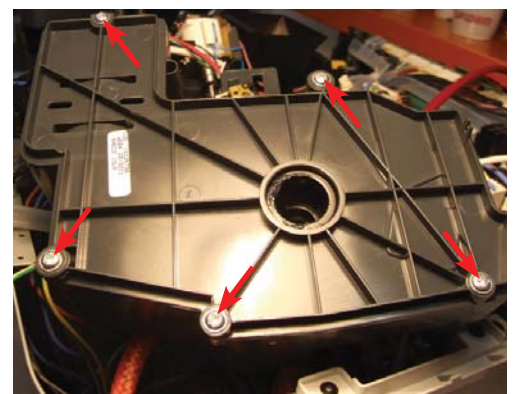
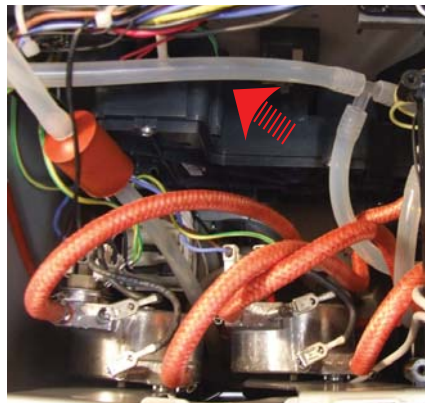

Loosen the screws as illustrated and remove the gear motor cover.

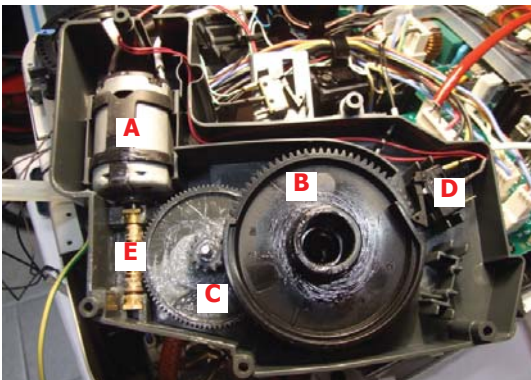

The following are located inside the compartment protected by the casing:

- Electric motor (A) with gears (B) and (C) for transmission and timing of the brewing unit.
- Microswitch (F) detecting brewing unit home and work positions.
- Remove the large gear (B)
- Remove the gear (C) that meshes with the motor transmission shaft
- Remove the motor (A), complete with transmission shaft (E)

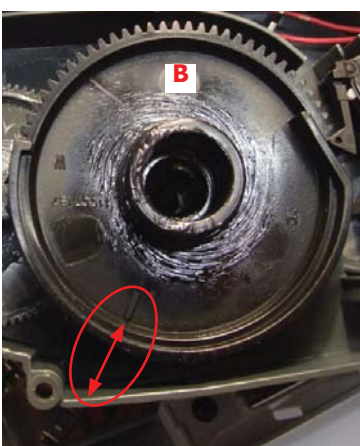

When re-assembling the gear (B), make sure that the arrow on the gear is in the same position as shown in the photo.



When replacing the motor and the transmission shaft, make sure the guide runners (L) are in the right position. Grease the shaft thoroughly and evenly.

7.12. Relief valve

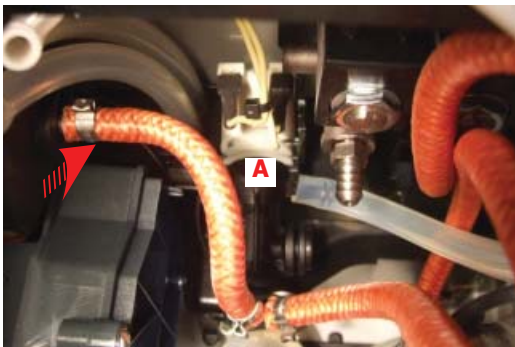

To remove the discharge valve (A) as illustrated firstly loosen the screws which hold the boiler pin cover in place then remove it.

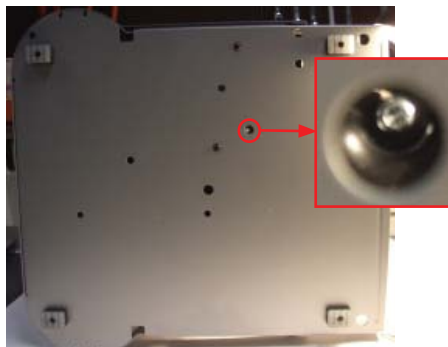

Loosen the screw under the machine as illustrated.

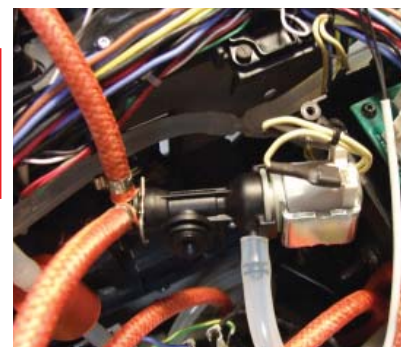

Disconnect all electrical and water circuit connections.

7.13. Solenoid valve assembly

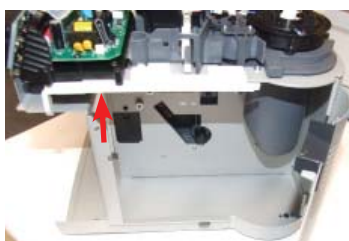

Loosen the screws as illustrated and slide out the card support to access the solenoid valve assembly more easily.



Remove the front body cover as follows:
 - Loosen the screw (A) as illustrated
 - Move the cover to the left to release the catches (B)
 - Lift the lower part of the cover to release the catch (C)
 - Pull outwards

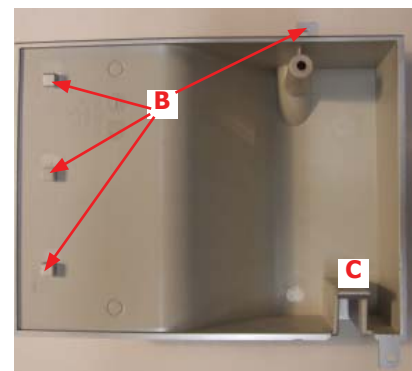

Loosen the screws under the front body cover as illustrated.



Disconnect the electrical and water circuit connections.



Loosen the screws on the support.

7.14. Steam pipe assembly

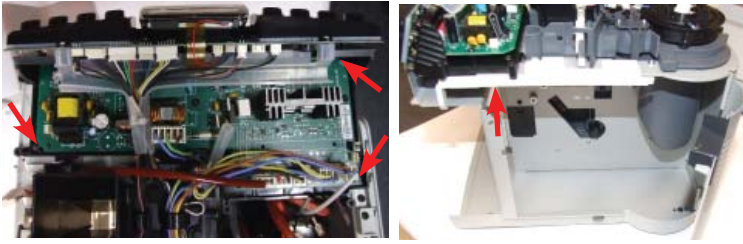

Loosen the screws as illustrated and slide out the card support to access the solenoid valve assembly more easily.

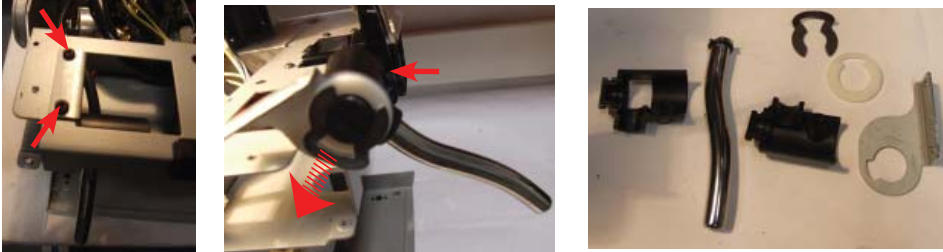

Loosen the screws as illustrated and remove the clip.

7.15. Dispenser assembly

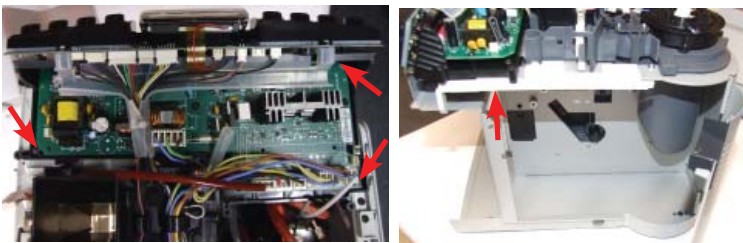

Loosen the screws as illustrated and slide out the card support to access the solenoid valve assembly more easily.

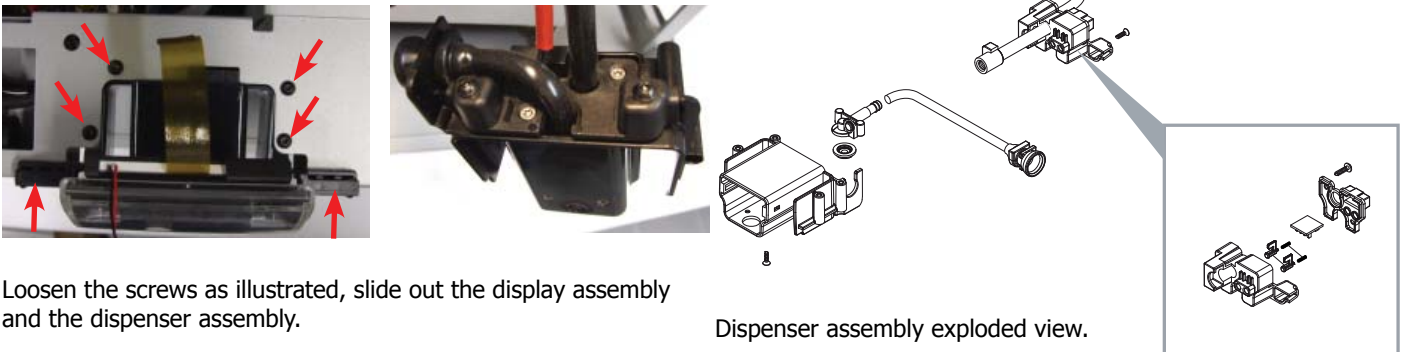

Loosen the screws as illustrated, slide out the display assembly and the dispenser assembly.

Dispenser assembly exploded view.

7.16. Power board



Loosen the screws as illustrated and remove the card cover.

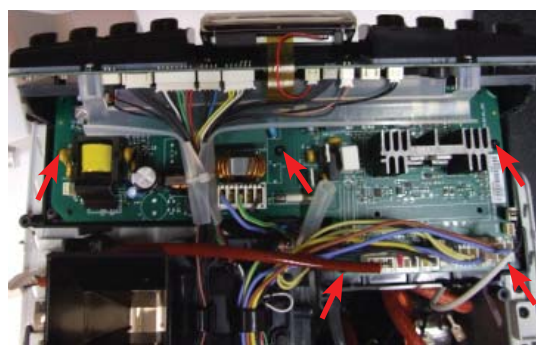

Loosen the screws as illustrated, remove the card cover and disconnect the electrical connections.

7.17. Display, keypads and control board

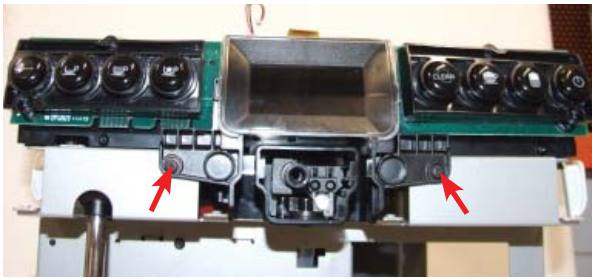

Loosen the screws as illustrated and disconnect the electrical connections and remove the display assembly.

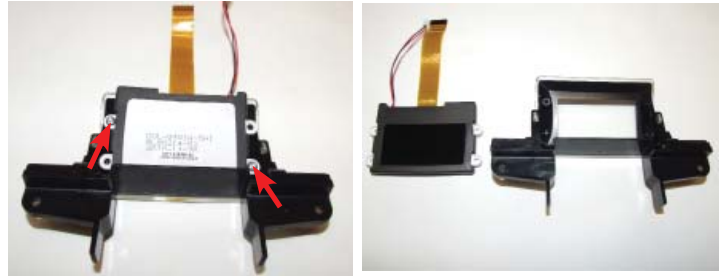

Loosen the screws on the back of the display assembly as illustrated.

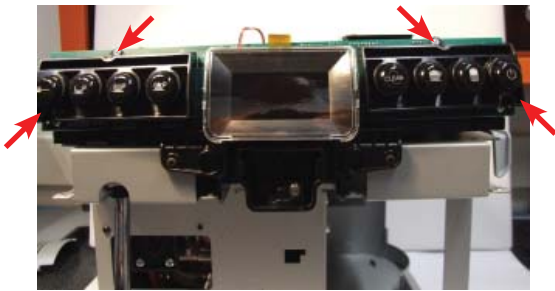

Loosen the screws shown and slide out the keypads.



Loosen the screws as illustrated and disconnect all electrical connections.

7.18. Fitting and removing Oetiker clamps

Control board and display card assembly

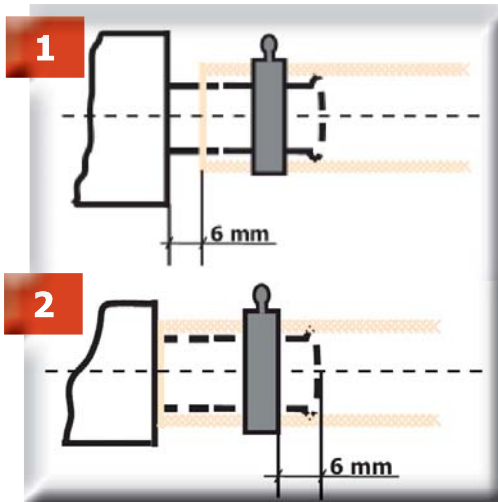

1) Boiler connection

2) Other connections

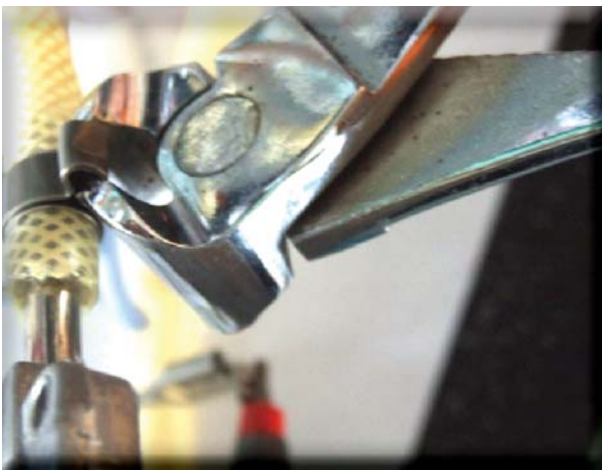

Use a suitable pair of pliers to remove the clamp (as illustrated).



Tighten the clamp as illustrated.



CHAPTER 8

NOTES



CHAPTER 9

WATER CIRCUIT DIAGRAM

New Royal

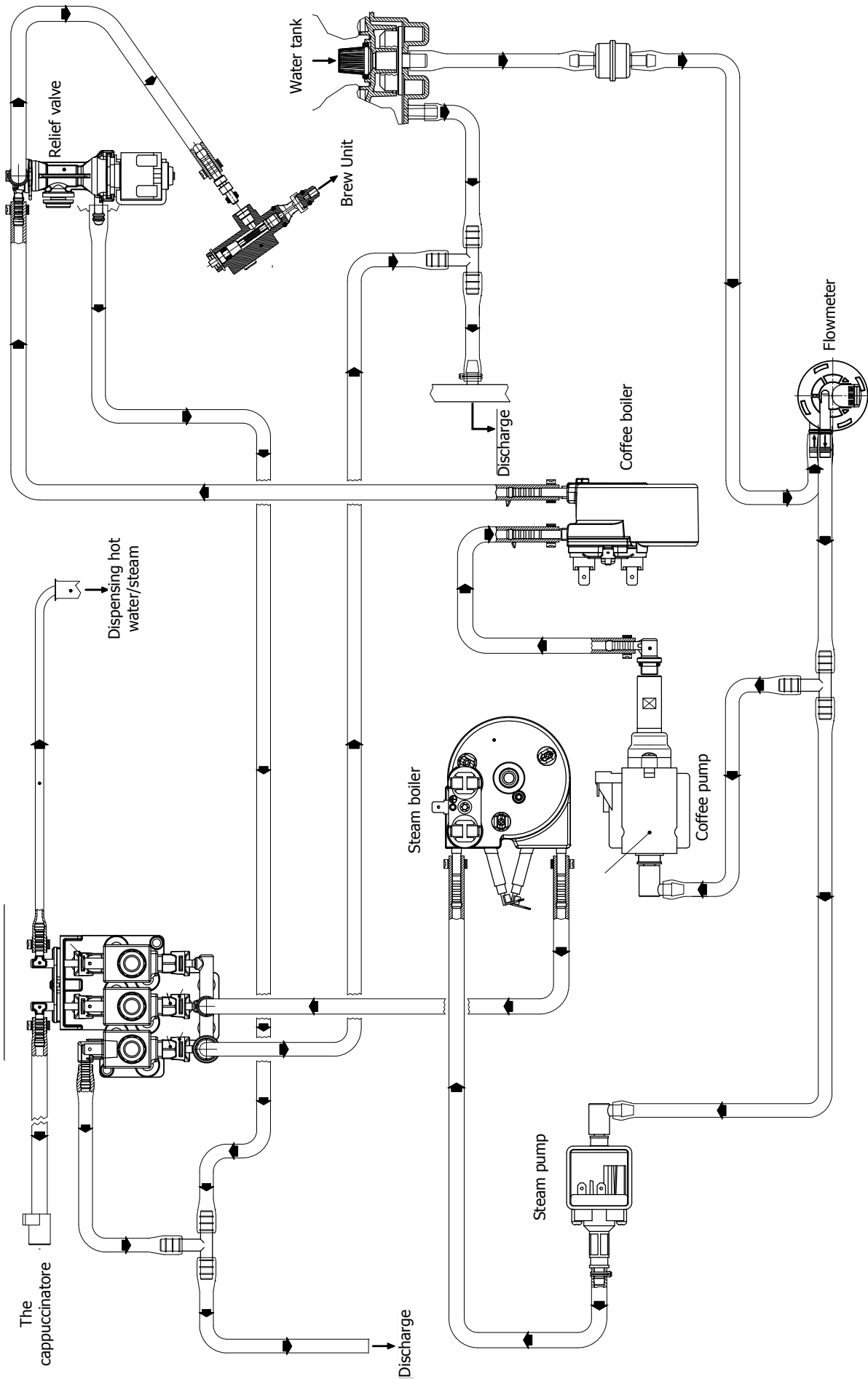

Royal Gran Crema

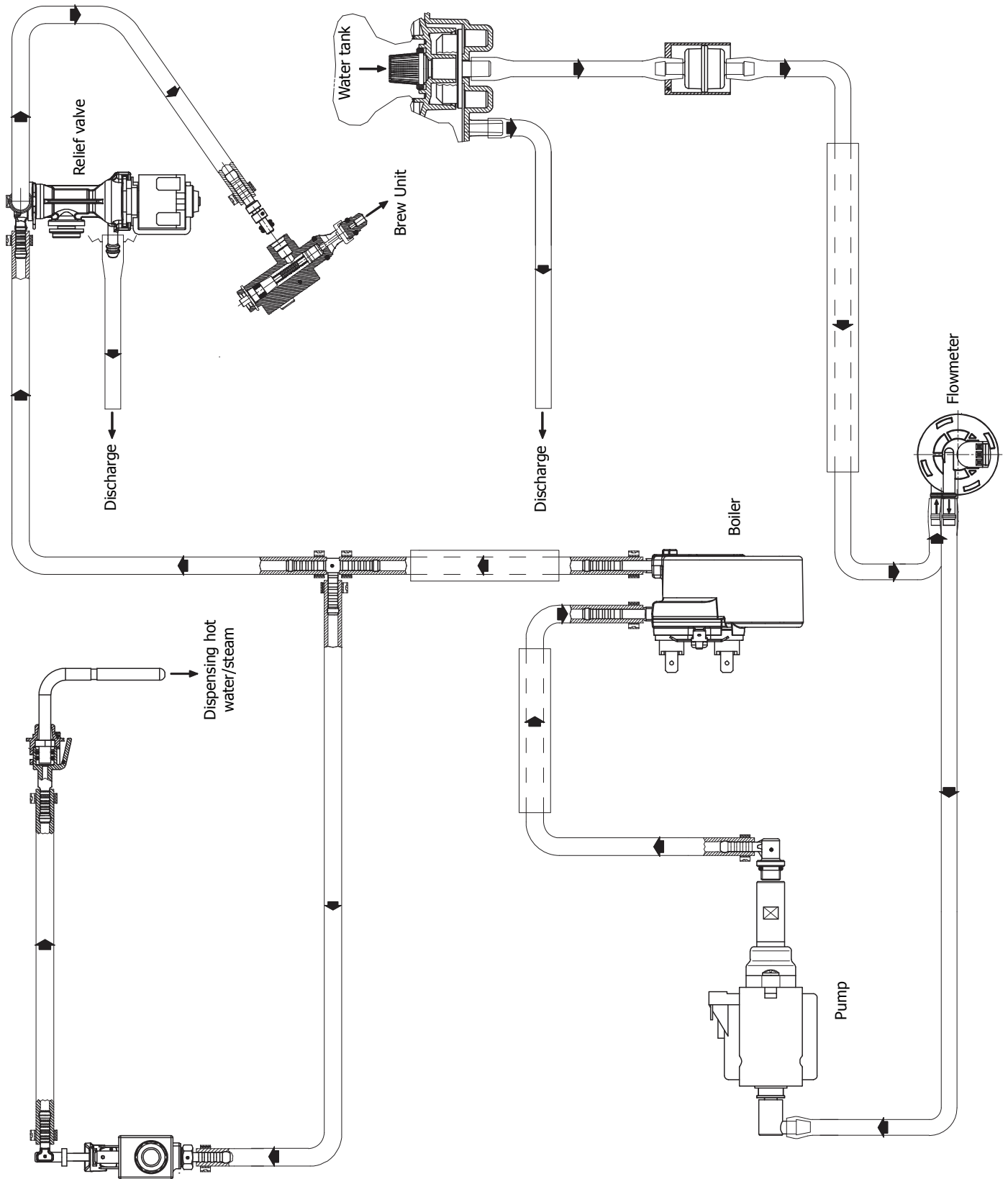

A large, light gray, stylized letter 'E' watermark is centered on the page. It has a thick, rounded font style with a slight shadow effect.

CHAPTER 10

ELECTRICAL DIAGRAM

New Royal

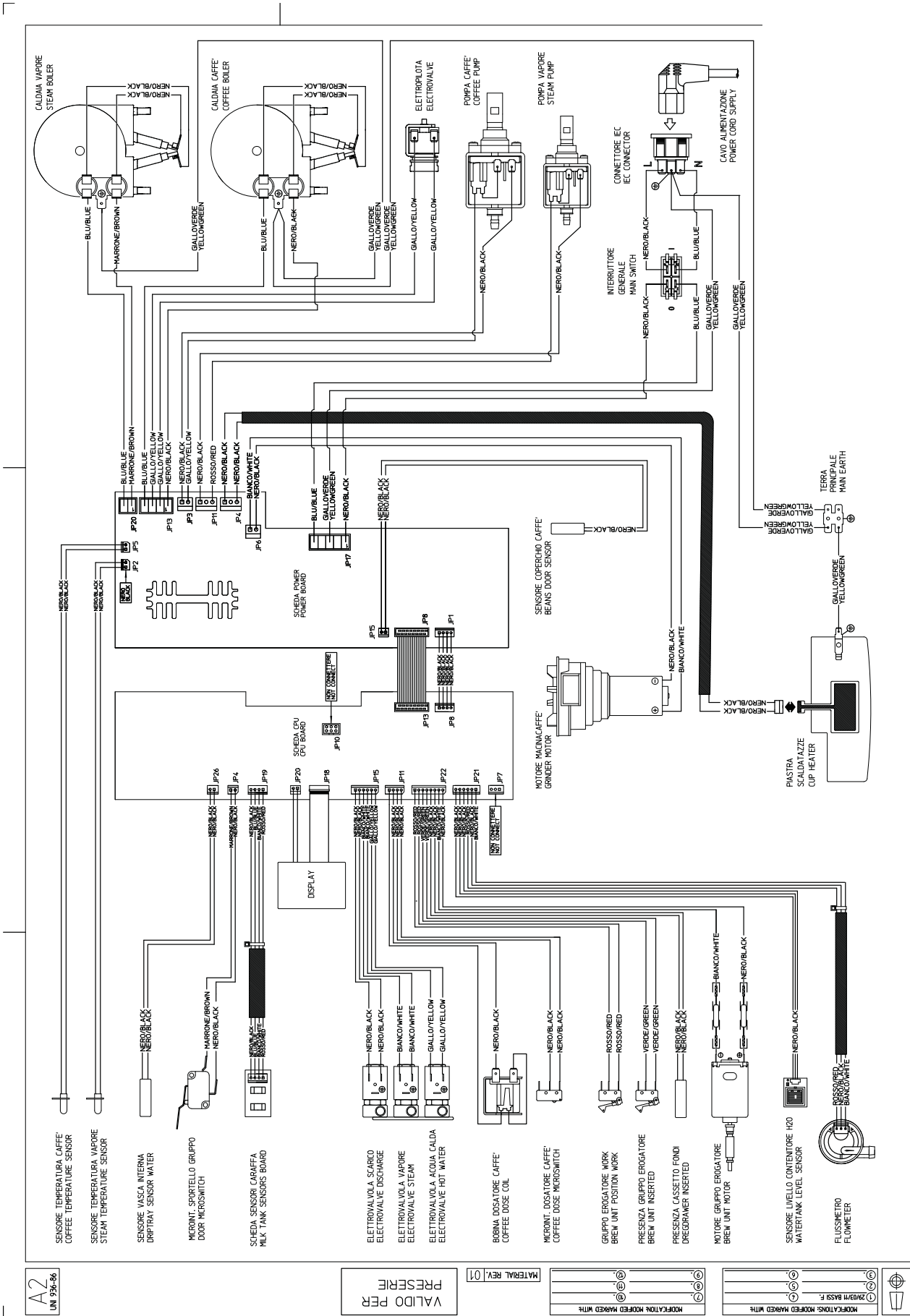

A2
UN 934-86

VALIDO PER
PRESERIE

MATERIAL REV. 01

MARKKATJONS MERKED MARKED MARKED WITH

MARKKATJONS MERKED MARKED MARKED WITH
ZM/03 BASS F.

Royal Gran Crema

100V AND 120V VERSIONS DIFFERS FROM THE 230V VERSION FOR:
EARTH CABLE COLOR: GREEN IN PLACE OF YELLOW-GREEN.
FASTON PIGGYBACK ON DOUBLE CRIMP OF EARTH WIRES.

