



Philips Consumer Lifestyle

Service Manual

PRODUCT INFORMATION

Safety info

- This product meets the requirements regarding interference suppression on radio and TV.
- After the product has been repaired, it should function properly and has to meet the safety requirements as officially laid down at this moment.

- SAP coding : HD9220/40
HD9220/42
HD9220/44

OPTIONAL (accessories)

- Baking dish 4222 459 52761

TECHNICAL INFORMATION

- Voltage : 220 - 240V
- Frequency : 50 - 60 Hz
- Power consumption : 1425 W
- Product dimensions (W x H x D) : 287 x 315 x 384 mm
- Cord length : 1 meter
- Materials : Outer skin : Plastic (PP)
Pan : Aluminized steel
Basket : Aluminized steel
Basket mesh : Stainless steel
Coating : PTFE coating
- Capacity : 2.2 liter
(till max indicator)
- Weight : 7.0 kg
- Coloursetting : White, Lavender
- Temperature : 80 till 200 °C
- Fuse cut-off temp. Motor : 145 °C
TCO : 190 °C

IMPORTANT:

When you replace the pan (basketholder) or basket, first check production week on the bottom of the appliance to find out which part(s) you need to order:

HD9220/4x	Pan		Basket	
1111	4222 459 54141	and	4222 459 54121	Due to compatibility issues, make sure you order both components
1111 > 1136	4222 459 54141	or	4222 459 51791	Components are compatible no need to be ordered both at once
> 1136	4222 459 54141	or	4222 459 54121	Components are compatible no need to be ordered both at once

Part/ System	Test	Possible deviation	Analyses	Replace (depending of the analyses outcome)
Timer	Check if the green light is lit, and if you can hear the timer ticking	The green light is not lit but the timer is ticking	Check the timer-switch and the fuse with a multimeter	Timer/Fuse
		The green light is lit but the timer is not ticking	Timer is defective	Timer
Thermostat	Set the temperature at 80 °C and check if the heating element is getting warm (Check input power approx. 1425 W) The green light should be lit and the orange light should switch off after it reaches 80 °C	Both green and orange light are lit but there is no heating	Check the heating element with a multimeter	Heating element
		If the green light is lit and the orange light is off	Check the thermostat with a multimeter	Thermostat
		If both the green and orange light are off	Check the timer and fuse with a multimeter	Timer/Fuse
		The orange light does not switch off after reaching approx. 80 °C	Thermostat is defective	Thermostat
Motor fan assy	Set the timer and listen if the motor is running	Motor is not running	The fan is scraping the housing turning it by hand (Switch off the power when you do this test!)	Motor fan assy
			The fan is not scraping the housing turning it by hand (Switch off the power when you do this test!): Check the motor fan assy, timer and fuse with a multi meter	Motor fan assy / Timer/Fuse
Heating element	Check if the heating element is getting warm (Check input power approx. 1425 W)	If the Orange light is on and the heating element does not heat	Check the heating element with a multimeter	Heating element
		If the heating element does not heat and the orange light is off	Check the timer, fuse and thermostat with a multimeter	Timer/Fuse/ Thermostat
Thermal fuse	Set the timer and check if the green light is lit	Green light is not lit	Check the timer and fuse with a multimeter	Timer/Fuse

General remark;

When you need to disconnect a wire from the crimp housing, please cut the wire half way (See \approx in the picture below) and always connect the wires with a new 2 wire crimp housing 4222 459 51851. To crimp the housing use the Lobster AK25 No2 or Muromoto Tekko MR30A Nr 2 with Air pressure = 6 kg/cm².

Crimp instruction CE2

- 1) Strip wires: 16mm (0.63 in) Max. 13mm (0.51) Min.
- 2) Twist the wires together along the entire length of the strip and insert them into crimp housing .
- 3) Center the crimp tool on the sleeve.
- 4) Crimp the housing with 6 kg/cm².

Route the wire route, using 5 tie-wraps according the picture below;

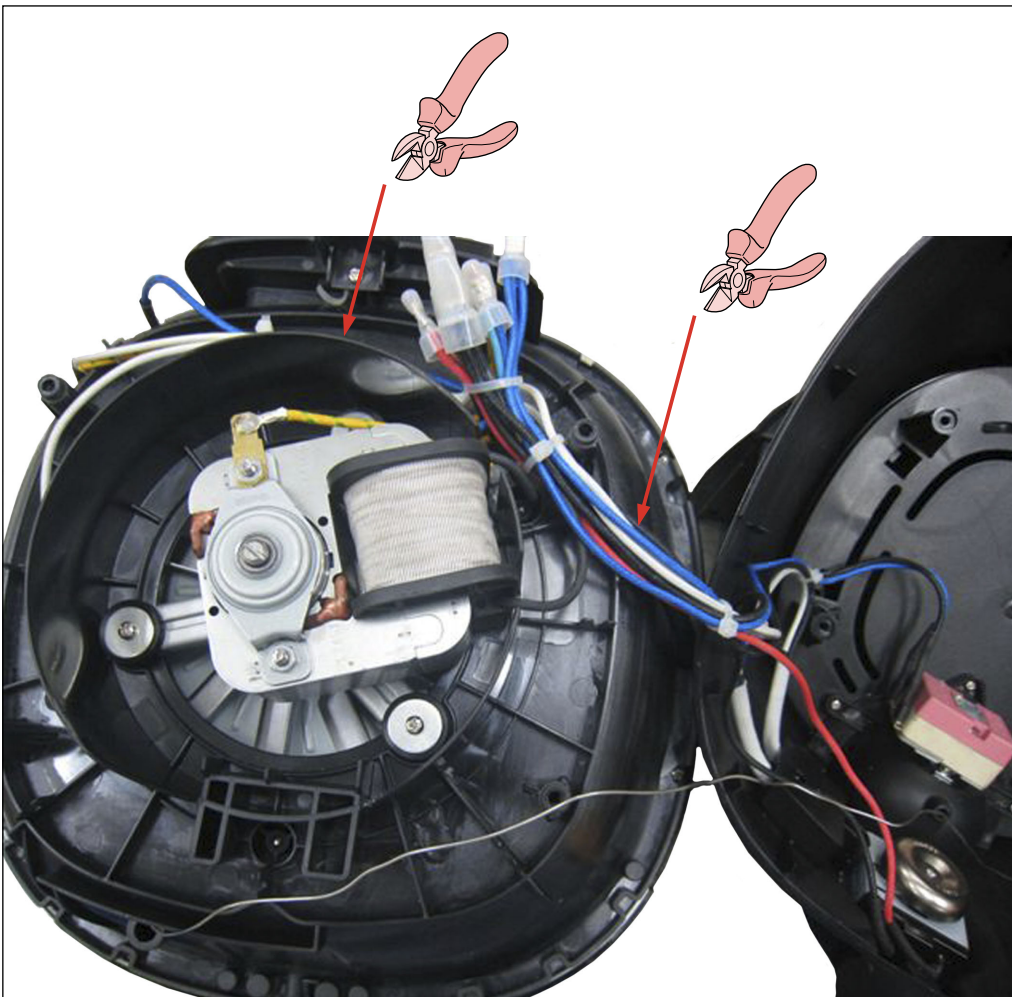

A. Top cover removal

1. Open the cover from the top cover by using a flathead screw driver to open the 6 click connections.

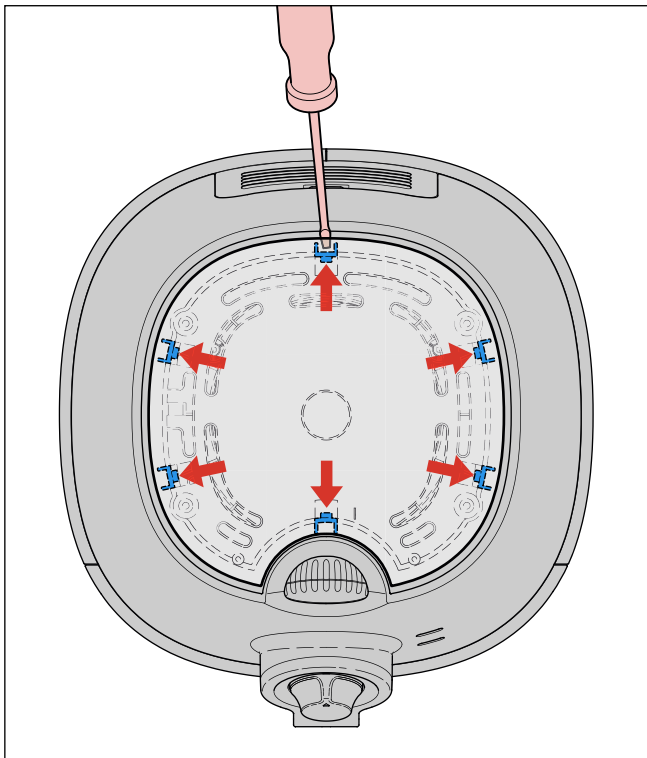

2. Use a crosshead screw driver to unscrew the 4 screws **A**.

Note: When you close the top cover, use a screw torque off 50 till 80 Nm (5 to 8 kgf.cm)

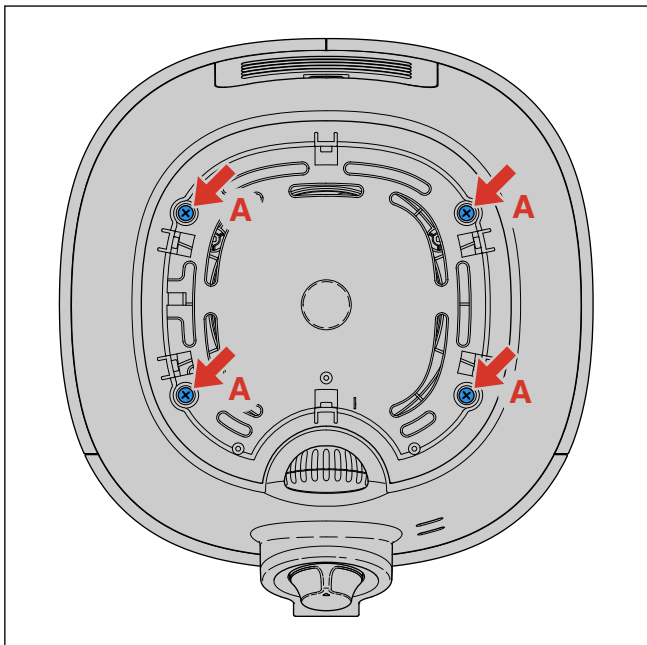

3. Use a flathead screw driver to open the “timer top cover” and pull the knob from the appliance.

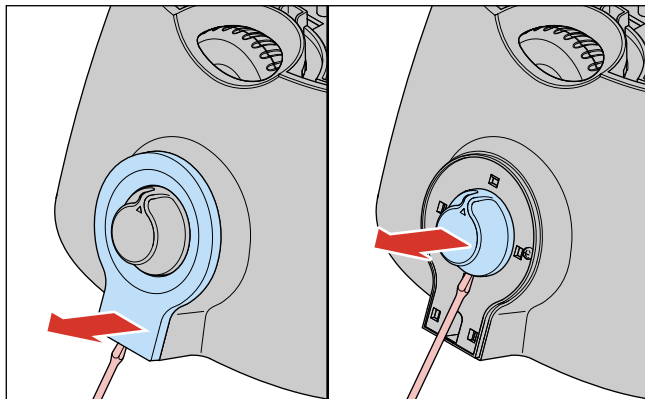

4. Unscrew the screw **B** under the timer top cover.

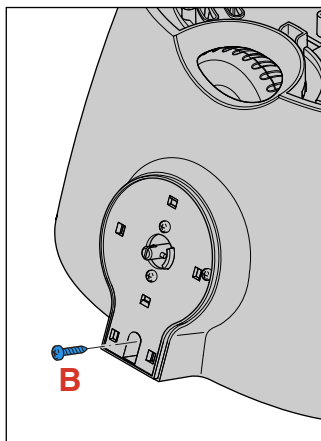

Note: Replace the timer cover and / or the cover in case of damage and / or scratches.

Tip: Open the “timer cover” from the bottom side, to avoid scratches on visible places.

B. Cover housing removal

1. Follow previous step **A**
2. Open the motor fan assy from the base by unscrewing the 6 screws **C**. Be aware of the 2 screws under the filter.

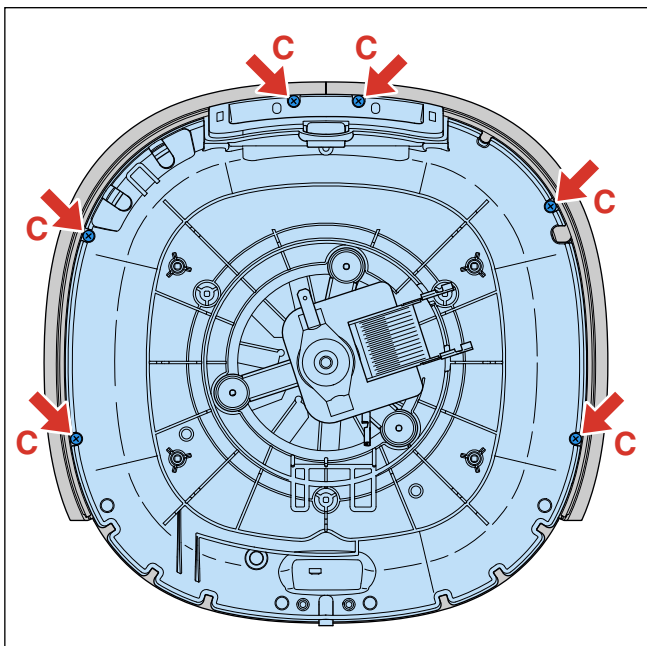

D. Double heat shield removal

1. Follow previous step **A, B** and **C**
2. Remove the double heat shield out of the motor fan assy by unscrewing the 3 screws **E**.

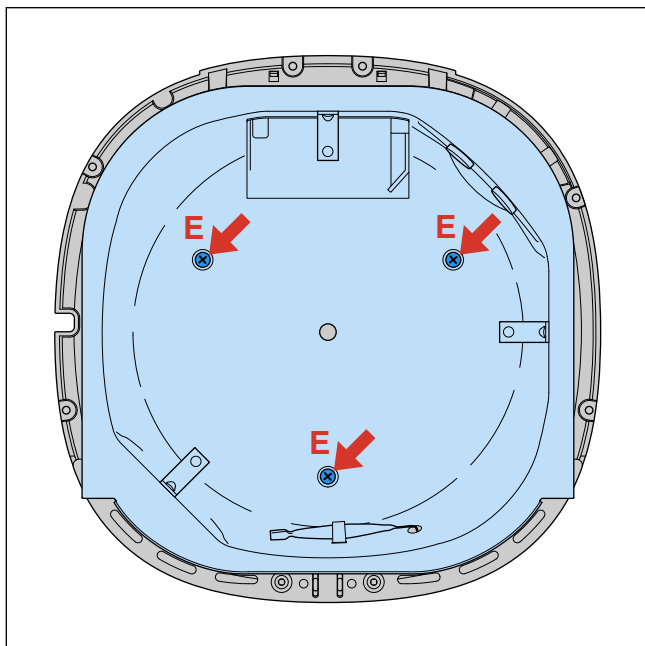

C. Heating element + Fan Removal

1. Follow previous step **A** and **B**
2. Undo the heating element from the double heat shield by unscrewing the 3 screws **D**.

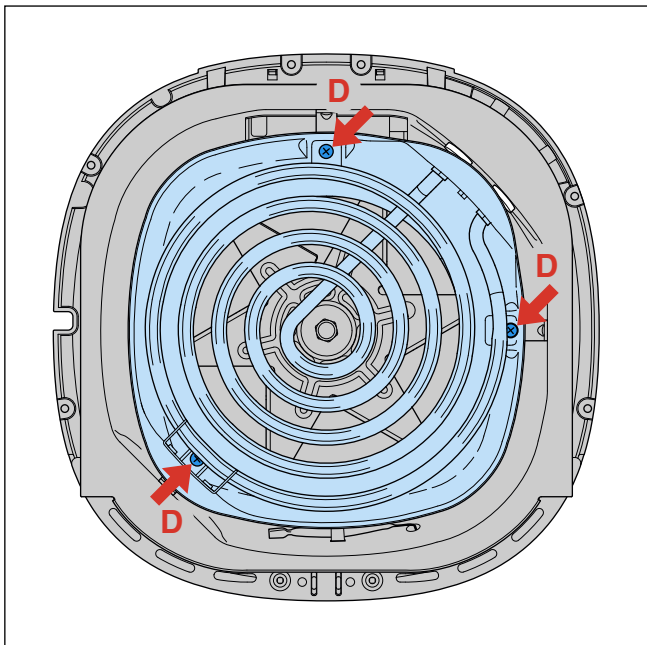

E. Timer removal

1. Follow step **A**
2. Unscrew the 2 screws **F** behind the timer knob.

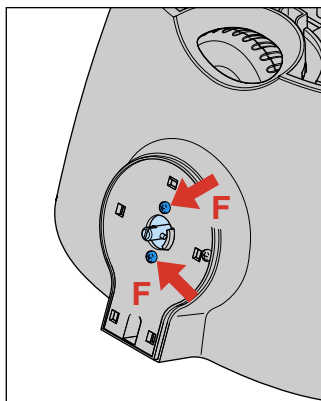

3. Remove the wires of the timer.

3. Cut the 2 heating element wires halfway and remove the heating element.
4. Undo the nut from the left screw thread and remove the fan.

F. Thermostat removal

1. Follow previous step **A**
2. Remove the 3 screws **G** from the thermostat assy.

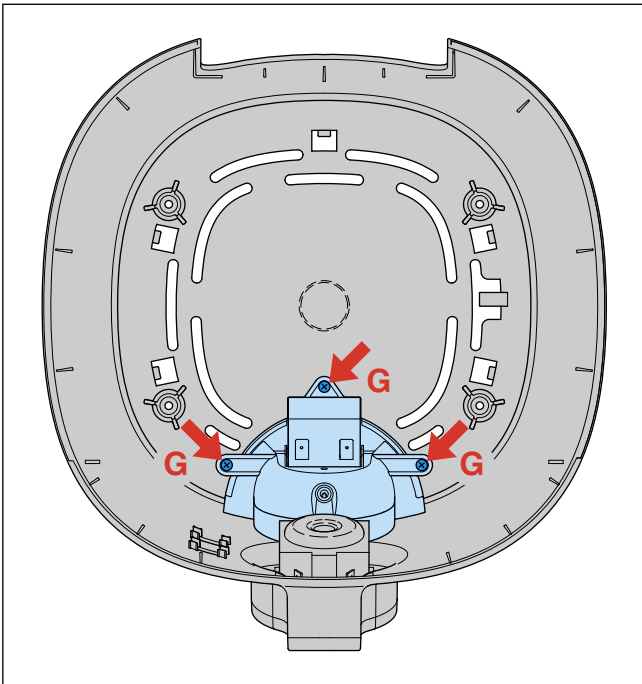

3. Follow previous step **B, C, D**
By step **C** do not cut the wires.
Note: be careful with the wire / heating element connecting, this connection is fragile.
4. Remove the thermostat sensor by undoing the metal band.

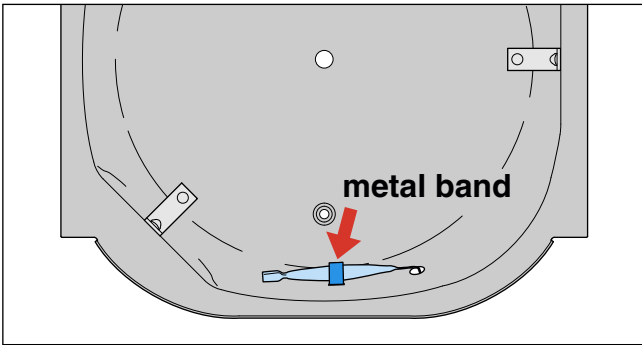

Note: Please make sure while re-assembling the new thermostat that the routing will be done as shown in below picture.

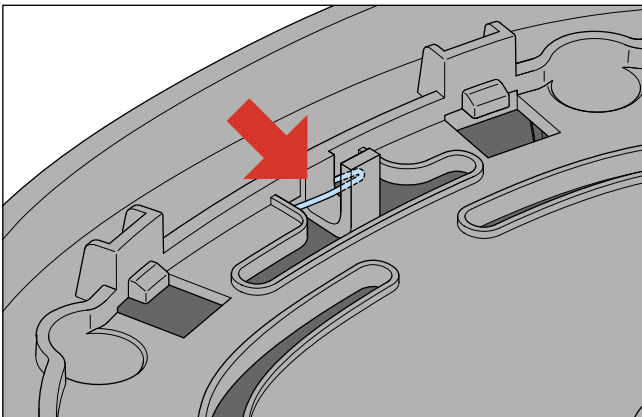

G. Motor assy removal

1. Follow previous step **A, B, C, D**
By step **C** do not cut the wires.
2. Remove the thermostat sensor (See instruction **F 4**)
3. Remove the fuse and the earth connection from the double heat shield.

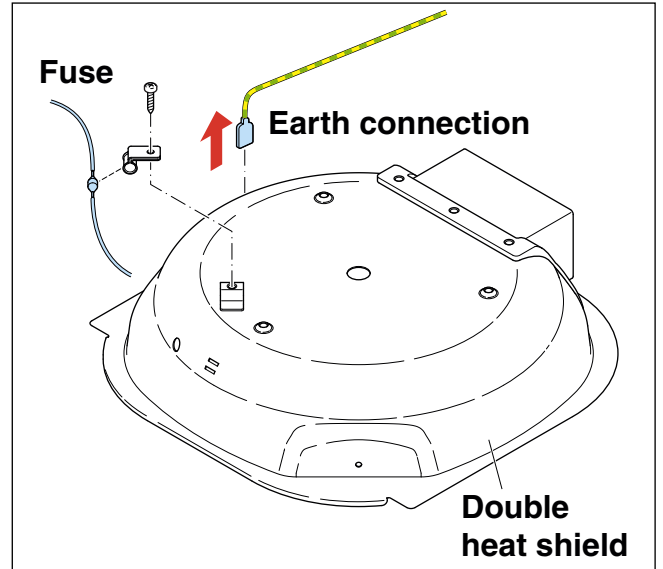

4. Cut the motor wires half way and remove the motor fan assy.

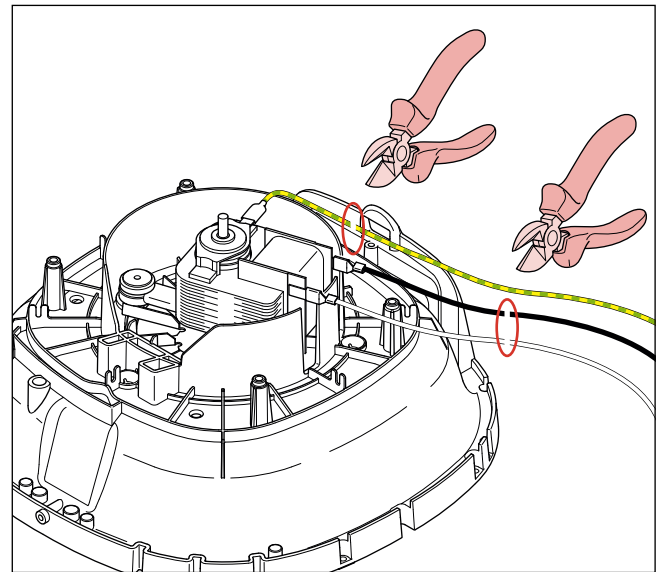

Pos	Service code	Description	
1	4222 459 51861	Cover	Lavender
2	4222 459 51811	Timer knob	Purple
3	4222 459 51821	Timer cover	Lavender
4	4222 459 51901	Food separator	
5	4222 459 51791 4222 459 54121	Basket*	>wk1111 <wk1136 all other prod. wks Lavender
6	4222 459 54141	Pan (Basket holder)**	Lavender/White
7	4222 459 51911 4222 459 54671	Rubber foot Rubber foot	<wk1116 >wk1116
8	4222 459 51841	Top cover	Lavender
9	4222 459 53251	Stainless steel timer	
10	4222 459 49181	Fuse incl. wires	
11	4222 459 49141	Fan	
12	4222 459 49131 4222 459 53391	Heating element incl. wires Heating element incl. wires	220-240V, 50 Hz 220-240V, 60 Hz
13	4222 459 51831	Base incl. wires	White
14	4222 459 53071	Thermostat assy CCW incl. standard knop U	Lavender
15	4222 459 49201 4222 459 53401	Motor, fan assy Motor, fan assy	220-240V, 50 Hz 60 Hz
16*	4222 459 52761	Baking dish	
	4222 459 51851	10 pieces of 2 wire crimp housing (CE-2)	

* **Optional**

** **Note** When your appliance prod. wk is before WK1111 you need to replace both the basket and pan at the same time because of compatibility issues.

Electrical circuit

When the appliance does not work, check the electrical circuit.

Open de lid panel always on the underside. Always replaces this panel in case of damaged, scratches body or broken click connection.

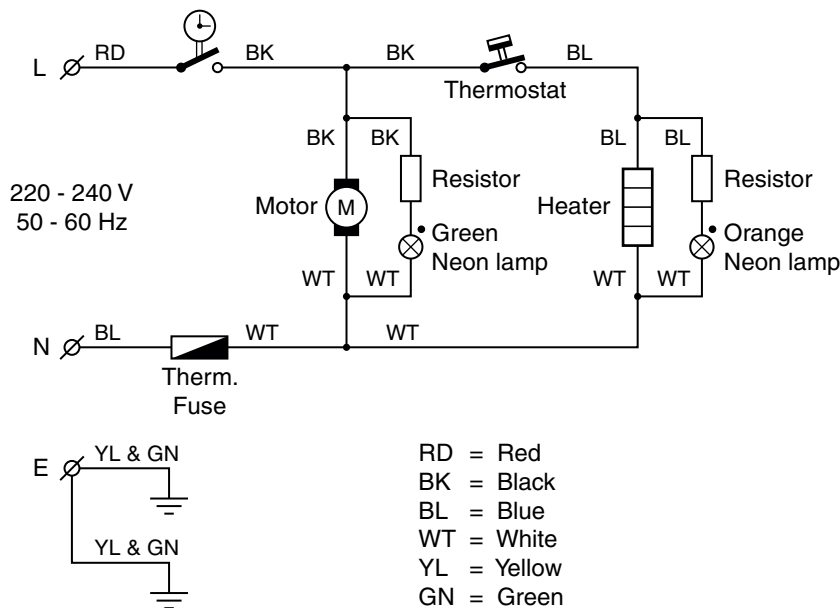

■ = changed

