

Service
Service
Service



Philips Consumer Lifestyle

Service Manual

PRODUCT INFORMATION

- Product meets the requirements regarding interference suppression on radio and television.
- After the product has been repaired, it should function properly and has to meet the safety requirements as laid down officially established at this moment.

TECHNICAL INFORMATION

- Input voltage : 220 - 230 V / 50 - 60 Hz
: 220 V / 50 Hz
: 220 V / 60 Hz
: 110 V / 60 Hz
- Input consumption : Approx. 650 W
- IR source : Sylvania IR 650 W / 230 V
: Sylvania IR 650 W / 115 V
- Timer : 15 minutes
- Weight : 7,9 kg

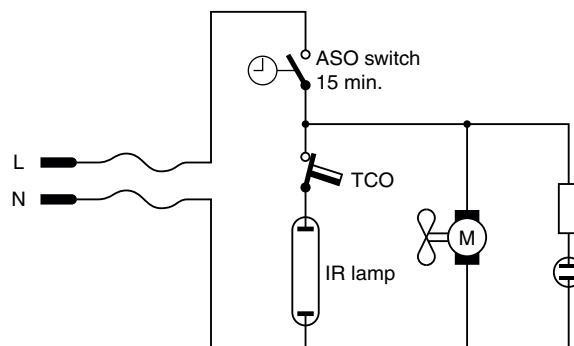

DISASSEMBLY- AND RE-ASSEMBLY ADVISE

How to exchange a lamp and/or switch

- Undo and remove the 8 screws at the back of the lamp housing.
- The lamp holders and the switch are now accessible.

Exchanging the lamp:

- Unscrew the lamp holder at one end and let the lamp slide out of the housing between the reflector and the glass pane.
- Put the reflector with the glass pane in vertical position, i.e. with its narrow end pointing downwards, and slip the lamp through the opening next to the lamp holder. Make sure the contact point of the lamp rests properly on the contact point of the lower lamp holder.
- Tighten the lamp holder and make sure the contact points are seated properly.

REPAIR INSTRUCTION

To replace the filter:

1. Open the device.
Be aware you keep the wiring in place.

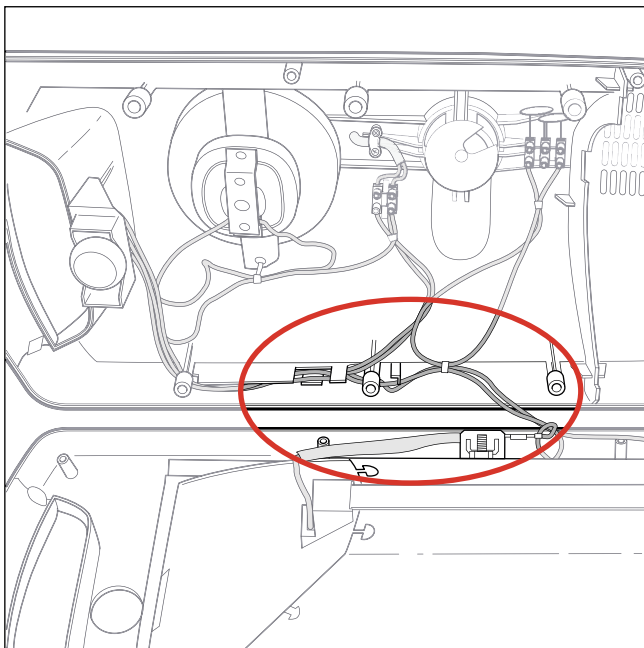

2. Unscrew one lamp holder.

3. Lift up the lamp out of the reflector.

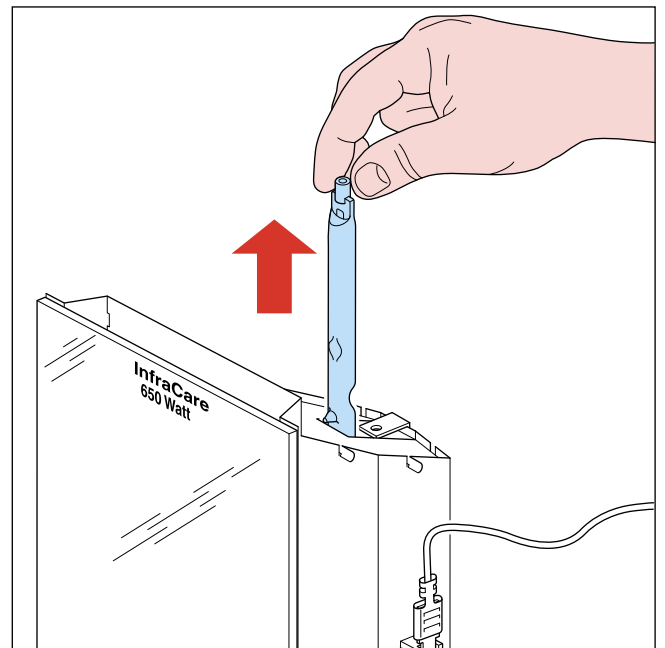

4. Remove the other lamp holder and unplug the wires.

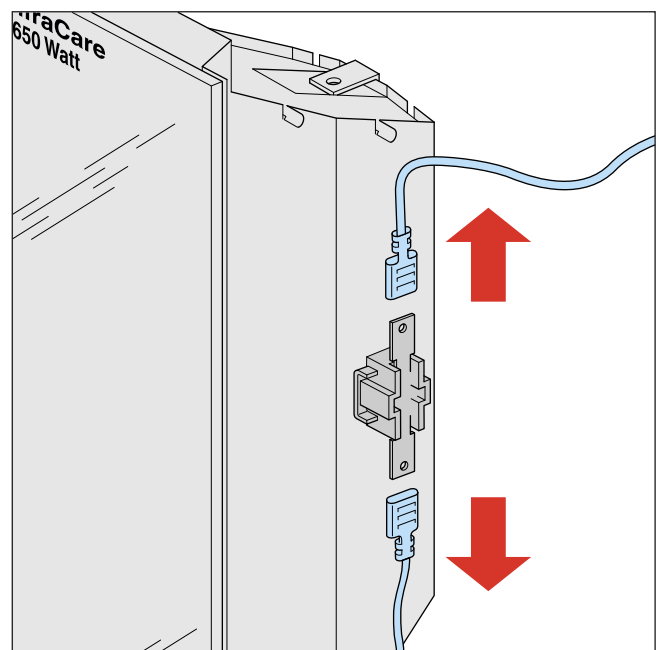

5. Replace the whole reflector unit.

OPTIONAL (accessories)

- No specific issues.

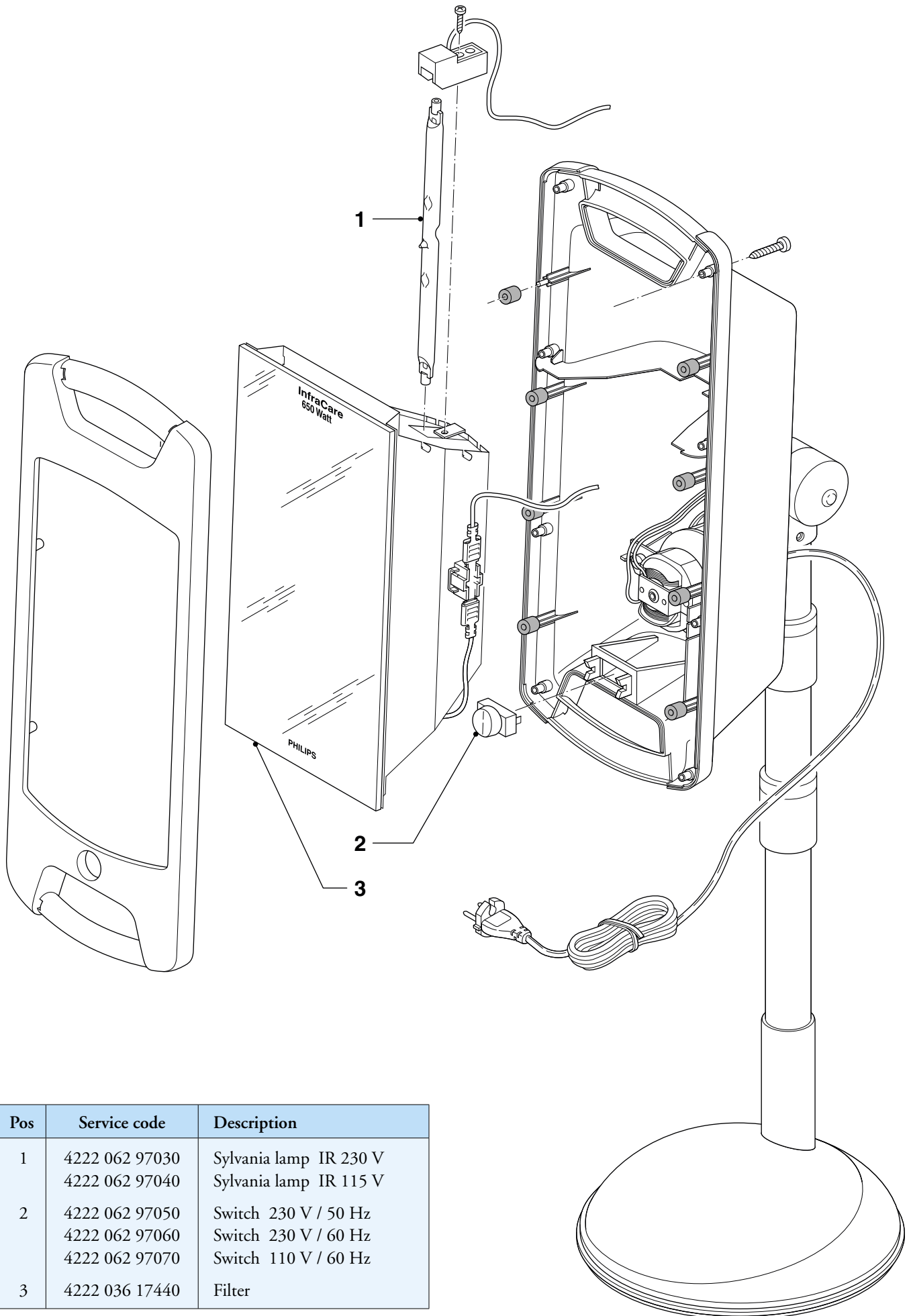

Pos	Service code	Description
1	4222 062 97030	Sylvania lamp IR 230 V
	4222 062 97040	Sylvania lamp IR 115 V
2	4222 062 97050	Switch 230 V / 50 Hz
	4222 062 97060	Switch 230 V / 60 Hz
	4222 062 97070	Switch 110 V / 60 Hz
3	4222 036 17440	Filter