



Philips Consumer Lifestyle

# Service Manual

## PRODUCT INFORMATION

### Features

- HR1581/00 : 3 speed mixer + turbo

### Safety

- This product meets the requirements regarding interference suppression on radio and TV.
- After the product has been repaired, it should function properly and has to meet the safety requirements as officially laid down at this moment.

- Speed Switch functionality : Slider on top of handle
- Sliding direction f. activation : Backwards (to the rear), top view
- Self protecting system : Yes, TCO self holding
- Weight appliance : 1450 gr (only appliance)  
100 gr (only twisted wire beaters)  
100 gr (only dough hooks)
- Colour appliance : Eternity grey
- Cordset length : 1800 mm

## TECHNICAL INFORMATION

- Input Power : 360 Watt
- Voltage : 220 - 240 V
- Frequency : 50 - 60 Hz
- Cordlength : 1,6 m
- Speeds : 4 (incl. Turbo)
  - speed 0 : 0 rpm  
and physically off (no standby power)
  - speed 1 : 8500 rpm
  - speed 2 : 12000 rpm
  - speed 3 : 14000 rpm
  - speed Turbo : 16000 rpm
- tolerances for all speeds :  $\pm 10\%$
- Turbo : Yes (locked)

### Size of appliance (motor unit):

- Length : 190 mm
- Width : 80 mm
- Height : 180 mm

### Material description:

- Main housing material : Alu die cast
- Release mechanism : Yes, lever principle
- Dough Hooks : Yes, fully stainless steel
- Twisted Wire Beaters : Yes, fully stainless steel

## DISASSEMBLY- AND RE-ASSEMBLY ADVISE

- No specific issues

## REPAIR INSTRUCTIONS

Serial number explanation:

The serial number can be identified on the typeplate sticker.  
See example below.

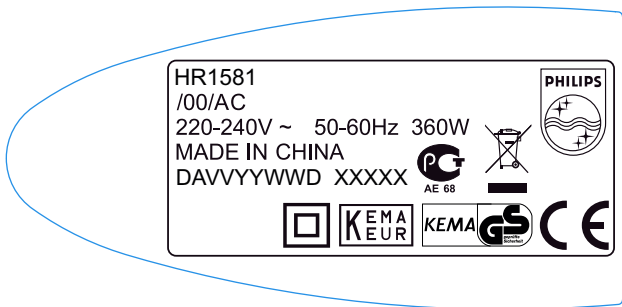

Unique appliance ID combined with production date:

DA00YYWWD xxxxx

DA (Domestic Appliances)

00 (used for major technical changes)

YY (Year)

WW (Week)

D (Day / 1 = Monday)

xxxxx (serial number, 5-digits starting at 00001 at first day of each production week)

## OPTIONAL (accessories)

- No specific issues

## Eternity MX - rough schematic

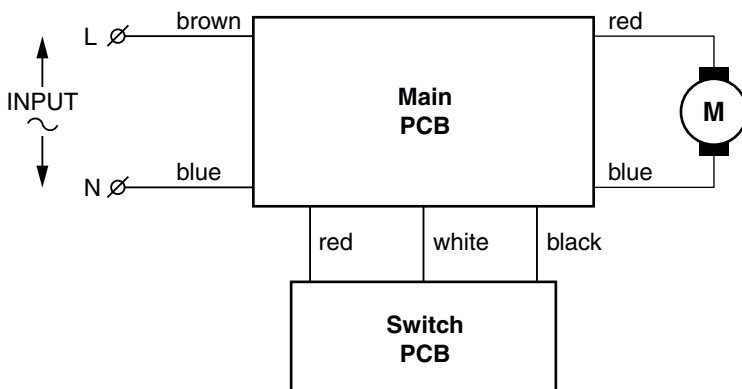

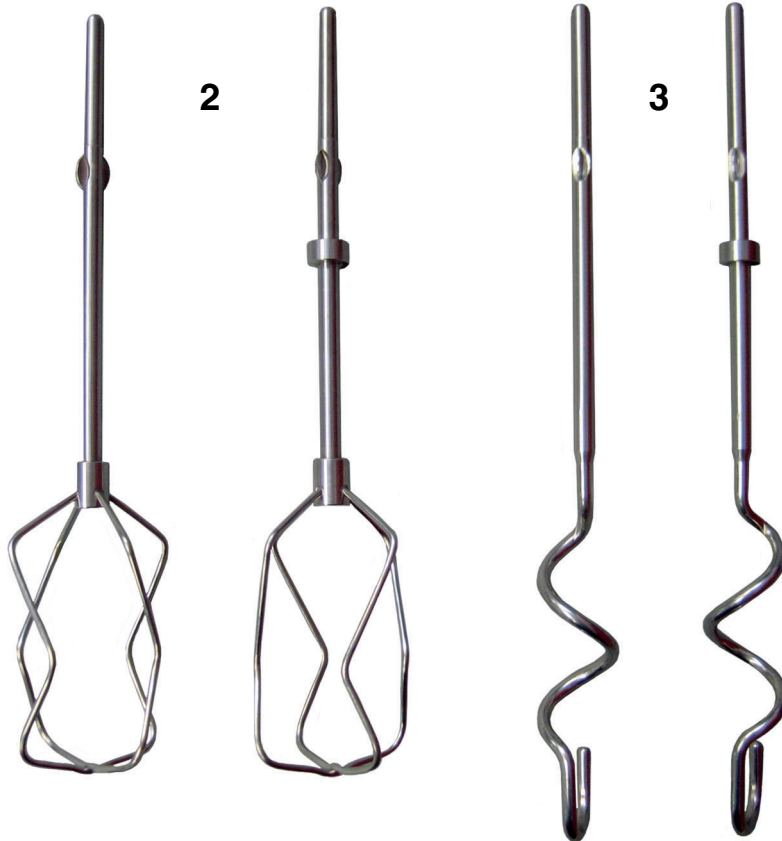

| Pos | Service code   | Description                  |
|-----|----------------|------------------------------|
| 1   | 4203 035 89180 | Power Unit WEu               |
|     | 4203 035 89190 | Power Unit GB                |
| 2   | 4203 035 89200 | Twisted Wire Beaters in pair |
| 3   | 4203 035 89210 | Dough Hooks in pair          |