



Philips Consumer Lifestyle

Version: A

# Service Manual

### PRODUCT INFORMATION

- This product meets requirements regarding interference suppression on radio and TV.
- After the product has been repaired, it should function properly and has to meet the safety requirements as officially laid down at this moment.

### DISASSEMBLY – AND RE-ASSEMBLY ADVISE

- No specific issues

### REPAIR INSTRUCTION

- No specific issues

### OPTIONAL (accessories)

### General specifications:

- Non – slip feet
- Safety clamps
- Integrated cord storage
- speed setting: 1
- color: Ink black + white
- Dishwasher safe, all detachable parts

### Dimensions:

- Length : 240 mm
- Width : 218 mm
- Height : 395 mm (incl. pusher)
- Weight : 3,5 kg

### TECHNICAL INFORMATION:

#### - High Voltage Versions:

- Voltage : 220 V - 240 V
- Frequency : 50 Hz - 60Hz
- Type plate Wattage : 700 W

- Input Power : 700 W
- Speeds : 1 speed
- Pulp Container : Integrated – 1,2 l
- Juice Jug : 800 ml + 20 % margin  
(incl. foam separator)
- Sieve : upside down sieve
- Juice collector : Yes
- Juicer lid with feeding tube : 75 mm
- Lid fixation locking arm : Yes
- Pusher : Yes
- Spout : Yes, integrated in juice collector
- Drip Stop : No
- Cleaning brush : No
- Feet : Rubber inserts
- Cord storage : Yes (Manual around feet)
- Cord length: 1 m

<b>No load speed incl. sieve assy</b>	11000 rpm	± 10
---------------------------------------	-----------	------

## Used materials

HR1855/30

HR1855/31

Housing	: ABS
Bottom	: PP
Feet base	: PA 6.6
Feet insert	: EPDM rubber
Speed knob Base Knob	: ABS
Knob cover	: SAN
Tray body	: ABS
Pulp indication window	: SAN
Spout body	: POM
Spout tube	: Stainless steel
Spout accessory	: ABS
Juicer lid body	: SAN
Juicer ring safety ring	: ABS
Pusher	: ABS
Pulp container	: ABS
Sieve	: Stainless steel
Sieve coupling	: Polyphenylenoxid incl. 30 % Fibers (PPO GF30)
Juice jug	: SAN
Foam seperator	: ABS

Dishwasher friendly parts : Yes (all detachable parts)



Pos	Service code	Description
1	4203 036 01261	Pusher
2	4203 036 01271	Lid
3	4203 036 01281	Juice collector + spout
4	4203 036 00811	Pulp container
5	4203 036 00821	Filter
6	4203 036 01291	Juice jug + Lid

# Exploded view (repair)

HR1855/30

HR1855/31



Colour: white



New hinge

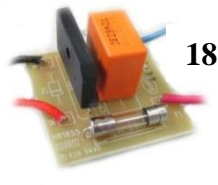
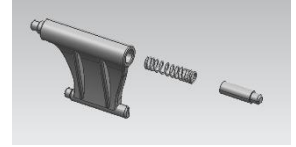

Pos	Service code	Description
7	4203 036 00841	driving shaft
8	4203 036 01301	Housing
9	4203 036 01311	Cap (1 pcs)
10	4203 036 01321	Bottom (incl. 4 feet)
11	4203 036 01331	Feet (1 pcs) not shown
12	4203 036 00891	spring for safety lever (not shown)
13	4203 036 00901	safety lever
14	4203 036 01341	On/Off knob
15	4203 036 10721	Clamp + hinge lever (1 pcs.)
16	4203 036 00931	Motor 220-240 V 50/60 Hz
	4203 036 01611	Motor (CN)
17	4203 036 00941	motor cushion
18	4203 036 00951	PCBA 220-240 V
19	4203 036 00961	Main switch holder
20	4203 036 00971	Main housing part
21	4203 036 00981	rotary switch
22	4203 036 00991	micro switch
23	4203 036 01361	Power cord Eu
	4203 036 01371	Power cord UK/DB/SG (3 pin)
	4203 036 01381	Power cord CN

## Circuit wire:

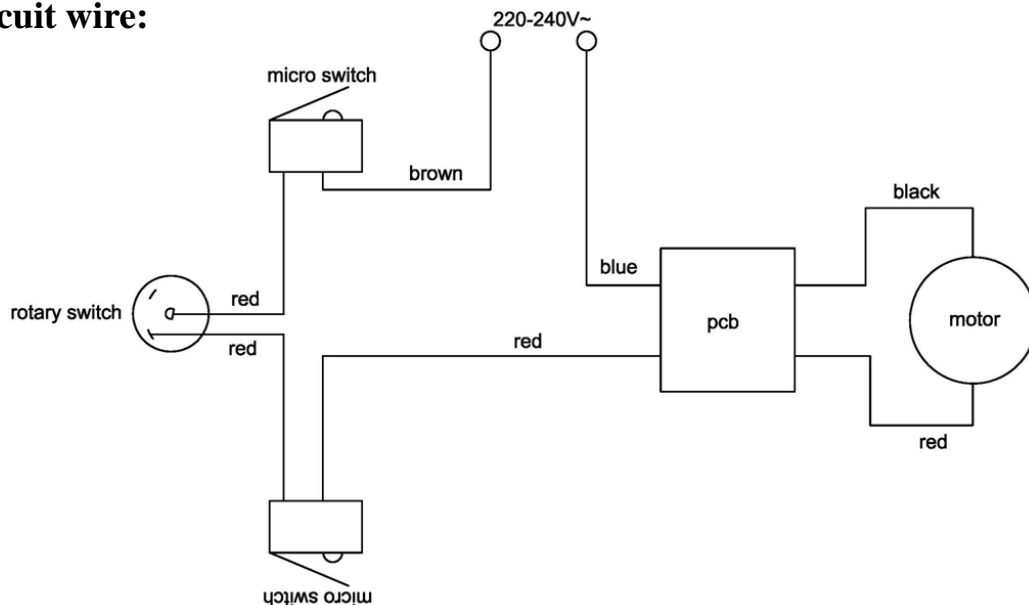

## 1) Remove the Bottom

Open all 4 screws (T15) to remove the Bottom.



## 2) Change the driving shaft

First you have to remove the bottom – see point 1

Turn the coupling to the left direction,

And hold the motorschaft on the back side with a screw driver



## 3) Change the motor

First you have to remove the driving shaft – see point 2

Then remove the 3 caps and the 3 screws on the top of housing.

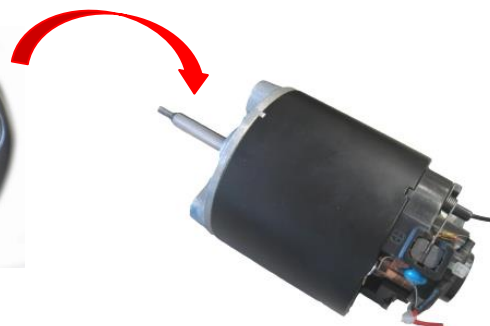
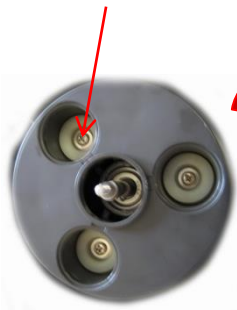

## 4) Remove the safety switch

Open the screw and remove the safety pin

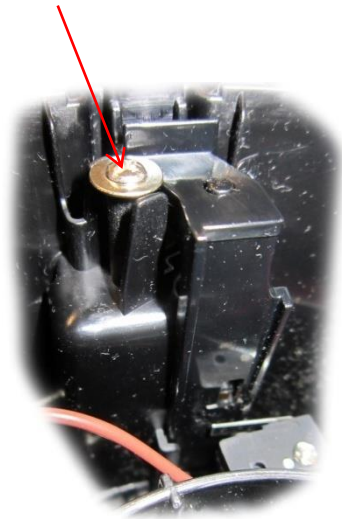

## 5) Remove the On/Off knob:

Pull the flaps and you can remove the knob

