



Philips Consumer Lifestyle

Version A

Service Manual

PRODUCT INFORMATION

General:

HR1871: Juicer - easy to clean easy to use

Safety information

- This product meets the requirements regarding interference suppression on radio and TV.
- After the product has been repaired, it should function properly and has to meet the safety requirements as officially laid down at this moment.

DISASSEMBLY- AND RE-ASSEMBLY ADVICE

- No specific issues

OPTIONAL (accessories)

- No specific issues

TECHNICAL INFORMATION

- High Voltage Versions:

Voltage	: 220 V - 240 V
Frequency	: 50 Hz - 60Hz
Type plate Wattage	: 800 W (HR1871) 1000 W (HR1873/00)

- Low Voltage Versions:

Voltage	: 110 V - 127 V
Frequency	: 50 Hz - 60 Hz
Type Plate Wattage	: 800 W

- Input Power	: 800 W
- Speeds	: 2 speeds (1: 7500 - 2: 10000 rpm)
- Pulp Container	: Integrated
- Juice Jug (incl. foam separator)	: 1250 ml + 20 % margin
- Sieve	: Stainless steel
- Juice collector	: Yes
- Juicer lid with feeding tube	: 81 mm
- Lid fixation locking arm	: Yes
- Pusher	: Yes
- Spout	: Yes
- Drip Stop	: Yes (detachable)
- Cleaning brush	: No
- Feet	: Rubber inserts
- Cord storage	: Yes (Manual around feet)
- Housing materials	: Stainless steel metal wrap
- Dishwasher friendly parts	: Yes (all detachable parts)

TECHNICAL INFORMATION

HRI871/00 /05 / HRI873/00

Dimensions:

- Length : 270 mm
- Width : 245 mm
- Height : 430 mm (incl. pusher)
- Weight : 4320 g

Used materials:

- Housing : ABS
- Bottom : PP
- Feet base : PA 6.6
- Feet insert : EPDM rubber
- Speed knob Base Knob : ABS
Knob cover : SAN
- Tray body : ABS
- Pulp indication window : SAN
- Spout body : POM
- Spout tube : Stainless steel
- Spout accessory : ABS
- Juicer lid body : SAN
- Juicer ring safety ring : ABS
- Pusher : ABS
- Pulp container : ABS
- Sieve : Stainless steel
- Sieve coupling : Polyphenylenoxid
incl. 30 % Fibers (PPO GF30)
- Juice jug : SAN
- Foam separator : ABS

PARTS LIST

Pos	Service code	Description
1	4203 035 96721	Pusher
2	4203 035 96731	Lid
3	4203 035 96741	Juice collector
4	4203 035 96751	Integrated pulp container
5	4203 035 96761	Spout accessory
6	4203 035 96771	Detachable spout
7	4203 035 96781	Filter
8	4203 035 96791	Juice jug + Lid
9	4203 035 96801	Driving shaft
10	4203 035 96811	Main housing with metal wrap + Motor crussion and Stopper
11	4203 035 96821	Rubber ring
12	4203 035 96831	Bottom incl. Current limiter
13	4203 035 96841	Anti slip ring
14	4203 035 96851	On/Off knob
15	4203 035 96861	On/Off switch electronic
16	4203 035 96871	Safety switch
17	4203 035 96881	Brack Switch support assembly
18	4203 035 96891	Plastic holder for On/Off switch
19	4203 035 96901	Locking arm
20	4203 035 96911	Locking arm stopper right
21	4203 035 96921	Locking arm stopper left
22	4203 035 96931	PCBA 220 - 240 V
23	4203 035 96941	Motor 220 - 240 V
24	4203 035 96951	Power cord WEu
	4203 035 96961	Power cord CN
	4203 035 96971	Power cord TW
	4203 035 96981	Power cord UK
	4203 035 99611	Power cord AUS

 = changed

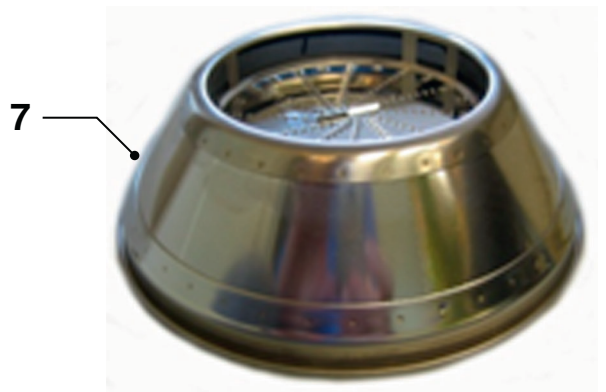

3D VIEW FOR REPAIR

HRI871/00 /05 / HRI873/00

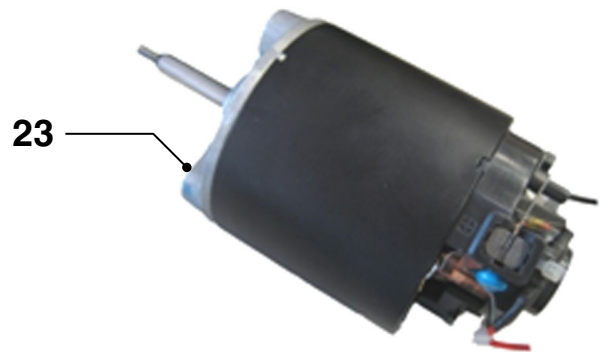
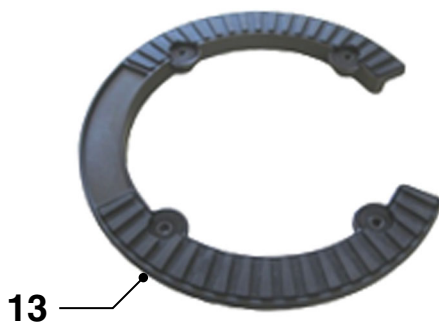
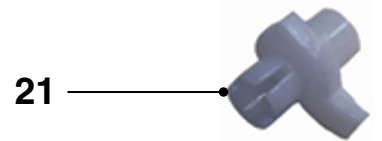
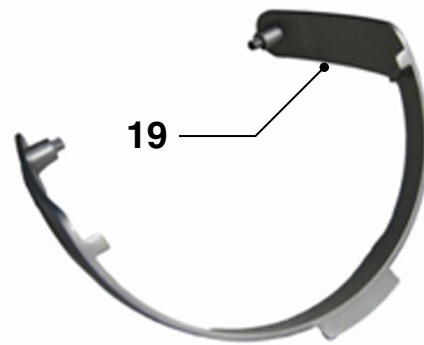
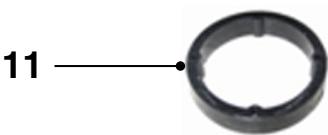
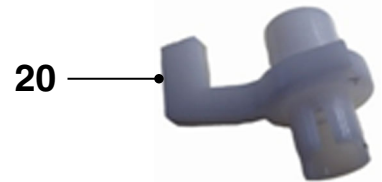
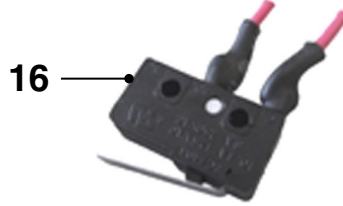
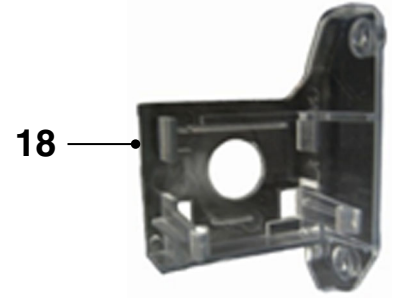
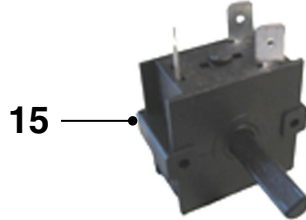
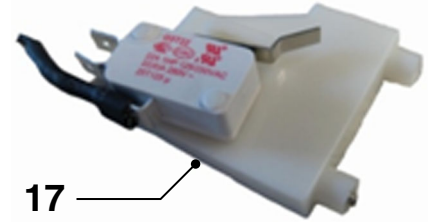
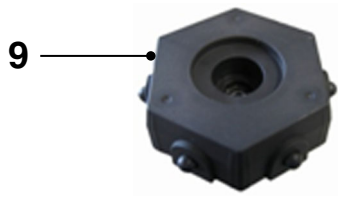

REPAIR INSTRUCTION

HRI871/00 /05 / HRI873/00

1. Remove the Bottom

First you have to remove the anti slip ring.

Open all 4 screws (T15) to remove the Bottom.



2. Change the driving shaft

First you have to remove the bottom (see point 1.)

Remove the cap, use a small screw driver.

Turn both screws to the left direction, and hold the motorshaft on the back side.



3. Change the motor

First you have to remove the driving shaft (see point 2.)

Then remove the 3 caps and the 3 screws on the top of housing.

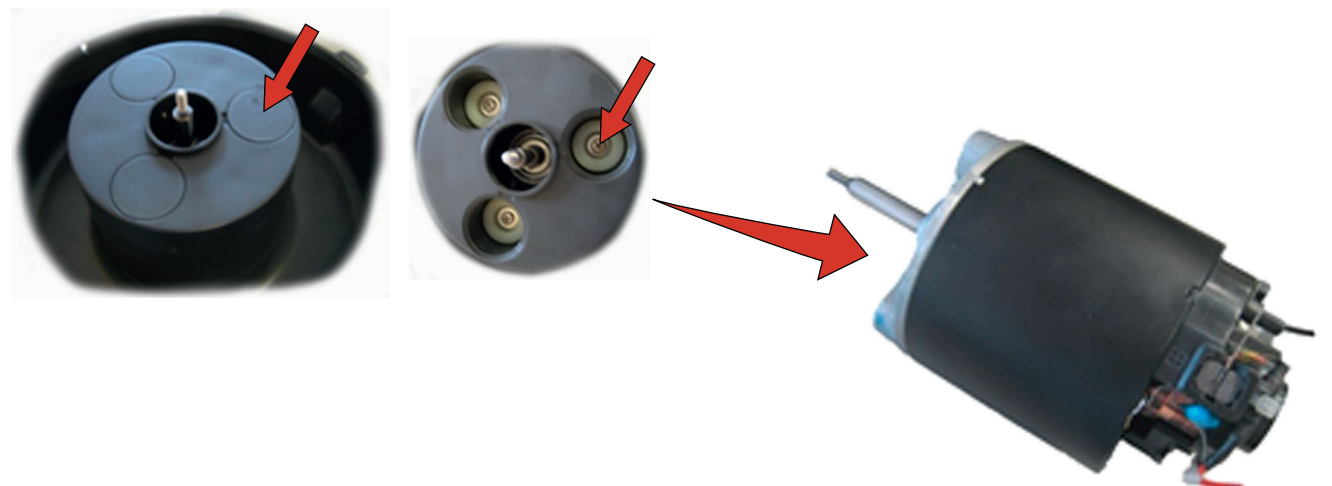

REPAIR INSTRUCTION

HRI871/00 /05 / HRI873/00

4. Remove the safety switch

When you open both flaps you can remove the safety switch.

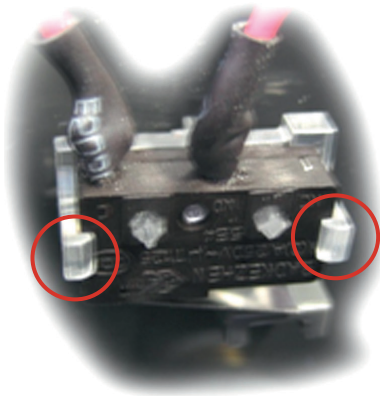

5. Remove the locking arm

Remove on each side the springs.

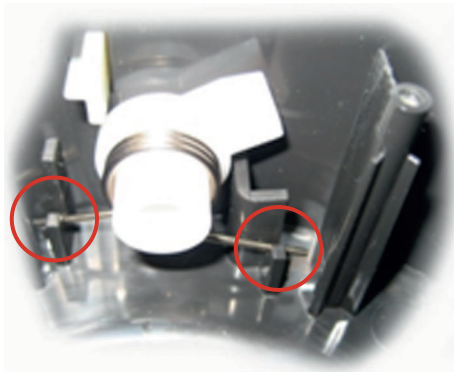

Open the screw on both sides.



Circuit diagram High Voltage Version (without brake)

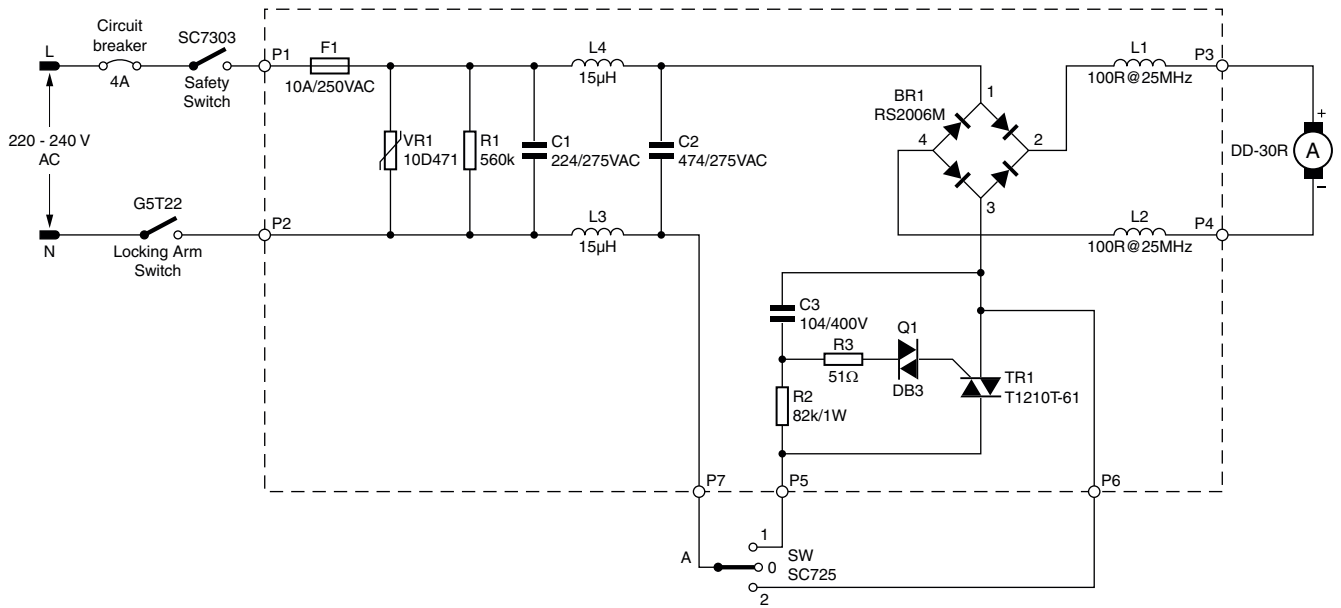

Circuit diagram Low Voltage Version (without brake)

