

Sonicare toothbrush

Service
Service
Service



HX6160, Sanitizer

HX6921, FlexCare+ (low end)

HX6942, FlexCare+ Pro Trial

HX6950, (handle, FlexCare+)

HX6972, FlexCare+ Retail with Sanitizer

HX6992, FlexCare+ ProDispense with Sanitizer

HX6993, FlexCare+ProDispense

Philips Consumer Lifestyle

Service Manual

SERVICE POLICY

Product will be serviced for 3 years after End of Life.

PRODUCT INFORMATION

Easy-start

This Sonicare model comes with the Easy-start feature activated.

The Easy-start feature gently increases power over the first 14 brushings to ease into the Sonicare experience..

Easy-start can also be switched off.

To deactivate Easy-start:

Press and hold the power on/off button for 2 seconds. You hear 1 beep to indicate that the Easy-start feature has been deactivated.

To activate Easy-start:

Press and hold the power on/off button for 2 seconds. You hear 2 beeps to indicate that the Easy-start feature has been activated.

Smartimer

The Smartimer indicates that your brushing cycle is complete when it automatically turns off the toothbrush at the end of the brushing cycle. Dental professionals recommend brushing at least 2 minutes twice a day.

Quadpacer

The Quadpacer feature ensures that you brush all four sections of your mouth evenly and thoroughly. You will hear a short beep and notice a brief pause in brushing action. This is the signal to move to the next section of your mouth. The Quadpacer feature on this model has been activated. To deactivate or reactivate the Quadpacer features:

Place the handle with a brush head attached on the plugged-in charger. Press and hold the mode button for 2 seconds.

You hear 1 beep to indicate the Quadpacer has been deactivated or you hear 2 beeps to indicate the Quadpacer has been activated.

Charging Your Sonicare Note: It takes at least 24 hours to fully charge the battery.

Plug the charger into a live electrical outlet and place the handle on the charger. The battery indicator light located in the power on/off button flashes to indicate that the toothbrush is charging. When the Sonicare is fully charge, the battery charge indicator light will stop flashing

Battery Charge Indicator

When the handle is placed in the charger, the flashing light of the battery gauge indicates that the toothbrush is charging.

Indicates amount of charge left in battery

3 green LEDs: fully charged

2 green LEDs: 67-94%

1 green LED: 34-66%

1 flashing yellow LED: less than 25%

If the battery charge of your Sonicare is low, you will hear 3 beeps at the end of the brushing cycle and the charge indicator LED flashes yellow for 30 seconds.

Brushing modes

The programmable brushing allow you to customize the brushing action. There are five different brushing modes.

Clean: Complete whole mouth cleaning (2 minutes).

Gum Care: Complete whole mouth cleaning (2 minutes) plus gentle cleaning for problem areas and along the gumline (1 minute).

Refresh: Touch-up for a quick clean (1 minute).

Sensitive: Gentle cleaning for sensitive gums and teeth (2 minutes).

Massage: Gentle gum stimulation (2 minutes).

Reminder bristles

Reminder bristles are introduced to remind the consumer to replace their BHs at the recommended replacement time.

The color of the reminder bristles wears out as you use the brush head and starts fading from the tip downward. When the reminder bristles have faded half way it is time to replace the brush head after approximately 3 months of use.

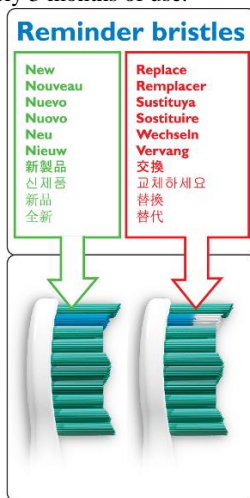

Cleaning

Do not place brush head, the handle or the charger in the dishwasher. Rinse the brush head and bristles after each use and allow to air dry completely. Remove the brush head at least once a week and clean the connection between the brush head and the handle and allow to air dry completely. Do not use sharp objects to press on the rubber seal at the top of the handle as this may cause damage. Clean the rest of the handle periodically with mild soap and a moist cloth. **Unplug the charger before cleaning and use a moist cloth to wipe the surface of the charger.** If your toothpaste contains peroxide, baking soda or other bicarbonate (common in whitening toothpastes), thoroughly clean the brush head and the handle with soap and water after each use. Otherwise the plastic may crack

SAFETY INFORMATION

- Consult your physician prior to using Sonicare if you have medical concerns.
- Consult your dental professional before you use this product if You have had oral or gum surgery in the previous 2 months.
- Sonicare has been tested and is compliant with safety standards for electromagnetic devices.
- Contact your dental professional if excessive bleeding occurs after using this product or bleeding continues to occur after 1 week of use.
- Do not place or store the charger or sanitizer where it can fall or be pulled into a bathtub, sink or toilet.
- Discontinue use of the sanitizer if the UV light bulb remains on when the door is open. UV light can be harmful to the human eye and skin. This device should be kept out of reach of children at all times.
- The UV light bulb is hot during and immediately after the sanitizing cycle. Do not touch the UV light when it is hot.
- Do not operate the UV sanitizer where aerosol (spray) products Are being used or where oxygen is being administered.
- DO NOT plug the charger into an outlet with incorrect voltage.

**TECHNICAL INFORMATION
Toothbrush Handle**

- Voltage : 4.05 Volts d.c. at full charge
- Power consumption : 2 watts
- Charging time : Empty-to-full: 24 hours @ 110V
- Operating time : Full-to-empty: 84 minutes
- Battery type : Lithium Ion

Travel Charger

- Voltage / Frequency : 100-240V, 50 - 60 Hz
- Power consumption : 0.4 watts @ 100V / 1.4 watts @ 240V

UV Sanitizer / Charger

- Voltage / Frequency : 100-240, 50 - 60 Hz
- Power consumption : 0.9 watts @ 100V / 1.3 watts @ 240V (Charge Mode Only)
5.7 watts @ 100V / 6.1 watts @

240V (UV and Charge Mode)

REPAIR INSTRUCTION

- Brush head (pos 2) In case of a defective brush head, the complete brush head must be replaced.
- Charging unit (pos 1) In case of a defective charging unit or cordset, the complete charging unit must be replaced.
- Handle toothbrush (not available in service channel) The batteries inside cannot be replaced. In case of a defect, the complete unit must be replaced.
- Charging the handle. The handle should be charged for at least 24 hours during the first few days of use.
- Sanitizer(pos 3) In case of a defective sanitizer, the complete sanitizer unit must be replaced.
- Sanitizer UV light bulb Replacement(pos 4)

Environment

- The rechargeable battery inside your Sonicare cannot be replaced, but is easy to remove for recycling. Refer to the instructions below for battery removal.
- Do not throw away the appliance or the UV light bulb(bulb contains mercury) with the normal household waste at the end of it's life, but hand it in at an official collection point for proper disposal.
- If you have any recycling questions, contact your local waste management office.

1. To deplete the rechargeable battery of any charge, remove the handle from the charger, turn on the Sonicare and let it run until it stops. Repeat this step until you can no longer switch on the Sonicare.

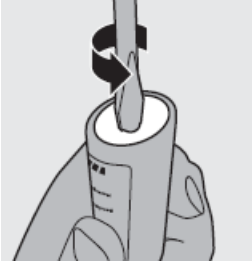

2. Insert a screwdriver into the slot located at the bottom of the handle and turn counterclockwise to release the bottom cap.

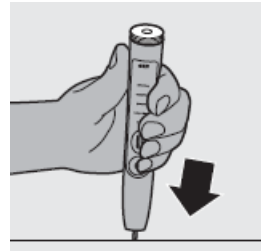

3. Hold the handle upside down and push down on the shaft to release the internal components of the handle.

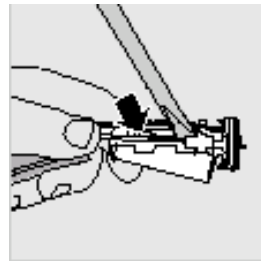

4. Insert the screwdriver under the circuit board, next to the battery connections, and twist to break the connections. Remove the circuit board and pry the battery from the plastic carrier.

5. The rechargeable battery can now be recycled and the rest of the product discarded appropriately.

SANITIZER

With the UV sanitizer you can clean your brush head after every use. After brushing, rinse the brush head and shake off excess water. Place your finger in the door recess on top of the sanitizer and pull open the door. Place the brush head on one of the two pegs in the sanitizer so that the bristles are directly facing the light bulb. Close the door and press the green power on/off button once to start the UV clean cycle. It runs for 10 minutes then automatically shuts off. The sanitizer is in operation when the blue light glows through the window and the UV clean LED flashes slowly.

Note: The sanitizer stops if the door is opened during operation.

DISASSEMBLY- AND RE-ASSEMBLY ADVISE

- UV light bulb replacement

1. Unplug the sanitizer.
2. Pull the drip tray straight out.
3. To remove the screen, grasp the edges next to the snaps, gently squeeze and pull out the protective screen..

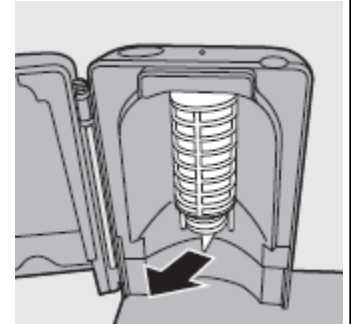

4. Remove light bulb by grasping it and pulling it out of the metal clasp.
5. Align the bottom of the replacement light bulb with metal clasp and push bulb into clasp then reinsert light bulb screen and drip tray.

**HX6160, HX6921, HX6942, HX6950, HX6972,
HX6992, HX6993**

SERVICE MANUAL - NITRO/ FLEXCARE+			
FlexCare+ , (HX6921, HX6942, HX6972, HX6992, HX6993)			
Pos	Service Code	Description	Comments
1	4235 010 06902	TRAVEL CHARGER - US, CANADA	Available as a Service part. Warranty claims should be routed to Call Centers.
	4235 010 06913	TRAVEL CHARGER - EURO, UAE, SOUTH AFRICA	
	4235 010 07103	TRAVEL CHARGER – UK	
	4235 090 02571	TRAVEL CHARGER – HONG KONG, UK, SINGAPORE, PHILIPPINES, MALAYSIA	
	4235 090 02541	TRAVEL CHARGER - JAPAN KOIZUMI	
	4235 090 02591	TRAVEL CHARGER - JAPAN YOSHIDA	
	4235 090 02551	TRAVEL CHARGER - KOREA	
	4235 090 02561	TRAVEL CHARGER - TAIWAN	
	4235 090 02531	TRAVEL CHARGER - CHINA	
	4235 090 02581	TRAVEL CHARGER - AUSTRALIA	
	4235 090 00971	TRAVEL CHARGER - RUSSIA	FC+ not released in Russia
2	8816 011 60540	PRO RESULTS BRUSH HEAD, REMINDER BRISTLES - US	Available as a Service part. Warranty claims should be routed to Call Centers.
	8816 011 21520	PRO RESULTS BRUSH HEAD, REMINDER BRISTLES - CANADA	
	8816 011 05030	PRO RESULTS BRUSH HEAD, REMINDER BRISTLES - EURO, UAE, SOUTH AFRICA, UK, RUSSIA	
	8816 011 05550	PRO RESULTS BRUSH HEAD, REMINDER BRISTLES - HONG KONG, SINGAPORE, PHILIPPINES, MALAYSIA	
	8816 012 05460	PRO RESULTS BRUSH HEAD, REMINDER BRISTLES - KOIZUMI	
	8816 012 05460	PRO RESULTS BRUSH HEAD, REMINDER BRISTLES - YOSHIDA	
	8816 011 05570	PRO RESULTS BRUSH HEAD, REMINDER BRISTLES - KOREA	
	8817 001 05860	PRO RESULTS BRUSH HEAD, REMINDER BRISTLES - TAIWAN	
	8817 01 05810	PRO RESULTS BRUSH HEAD, REMINDER BRISTLES - CHINA	
	8816 013 05340	PRO RESULTS BRUSH HEAD, REMINDER BRISTLES - AUSTRALIA	
2	8816 021 62540	MINI PRO RESULTS BRUSH HEAD, REMINDER BRISTLES - US	Available as a Service part. Warranty claims should be routed to Call Centers.
	8816 021 21530	MINI PRO RESULTS BRUSH HEAD, REMINDER BRISTLES - CANADA	
	8816 021 05030	MINI PRO RESULTS BRUSH HEAD, REMINDER BRISTLES - EURO, UAE, SOUTH AFRICA, UK, RUSSIA	
	8816 012 05550	MINI PRO RESULTS BRUSH HEAD, REMINDER BRISTLES - HONG KONG, SINGAPORE, PHILIPPINES, MALAYSIA	
	TBD	MINI PRO RESULTS BRUSH HEAD, REMINDER BRISTLES - YOSHIDA & KOIZUMI	
	8816 021 05570	MINI PRO RESULTS BRUSH HEAD, REMINDER BRISTLES - KOREA	
	8816 021 05860	MINI PRO RESULTS BRUSH HEAD, REMINDER BRISTLES - TAIWAN	
	8816 021 05570	MINI PRO RESULTS BRUSH HEAD, REMINDER BRISTLES - CHINA	
	TBD	MINI PRO RESULTS BRUSH HEAD, REMINDER BRISTLES - AUSTRALIA	

**HX6160, HX6921, HX6942, HX6950, HX6972,
HX6992, HX6993**

3	4235 010 09722	UV SANITIZER - US, CANADA	Available as a Service part. Warranty claims should be routed to Call Centers.
	4235 010 09732	UV SANITIZER - EURO, UAE, SOUTH AFRICA	
	4235 010 09742	UV SANITIZER - UK	
	4235 090 02671	UV SANITIZER - HONG KONG, SINGAPORE, PHILIPPINES, MALAYSIA	
	4235 090 02641	UV SANITIZER - JAPAN KOIZUMI	
	N/A	UV SANITIZER - JAPAN YOSHIDA	
	4235 090 02651	UV SANITIZER - KOREA	
	4235 090 02661	UV SANITIZER - TAIWAN	
	4235 090 02631	UV SANITIZER - CHINA	
	4235 090 02701	UV SANITIZER - AUSTRALIA	
	N/A	UV SANITIZER - RUSSIA	
4	4235 090 01561	UV SANITIZER BULB - ALL REGIONS	Available as a Service part. Warranty claims should be routed to Call Centers.
5	4235 090 01571	UV SANITIZER BULB GUARD - ALL REGIONS	
6	4235 090 01581	UV SANITIZER DRIP TRAY - ALL REGIONS	
7	4235 010 06921	CHARGER COVER AND BASE	
8	4235 020 20971	TRAVEL CASE	Available as a Service part. Warranty claims should be routed to Call Centers.
9	4235 010 07152	DELUX CHARGER (TRAVEL CHARGER WITH DECO) - US, CANADA	
	4235 010 07163	DELUX CHARGER (TRAVEL CHARGER WITH DECO) - EURO, UAE, SOUTH AFRICA	
	4235 010 07173	DELUX CHARGER (TRAVEL CHARGER WITH DECO) - UK	
	4235 090 02491	DELUX CHARGER (TRAVEL CHARGER WITH DECO) - HONG KONG, UK, SINGAPORE, PHILIPPINES, MALAYSIA	
	4235 090 02461	DELUX CHARGER (TRAVEL CHARGER WITH DECO) - JAPAN KOIZUMI	
	4235 090 02511	DELUX CHARGER (TRAVEL CHARGER WITH DECO) - JAPAN YOSHIDA	
	4235 090 02471	DELUX CHARGER (TRAVEL CHARGER WITH DECO) - KOREA	
	4235 090 02481	DELUX CHARGER (TRAVEL CHARGER WITH DECO) - TAIWAN	
	4235 090 02451	DELUX CHARGER (TRAVEL CHARGER WITH DECO) - CHINA	
	4235 090 02501	DELUX CHARGER (TRAVEL CHARGER WITH DECO) - AUSTRALIA	
N/A	DELUX CHARGER (TRAVEL CHARGER WITH DECO) - RUSSIA		
10	4235 090 02081	HANDLE +BH - US, CANADA	Not available as a Service Part. Only available as warranty. Handle warranty claims must be routed to Call Centers for replacement.
	4235 090 02941	HANDLE +BH - EURO, UK, UAE, SOUTH AFRICA	
	4235 090 02221	HANDLE +BH - CHINA	
	4235 090 02211	HANDLE +BH - REST OF ASIA	

PARTS LIST AND EXPLODED VIEW, Cont'

